

Integrated Controller™ User Manual



Contents

Preface	3
Terms of use	4
IC Basic.....	5
Connection diagram	5
Applicable for: LA14 and LA25.....	5
Applicable for: LA33, LA36 and LA37.....	6
I/O specifications.....	7
Applicable for: All.....	7
IC Advanced	8
Connection diagram	8
Applicable for: LA14 and LA25.....	8
Applicable for: LA33, LA36 and LA37.....	9
I/O specifications.....	10
Applicable for: All actuators	10
Correct Wiring of Power GND and Signal GND for IC Advanced.....	12
IC Parallel.....	13
Connection diagram	13
Applicable for: LA14 and LA25.....	13
Applicable for: LA33, LA36 and LA37.....	14
I/O specifications.....	15
Applicable for: All actuators	15
The parallel system.....	16
Applicable for: All actuators.....	16
System Monitoring for Parallel	18
Alignment of the parallel actuator system.....	19
Position Lost and initialization	20
Recovery Run mode	20
IC - Parallel manual service mode	21
Standard run.....	22
Virtual limits	22
Endstop reached signal	23
Active low	23
Hysteresis for Endstop reached signal	23
Soft start and soft stop	23
Speed.....	24
Current cut-off	24
Contacts.....	25

Preface

Dear User,

We are delighted that you have chosen a LINAK® product.

LINAK systems are high-tech products based on many years of experience in the manufacture and development of actuators, lifting columns, desk frames, electric control boxes, controls, batteries, accessories and chargers.

This User Manual does not address the end user. It is intended as a source of information for the equipment or system manufacturer only, and it will tell you how to install, use and maintain your LINAK electronics. The manufacturer of the end product has the responsibility to provide a User Manual, where relevant safety information from this manual is passed on to the end user.

We are convinced that your LINAK product/system will give you many years of problem-free operation.

Before our products leave the factory, they undergo both function and quality testing. Should you, nevertheless, experience problems with your product/system, you are always welcome to contact your supplier.

LINAK subsidiaries and some distributors situated all over the world have authorised service centres, which are always ready to help you. Locate your local contact information on the back page.

LINAK provides a warranty on all products. (See warranty section).

This warranty, however, is subject to correct use in accordance with the specifications, maintenance being done correctly, and any repairs being carried out at a service centre, which is authorised to repair LINAK products.

Changes in installation and use of LINAK systems can affect their operation and durability. The products may only be opened by authorised personnel.

This User Manual has been written based on the present technical knowledge. LINAK reserves the right to carry out technical modifications and keeps the associated information updated.

LINAK A/S

Terms of use

LINAK® takes great care in providing accurate and up-to-date information on its products. However, the user is responsible for determining the suitability of LINAK products for a specific application.

Due to continual development, LINAK products are subject to frequent modifications and changes. LINAK reserves the rights to conduct modifications, updates, and changes without any prior notice. For the same reason, LINAK cannot guarantee the correctness and actual status of imprinted information on its products.

LINAK uses its best efforts to fulfil orders. However, for the reasons mentioned above, LINAK cannot guarantee availability of any particular product at any given time. LINAK reserves the right to discontinue the sale of any product displayed on its website or listed in its catalogues or in other written material created and produced by LINAK, LINAK subsidiaries, or LINAK affiliates.

All sales are subject to the 'Standard Terms of Sale and Delivery for LINAK A/S' available on LINAK websites.

LINAK and the LINAK logotype are registered trademarks of LINAK A/S. All rights reserved.

IC Basic

Connection diagram

Applicable for: LA14 and LA25

Power		
BROWN	12/24 V DC	2
BLUE	GND	1
Control		
RED	Extends the actuator	4
BLACK	Retracts the actuator	3
Feedback		
YELLOW	Endstop reached in	5
GREEN	Endstop reached out	6

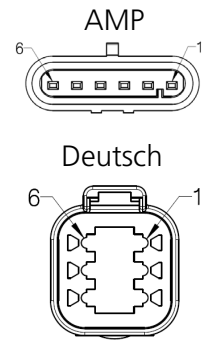

Please be aware that if the power supply is not properly connected, you might damage the actuator!

IC Basic

Connection diagram

Applicable for: LA33, LA36 and LA37

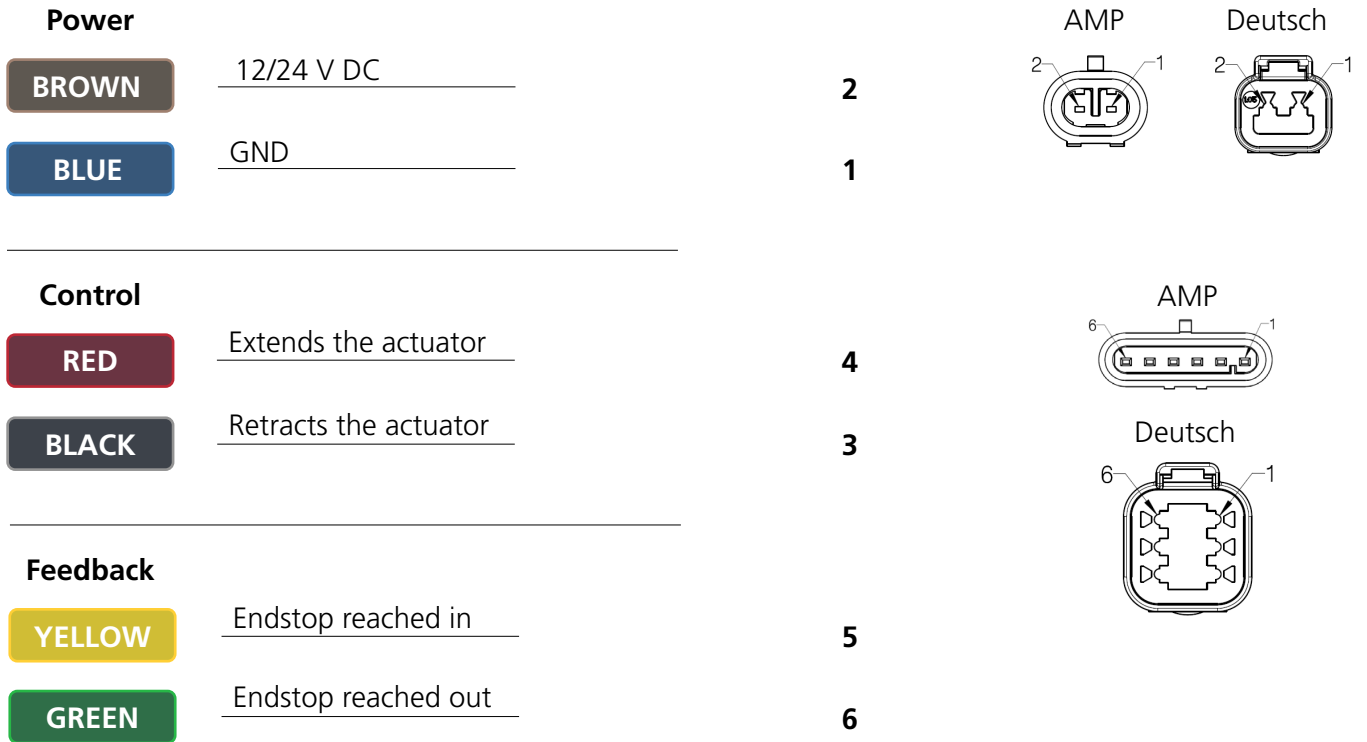

Please be aware that if the power supply is not properly connected, you might damage the actuator!

IC Basic

I/O specifications

Applicable for: All

Input/Output	Specification	Comments
Description	Easy to use interface with integrated power electronics (H-bridge). Actuators with "IC option" cannot be operated with PWM power supply.	
Brown	12 V DC \pm 20 % 24 V DC \pm 10 % Connect Brown to positive	Note: Do not change the power supply polarity on the Brown and Blue wires! Power supply GND (-) is electrically connected to the housing
Blue	12/24 V DC - (GND) Connect Blue to negative	
Red	Extends the actuator	The signal becomes active at: > 67% of V_{IN} The signal becomes inactive at: < 33% of V_{IN} Input current: 10 mA
Black	Retracts the actuator	
Yellow	Endstop reached in	Output voltage min. $V_{IN} - 2$ V Source current max. 100 mA Endstop reached signals are NOT potential free. Endstop reached signals can be configured with BusLink software according to any position needed When configuring virtual endstop, it is not necessary to choose the position feedback Endstop reached signal and virtual endstop will work even when feedback is not chosen.
Green	Endstop reached out	
Violet	Not to be connected	
White	Not to be connected	

IC Advanced

Connection diagram

Applicable for: LA14 and LA25

Power		Deutsch
BROWN	12/24 V DC	
BLUE	GND	1
<hr/>		
Control		
RED	Extends the actuator	4
BLACK	Retracts the actuator	3
<hr/>		
Feedback		
VIOLET	Analogue OR Digital position feedback	6
WHITE	Signal GND	5
<hr/>		
YELLOW	Endstop reached in	7
GREEN	Endstop reached out	8

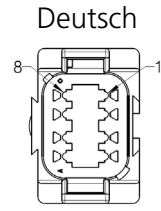

Please be aware that if the power supply is not properly connected, you might damage the actuator!



Configuration of IC Advanced is possible with the BusLink software for PC. The newest version is available online [here](#).

Please note: The BusLink configuration cable must be purchased separately. Item number for BusLink cable kit: 0147999 (adapter + USB2Lin)

IC Advanced

Connection diagram

Applicable for: LA33, LA36 and LA37

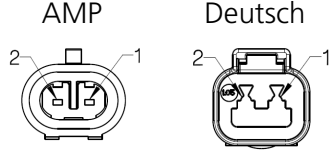
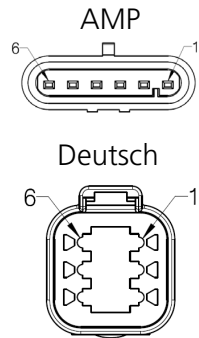
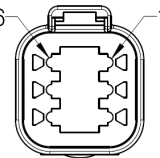
Power			
BROWN	12/24 V DC	2	
BLUE	GND	1	
Control			
RED	Extends the actuator	2	
BLACK	Retracts the actuator	1	
Feedback			
VIOLET	Analogue OR Digital position feedback	4	
WHITE	Signal GND	3	
YELLOW	Endstop reached in	5	
GREEN	Endstop reached out	6	



Please be aware that if the power supply is not properly connected, you might damage the actuator!



Configuration of IC Advanced is possible with the BusLink software for PC.
The newest version is available online [here](#).

Please note: The BusLink configuration cable must be purchased separately.
Item number for BusLink cable kit: 0367999 (adapter + USB2Lin)

IC Advanced

I/O specifications

Applicable for: All actuators

Input/Output	Specification	Comments
Description	<p>Easy to use interface with integrated power electronics (H-bridge).</p> <p>The actuator is also equipped with an electronic circuit that gives an absolute or relative feedback signal.</p> <p>Actuators with "IC option" cannot be operated with PWM power supply.</p> <p>The actuator can be configured with BusLink.</p>	
Brown	<p>12 V DC \pm 20 %</p> <p>24 V DC \pm 10 %</p> <p>Connect Brown to positive</p>	<p>Note:</p> <p>Do not change the power supply polarity on the Brown and Blue wires!</p> <p>Power supply GND (-) is electrically connected to the housing</p>
Blue	<p>12/24 V DC - (GND)</p> <p>Connect Blue to negative</p>	
Red	Extends the actuator	<p>The signal becomes active at: $> 67\%$ of V_{IN} = ON</p> <p>The signal becomes inactive at: $< 33\%$ of V_{IN} = OFF</p> <p>Input current: 10 mA</p>
Black	Retracts the actuator	
Yellow	Endstop reached in	<p>Output voltage min. $V_{IN} - 2$ V</p> <p>Source current max. 100 mA</p> <p>Endstop reached signals are NOT potential free.</p> <p>Endstop reached signals can be configured with BusLink software according to any position needed.</p> <p>When configuring virtual endstop, it is not necessary to choose the position feedback.</p> <p>Endstop reached signal and virtual endstop will work even when feedback is not chosen.</p>
Green	Endstop reached out	

IC Advanced

I/O specifications

Applicable for: All actuators

Input/Output	Specification	Comments
Violet	Analogue feedback (0-10 V): Configure any high/low combination between 0-10 V	Ripple max. 200 mV Transaction delay 20 ms Linear feedback 0.5 % Max. current output. 1 mA
	Single Hall output (PNP)	Output voltage min. $V_{IN} - 2 V$ Max. current output: 12 mA Max. 680 nF For LA14 and LA25: Frequency is 20-30 Hz on Single Hall output depending on load. For LA33, LA36 and LA37: Frequency is 14-26 Hz on Single Hall output depending on load. Variation in power supply and load causes a variation in frequency and pulse length.
	Digital output feedback PWM: Configure any max./min. range between 0-100%	Output voltage min. $V_{IN} - 2 V$ Frequency: 75 Hz \pm 10 Hz as standard, but this can be customised. Duty cycle: Any low/high combination between 0 and 100 percent. Open collector source current max. 12 mA
	Analogue feedback (4-20 mA) Configure any max./min. range between 4-20 mA	Tolerances +/- 0.2 mA Transaction delay 20 ms Linear feedback 0.5 % Output: Source Serial resistance: 12 V: max. 300 ohm 24 V: max. 900 ohm
	All absolute value feedbacks (0-10 V, PWM and 4-20 mA)	Standby power consumption: 12 V: 60 mA 24 V: 45 mA The actuator should be made to activate its limit switches on a regular basis to ensure more precise positioning.
White	Signal GND	For correct wiring of Power GND and Signal GND - please see figure below

Correct Wiring of Power GND and Signal GND for IC Advanced

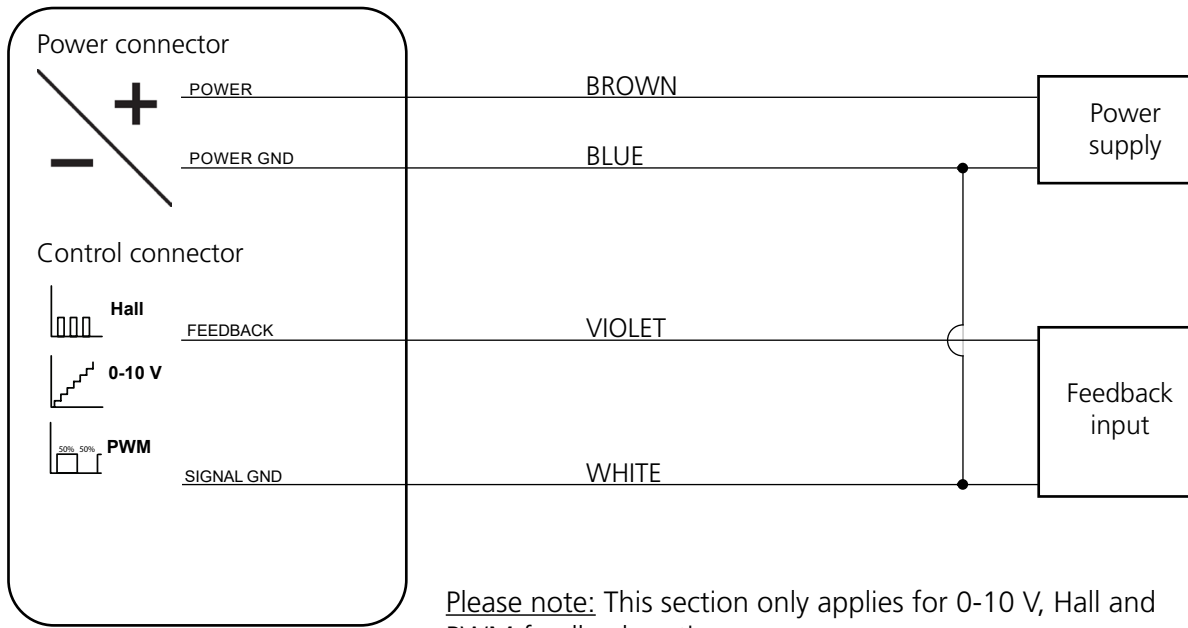

Please note: This section only applies for 0-10 V, Hall and PWM feedback options.

The following connection illustration applies to 4-20 mA only:

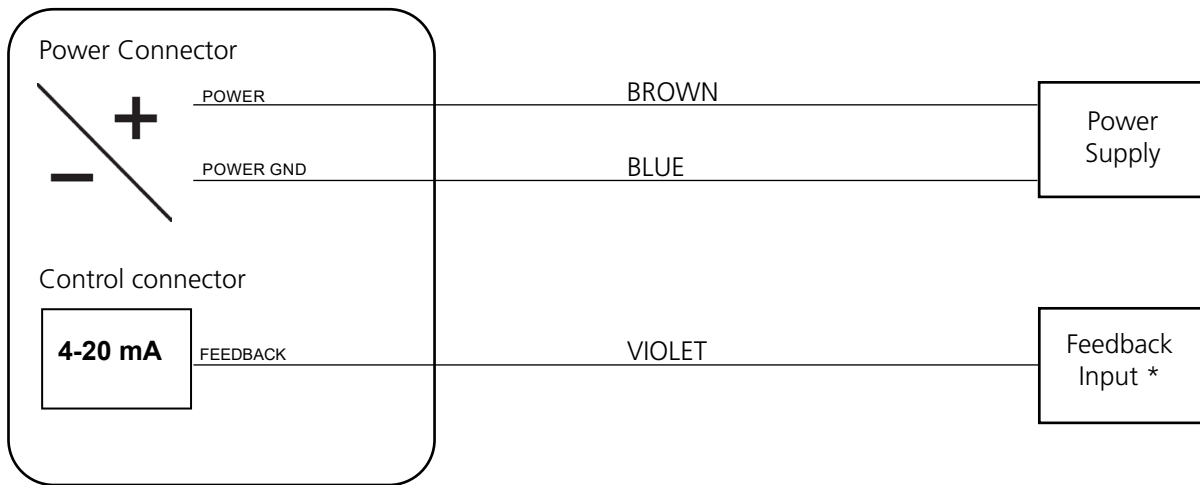

*Only to be used on differential input card. Do not use single ended input card.
Do NOT connect or put the White wire anywhere near GND, as this will create ground loops, disturbing the mA-signal.

IC Parallel

Connection diagram

Applicable for: LA14 and LA25

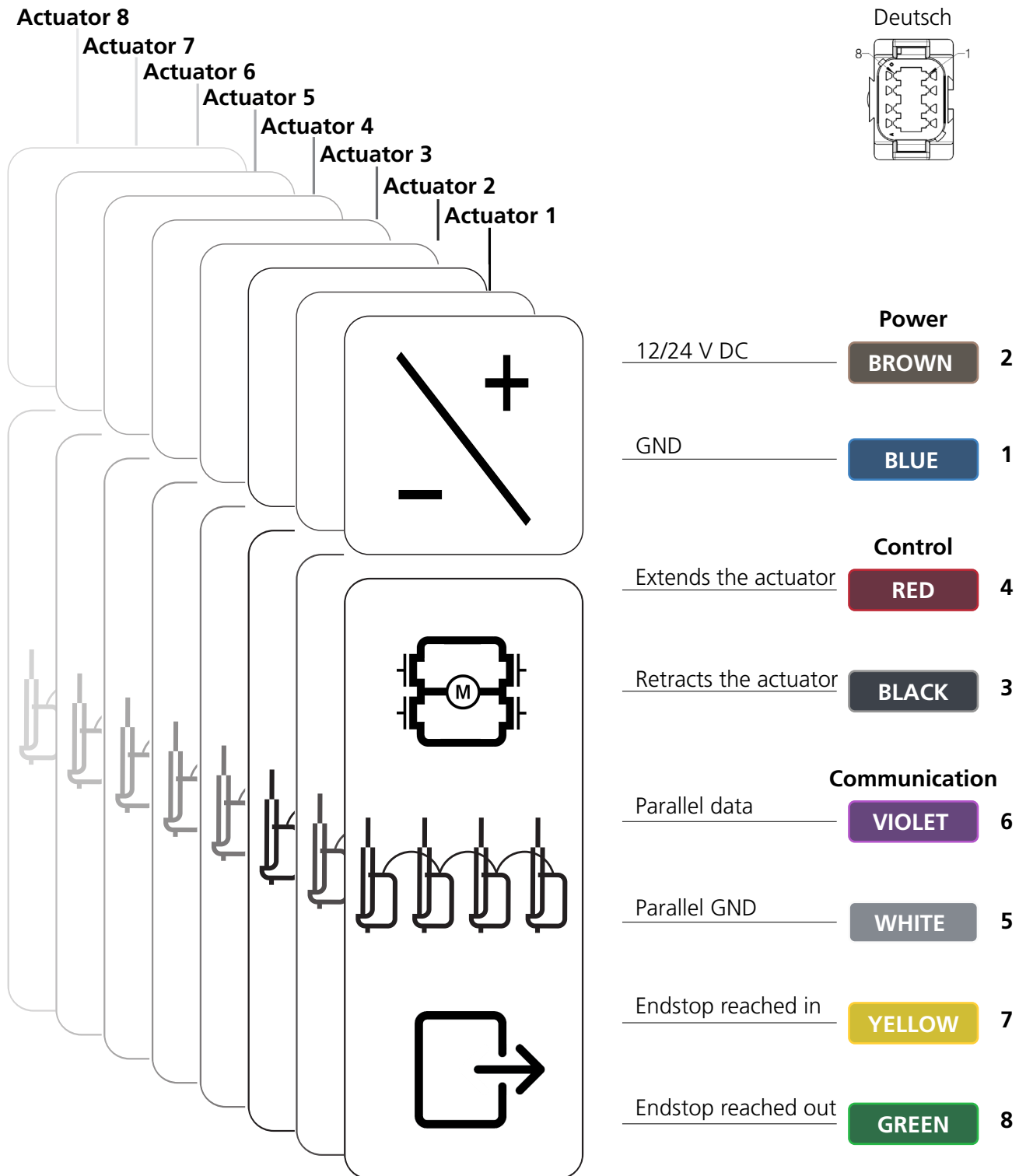

Please be aware that if the power supply is not properly connected, you might damage the actuator!

The Green and Yellow wires from parallel connected actuators must NOT be interconnected.

IC Parallel

Connection diagram

Applicable for: LA33, LA36 and LA37

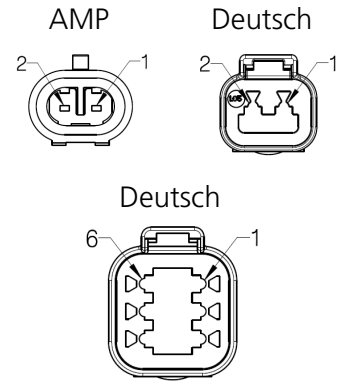
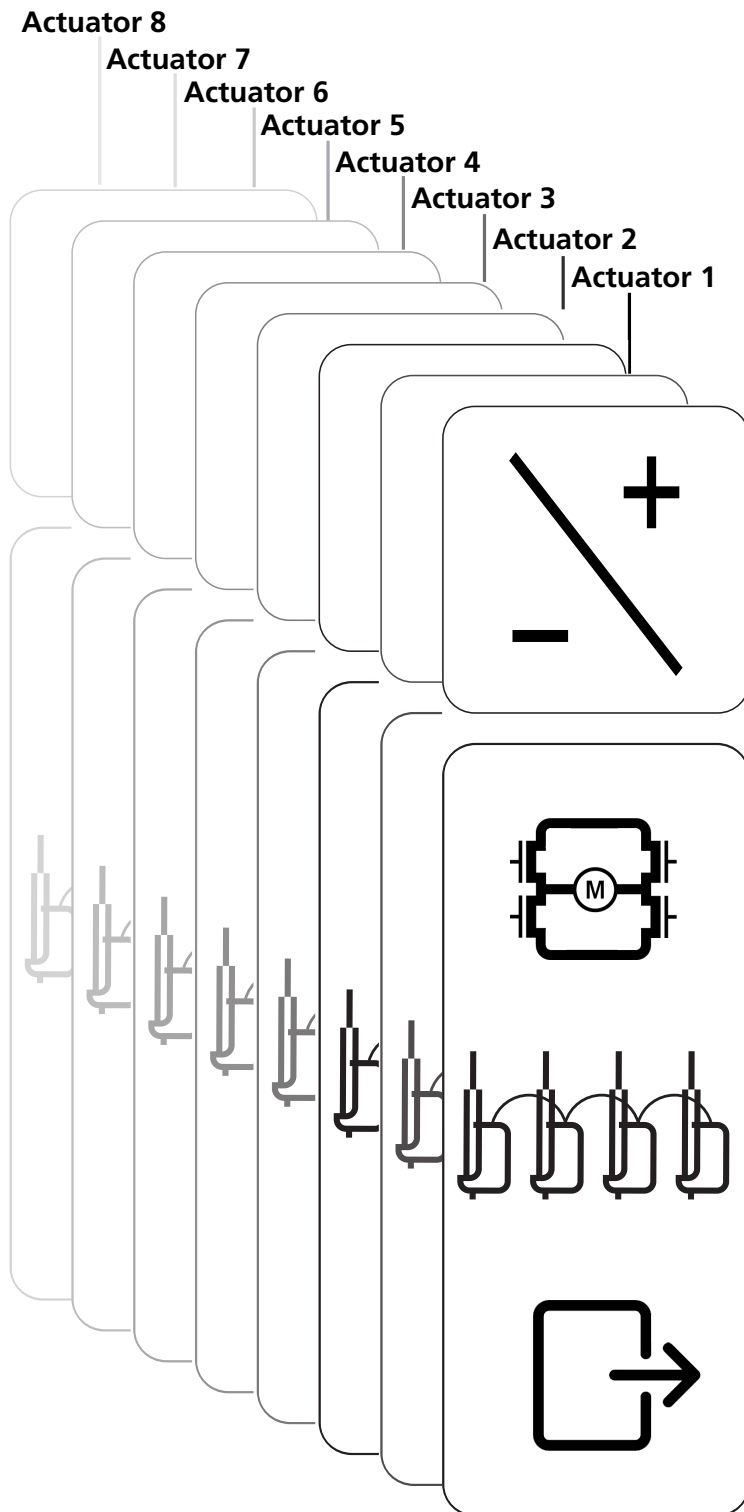

Power	
12/24 V DC	BROWN 2
GND	BLUE 1
Control	
Extends the actuator	RED 2
Retracts the actuator	BLACK 1
Communication	
Parallel data	VIOLET 4
Parallel GND	WHITE 3
Endstop reached in	YELLOW 5
Endstop reached out	GREEN 6



Please be aware that if the power supply is not properly connected, you might damage the actuator!

The Green and Yellow wires from parallel connected actuators must NOT be interconnected.

IC Parallel

I/O specifications

Applicable for: All actuators

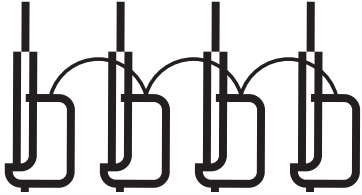
Input/Output	Specification	Comments
Description	Parallel drive of up to 8 actuators. A Master actuator with an integrated H-bridge controller controls up to 7 Slave actuators. The version with "IC option" cannot be operated with PWM (power supply).	
Brown	12 V DC \pm 20 % 24 V DC \pm 10 % Connect Brown to positive	The parallel actuators can run on one OR separate power supplies. Power supply GND (-) is electrically connected to the housing. Current limit levels can be adjusted through BusLink (one actuator at a time).
Blue	12/24 V DC - (GND) Connect Blue to negative	
Red	Extends the actuator	The signal becomes active at: > 67% of V_{IN} The signal becomes inactive at: < 33% of V_{IN} Input current: 10 mA It does not matter where the in/out signals are applied. You can either choose to connect the signal cable to one actuator OR you can choose to connect the signal cable to each actuator on the line. Either way this will ensure parallel drive.
Black	Retracts the actuator	
Yellow	Endstop reached in	Output voltage min. $V_{IN} - 2$ V Source current max. 100 mA Endstop reached signals are NOT potential free. Endstop reached signals can be configured with BusLink software according to any position needed.
Green	Endstop reached out	
Violet	Parallel data: Violet cords must be connected together	Standby power consumption: LA14 and LA25: 12 V: 60 mA 24 V: 45 mA LA33, LA36 and LA37: 12 V: 85 mA 24 V: 50 mA No feedback available during parallel drive
White	Parallel GND: White cords must be connected together	For correct wiring of Parallel GND - please see figure on the next page

The parallel system

Applicable for: All actuators

The Parallel drive function will support a number of actuators working jointly:

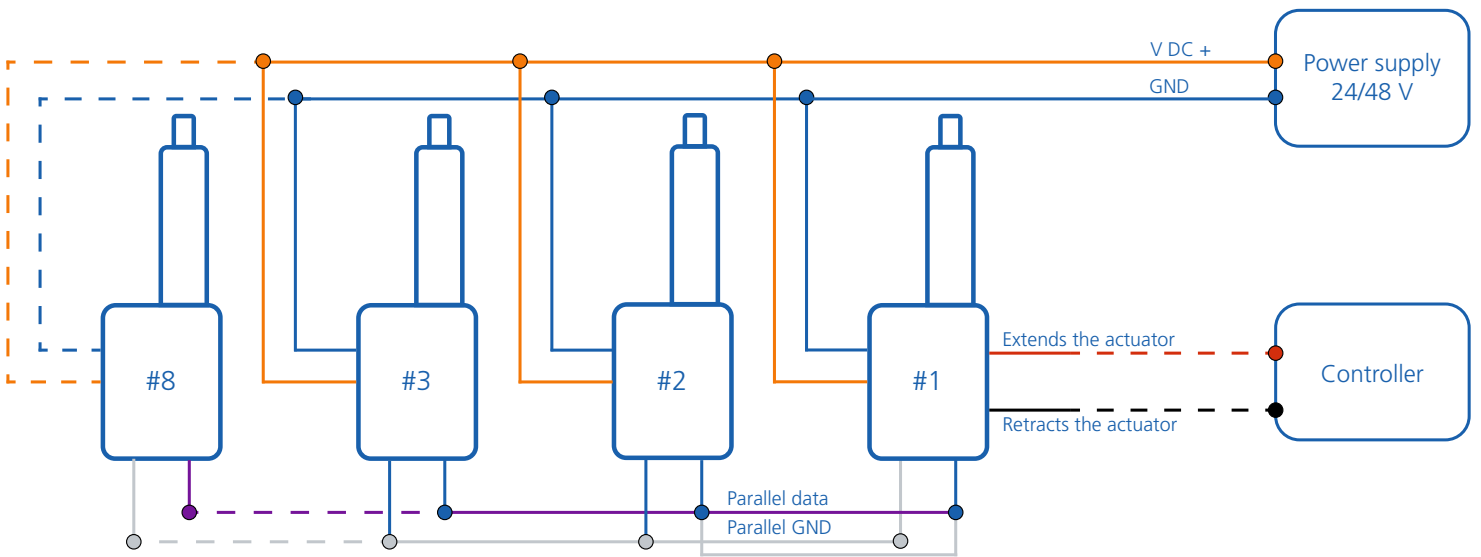

LA33, LA36 and LA37 requires two cables (power and signal).



Only standard power and signal cables are available for parallel.

It is also possible to use two separate power supplies in parallel under the condition that they have the same voltage and wattage output. It is essential that both power supplies share a common ground connection (Blue wire).

BusLink software tool and the parallel system

The BusLink software tool is available for parallel and can be used for:

Configuration, manual run and diagnostics (service counter)

The BusLink software can be downloaded [here](#).

For more information and easy set-up of BusLink, please follow [this link](#) to view the User Guide for BusLink.



Please note that the BusLink cables must be purchased separately from the actuator!
Item number for BusLink cable kit:



Only through the BusLink software tool is it possible to state if the system is Parallel or Non-Critical Parallel. Via this tool it is also possible to reconfigure the whole system from one system to the other.

The parallel system

- The actuators can be powered by the same or separate power supplies, but if separate supplies are used, it is crucial that all power supply grounds (GNDs) are connected together and that the power supplies have the same voltage output. Please respect the actuator specifications regarding voltage level and current consumption!
- If an overload occurs, the running of the actuators will be stopped and blocked in that direction until an activation in the opposite direction has been made, or the system has been re-powered.
- When changing the actuator configuration, it is important that all actuators in the system have the same configuration before the system starts running. Otherwise, the actuators will not run.
- When actuators are networked, control of their movement is achieved by applying a signal to the IN or OUT wire on one, several, or all actuators. By default, actuators begin moving IN/OUT when voltage V DC is applied to the Red or Black wire.
- Actuators will be pre-programmed from production as 2, 3, 4, 5 etc. parallel systems. Through BusLink it will be possible to add or remove actuators to/from the system.
- Before entering BusLink mode, all actuators must be disconnected. It is only possible to configure one actuator at a time through BusLink.
- When all actuators are connected, a Master will automatically be chosen. E.g. with 5 actuators in one system there will be 1 Master and 4 Slaves. The Master can control up to 7 Slaves.
- If a run out and run in command are given simultaneously to any actuator, the system will stop. To resume movement, one of the commands must be released. Similarly, if an outward command is given to any actuator and an inward command to another at the same time, the system will stop. Movement will resume when one of the commands is released.
- In case an actuator drops off the line due to e.g. a damaged signal cable, the parallel system will stop immediately.

The parallel system

- In a critical system, the required number of actuators is pre-configured. As a result, the system will remain inoperable regardless of repowering if the correct number of actuators is not present.
- The term “critical” is used to describe a system where any error, such as actuators not moving in parallel, could result in damage to the application or personal injury. Therefore, it is crucial to ensure that the correct number of actuators required for parallel movement is always present in the system. If one or more actuators are missing or malfunctioning, the system must stop immediately. It is important to consider both the network and mechanical response times.

Only for non-critical parallel systems

- The non-critical parallel system offers auto-detection for every single power-up if a new actuator is added to the line (system). Non-critical systems should only be used when there is no risk of damaging the application if one of the actuators is missing.
- To add or remove actuators from the system, the system needs to be shut down and powered up again. Please be aware that after re-powering, the system will not detect if an actuator is missing!
- If adding a new actuator to the system, be aware that the actuator needs to have the same configuration (Non-critical parallel) as the existing ones; this can be done via the BusLink software tool.
- In a non-critical system, the system will become inoperable due to discrepancies in the required number of actuators for each actuator. To resolve this, the system must be repowered so that all actuators can recognize the new configuration.

System Monitoring for Parallel



If one of the actuators has one of the following error conditions, the actuator will immediately STOP:

- H-Bridge fault
- Out of the temperature range (High duty cycle protection)
- Overcurrent (Current cut-off if one or all actuators go in mechanical block)
- SMPS fault
- Endstop reached signal fault switch
- Hall sensor failure
- Position lost
- Overvoltage

Alignment of the parallel actuator system

If the actuators are not in parallel when starting up, the next movement will run in the following manner:

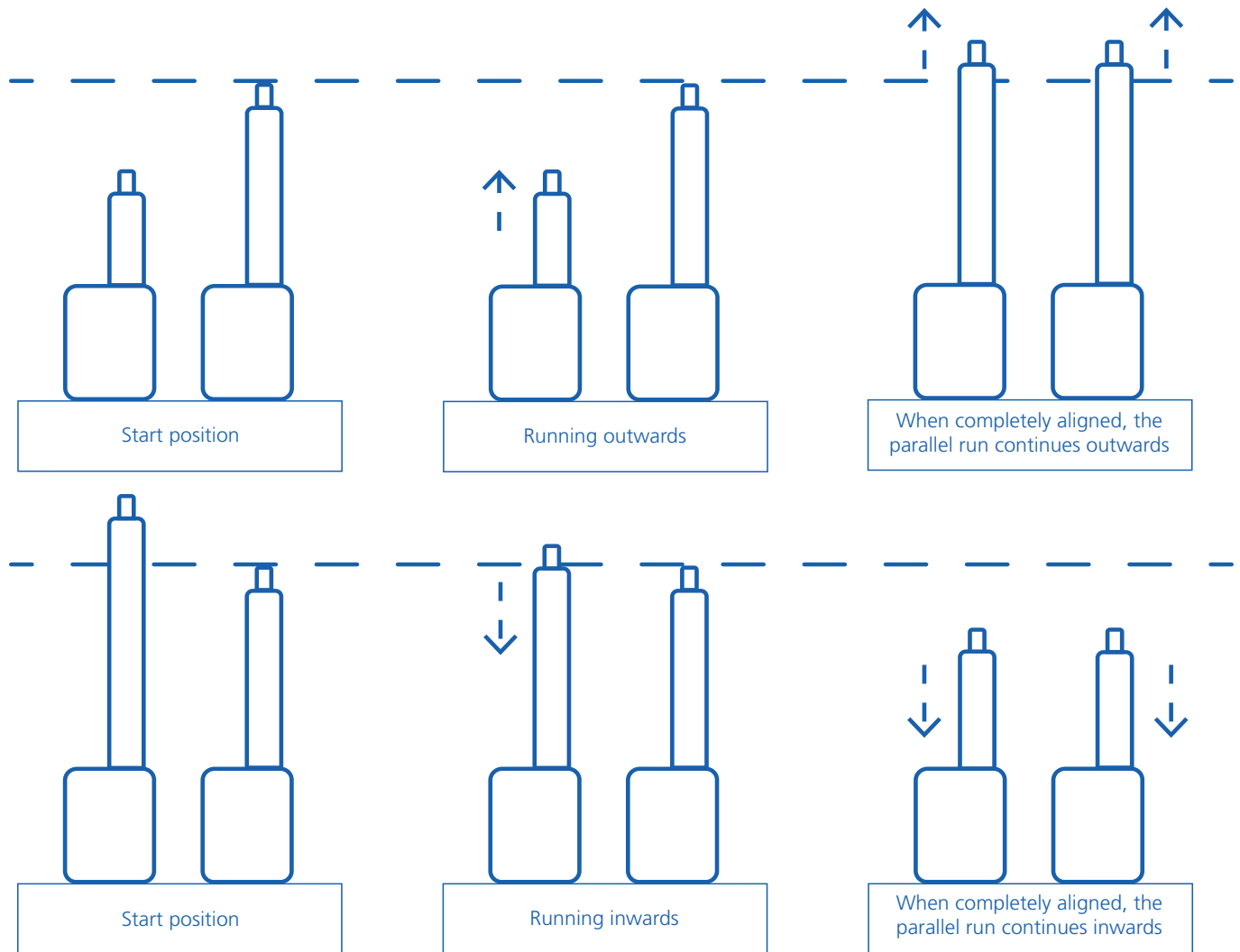

Position Lost and initialization

Occasionally, the actuator may enter a 'Position Lost' state when the stroke length and the position of the piston become misaligned. There are two primary scenarios that can trigger this 'Position Lost' condition:

1. Failure of Hall elements
2. Simultaneous Activation of End-of-Stroke (EOS) in both directions by the microcontroller

To maintain precise positioning and accurate feedback, it is strongly advised that the actuator regularly activates its limit switches.

When the actuator is in the 'Position Lost' state, the feedback level will remain at its maximum until the actuator is properly initialized. For example, if the feedback range is 0-10 V, the feedback level will stay at 10 V until initialization occurs.

For correct initialization of the feedback, both physical endstop switches must be activated. There is no specific order in which these switches need to be activated.

Recovery Run mode

The purpose of Recovery Run mode is to have the ability to move the actuators at a reduced performance, even if one of the actuators in the system has lost its position (due to e.g. failure with cyclic redundancy check, Hall or Endstop reached signal). The movement in steps will indicate to the user that something is wrong.

Since the position is unknown to at least one actuator in the system, the parallel system will move without synchronisation. This introduces the risk of unaligned movement if one of the actuators is physically unable to move.

Recovery Run mode will not engage if a wrong number of actuators is connected in the system.

If Recovery Run mode is engaged, it will cause a movement as shown below:

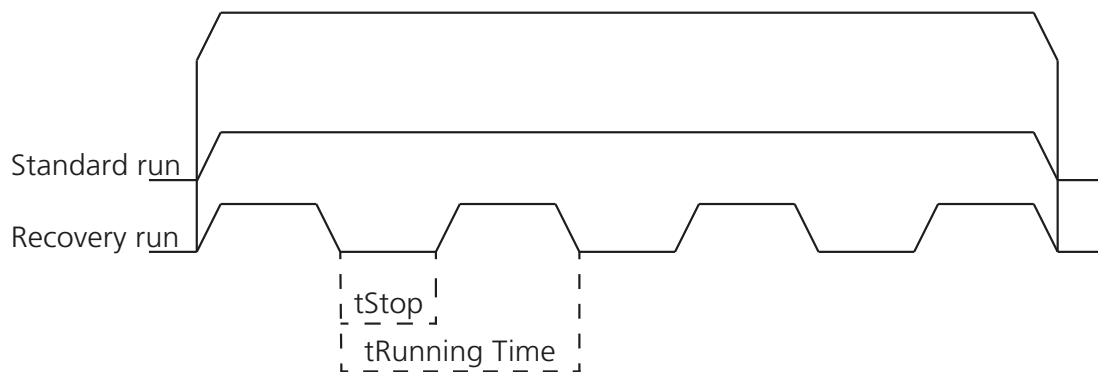

Recovery Run mode

tStop	2,000 ms
tRunning Time	4,000 ms

IC - Parallel manual service mode

With the Parallel Manual Service mode it is possible to drive one or more parallel actuators separately, using the Red and Black wire from each actuator.

An example: if there are 4 actuators in the system and one is removed, the remaining 3 actuators will still be operational simultaneously - so long as they are connected via the Violet and White wires, and given that 'Parallel manual service mode' is activated on at least one of them.

For activation of 'Parallel manual service mode' please follow the instructions below:

Step	Procedure	Min.	Max.
1. First step	Power up all remaining actuators in the system		
2. Hold	Put power on the Red and Black wires for 10-30 seconds.	10 s.	30 s.
3. Difference	The Red and Black wires must all be connected to the power supply within 0.5 seconds.	0 s.	0.5 s.
4. Release	Disconnect both wires and wait 0.5-2 seconds before the next step.	0.5 s.	2 s.
5. Extend/Retract	Now choose either to extend or retract the actuator: To extend the actuator: Connect only the Red wire(s) to the power supply. To retract the actuator: Connect only the Black wire(s) to the power supply.	-	-
6. Interval	Switch between running in/out as much as needed, without exceeding the 2.0 seconds interval between disconnecting/connecting the Red and Black wires	-	2 s.
7. End	To exit the parallel manual mode, disconnect the Red and Black wires for more than 2.0 seconds	2 s.	-

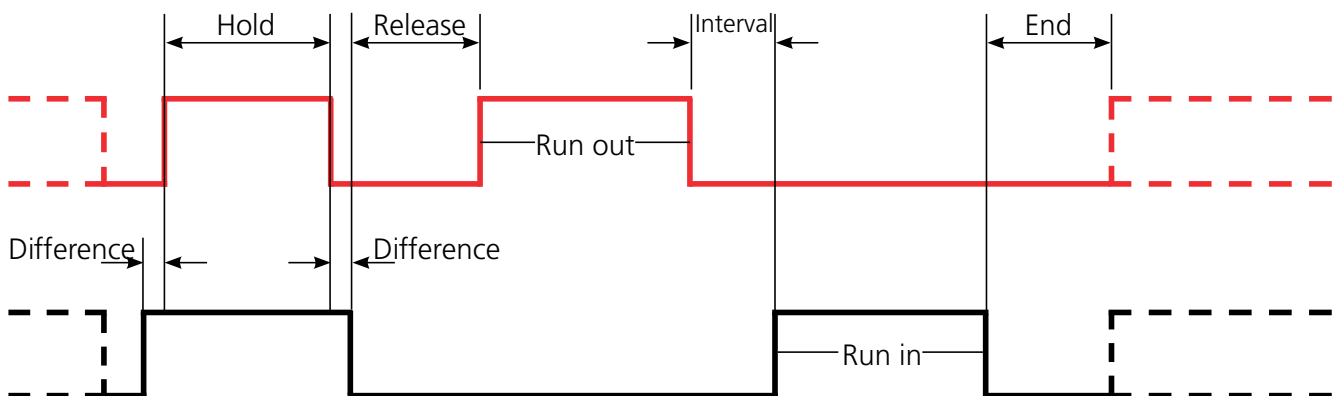

Standard run

Digital standard run is a well-known way of controlling an actuator with an integrated H-bridge. A high or low digital signal must be applied as described below, and this will cause the actuator to either run or stop. By default, the Red wire is used to drive the actuator in the outwards direction, and the Black wire is used for the inwards direction. The input current of this signal must be at least 10 mA.

When the signal is more than $\frac{2}{3}$ of VCC (VCC = 12 V DC or 24 V DC), it will be considered high, and the actuator will start running. If the signal is less than $\frac{1}{3}$ of VCC, it will be considered low, and the actuator will stop. When a high signal is applied to either the Red or Black wire, the voltage level can vary down to $\frac{1}{3}$ of VCC before it stops. After a stop, the voltage level must be more than $\frac{2}{3}$ of VCC before the actuator starts running again. This is visualised in the graphics below:

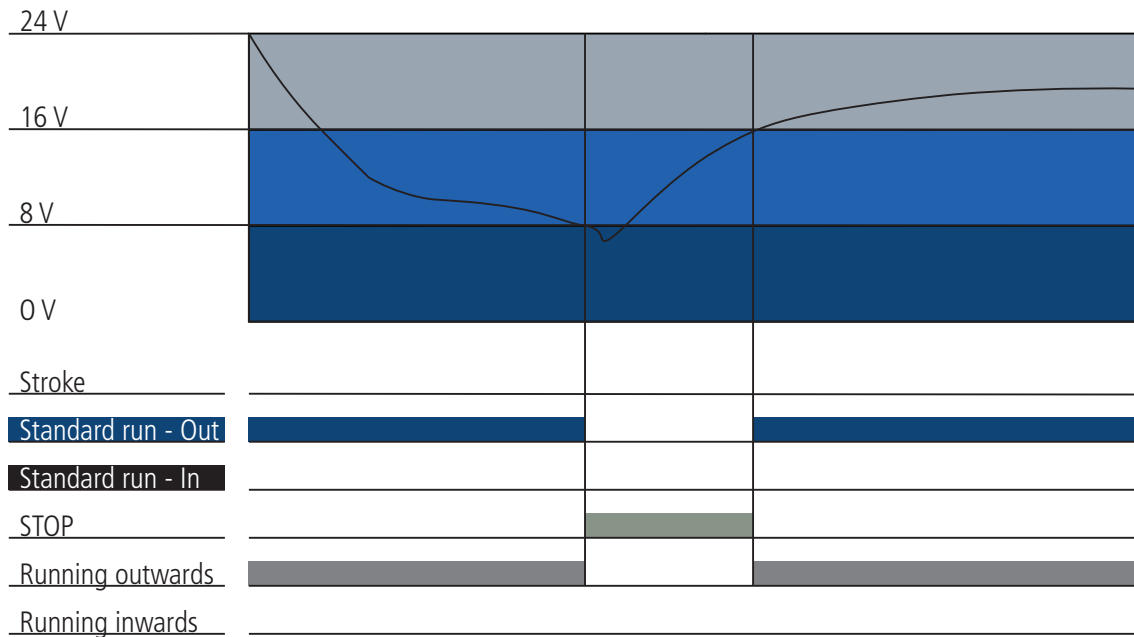

Virtual limits

Virtual zones are specifically designed to adapt to customer applications where tolerances may change over time or vary at the end of the stroke. In some cases, reaching the physical or virtual End of Stroke (EOS) may not be possible due to application limitations and tolerances.

Virtual End of Stroke settings can be predefined at the factory or configured using the BusLink software tool, which can be downloaded [here](#).

It is only possible to set one virtual limit in either direction. This limitation is due to the initialisation system at the end of the stroke. Therefore, it is essential for the actuator to reach the physical end of the stroke to ensure accurate initialisation and precision of the virtual limit position.

Endstop reached signal

The Endstop reached signal can be used to determine when the piston rod reaches the physical end of the stroke in the inwards or outwards direction. If a virtual limit is set, the actuator will also send an Endstop reached signal.

Active high (default)

When the signal is active high, the signal output will become high (VCC-1 V) when the piston rod reaches the end of the stroke. The signal output will remain high as long as the piston rod is not running in the opposite direction, or the actuator is powered off. If the actuator is re-powered, the Endstop signal will be high if the actuator is kept in the same position as previously. The digital signal between the two endstops will be considered as low (0 V), as illustrated here:

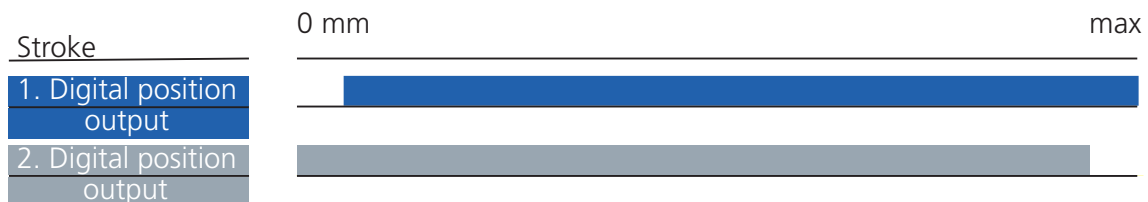

Active low

By choosing an active low signal, the digital output will have a high signal (VCC-1 V) when the actuator is operated between the two endstops. When the actuator reaches an endstop, the signal will become low (0 V), as long as the actuator is not running in the opposite direction, as illustrated here:



Hysteresis for Endstop reached signal

The actuator has a high self-locking ability, which ensures that the actuator maintains its position when stopped and load is applied. Depending on the mechanics (gearbox and spindle) and the applied load, there is a risk of back driving away from the endstop position. Hysteresis allows you to keep the signal high on the endstop output, even when the actuator has moved slightly away from the physical or virtual endstop. The default value is set to two pulses from the Hall magnet, which is between 0.2-1.4 mm (depending on actuator model)

Soft start and soft stop

Starting an actuator too fast potentially results in a large current draw and increased mechanical stress. When soft stopping, the actuator and application inertia will generate power by driving the DC motor. If the soft stop timeframe is too short, the actuator supply voltage may rise above the load dump limit. For soft start and soft stopping, several parameters can be configured to reduce the stress of the actuator and customer application. These parameters can also reduce current spikes during starting and reduce voltage peaks when stopping. The default values are set to 300 ms for both soft start and soft stop.

Soft stop refers to the deceleration time. The actuator initiates the deceleration time, as soon as the Red or Black wire is disconnected. With a soft stop, you select a timeframe for the actuator to slow down to zero after the stop signal is applied. The time can be set between 0 (hard stop) and 30 s., except for 0.1-299 ms. This is because the actuator is unable to redirect/consume the accumulated energy in a 0.1-299 ms stop.

Speed

- Speed without Soft Stop: 100% of VCC
- Configurable recommendable minimum speed: Down to 60%
- Speed with Towards Soft Stop: Maximum of 80% of VCC

The speed is determined using a PWM (Pulse Width Modulation) principle, where 100% corresponds to the voltage supplied to the actuator input rather than the actual speed. The lowest recommended speed under full load conditions is 60%. While it is possible to reduce the speed below this threshold, the feasibility depends significantly on the load, power supply, and specific application.

When the “towards soft stop” option is selected, the speed can be reduced to a maximum of 80%. This means that if the speed is configured to 100% in the BusLink, the actuator will only operate at 80% of its maximum speed.

Current cut-off

The current cut-off principle operates using an accumulating counter that tracks current levels. It counts upwards when the current exceeds a specified limit and counts downwards when it falls below that limit. For instance, if the current limit time-out is set to 200 ms, the actuator's current must exceed the maximum threshold (20 amps in this example) for more than 200 ms before the cut-off is triggered.

Additionally, if the motor is activated in one direction, it must be blocked from activating in the same direction again until a reset is performed by activating in the opposite direction.

It is important to note that current cut-offs should not be relied upon as a general stop function, as this could lead to long-term damage to the actuator. They should only be employed in emergency situations. Furthermore, current cut-off limits do not correlate directly with the actuator's load curves, meaning they should not be used as indicators of load. Various tolerances in components such as the spindle, nut, and gears can also affect the current consumption of the actuator.

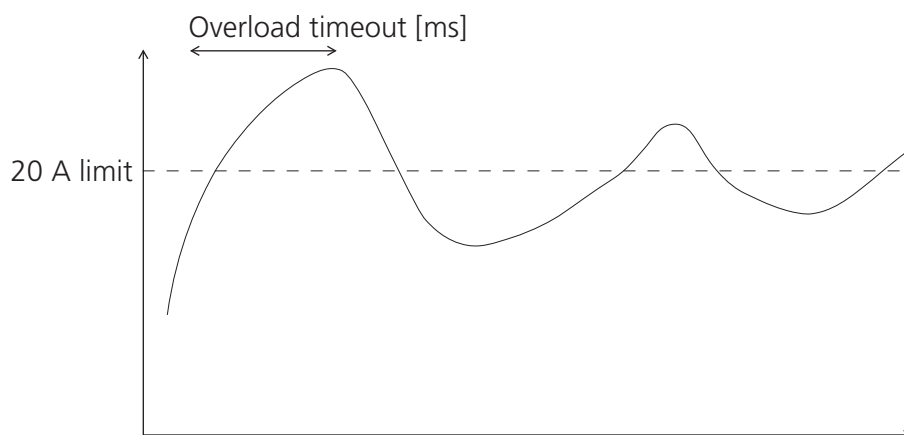

For more information about standard current cut-off values, please see the table below:

	Unit	LA14		LA25		LA33		LA36		LA37	
		12 V	24 V	12 V	24 V	12 V	24 V	12 V	24 V	12 V	24 V
Inwards / Outwards Above reference limit	[A]	8	5	8	5	15	10	30	20	30	20
Inwards / Outwards Below reference limit	[A]	9	9	9	6	20	15	30	25	30	25
Reference limit	[°C]	-10		-5		0		0		0	
Overload timeout	[ms]	500		500		200		200		200	

Contacts

FACTORIES

Denmark - Headquarters
 LINAK A/S
 Phone: +45 73 15 15 15
 Fax: +45 74 45 80 48
 Fax (Sales): +45 73 15 16 13
 Web: www.linak.com

China
 LINAK (Shenzhen) Actuator Systems, Ltd.
 Phone: +86 755 8610 6656
 Phone: +86 755 8610 6990
 Web: www.linak.cn

Slovakia
 LINAK Slovakia s.r.o.
 Phone: +421 51 7563 444
 Web: www.linak.sk

Thailand
 LINAK APAC Ltd.
 Phone: +66 33 265 400
 Web: www.linak.com

USA
 LINAK U.S. Inc.
 Americas Headquarters
 Phone: +1 502 253 5595
 Phone: +1 502 253 5596
 Web: www.linak-us.com
 www.linak-latinamerica.com

SUBSIDIARIES

Australia
 LINAK Australia Pty. Ltd
 Phone: +61 3 8796 9777
 Fax: +61 3 8796 9778
 E-mail: sales@linak.com.au
 Web: www.linak.com.au

Austria
 LINAK Zweigniederlassung - Österreich (Wien)
 Phone: +43 (1) 890 7446
 Fax: +43 (1) 890 744615
 E-mail: info@linak.de
 Web: www.linak.at - www.linak.hu

Belgium
 LINAK Actuator-Systems NV/SA
 (Belgium & Luxembourg)
 Phone: +32 (0)9 230 01 09
 E-mail: beinfo@linak.be
 Web: www.linak.be - www.fr.linak.be

Brazil
 LINAK Do Brasil Comércio De Atuadores Ltda.
 Phone: +55 (11) 2832 7070
 Fax: +55 (11) 2832 7060
 E-mail: info@linak.com.br
 Web: www.linak.com.br

Canada
 LINAK Canada Inc.
 Phone: +1 502 253 5595
 Fax: +1 416 255 7720
 E-mail: info@linak.ca
 Web: www.linak-us.com

Czech Republic
 LINAK C&S s.r.o.
 Phone: +42 058 174 1814
 Fax: +42 058 170 2452
 E-mail: info@linak.cz
 Web: www.linak.cz - www.linak.sk

Denmark - International
 LINAK International
 Phone: +45 73 15 15 15
 E-mail: info@linak.com
 Web: www.linak.com

Denmark - Sales
 LINAK Danmark A/S
 Phone: +45 86 80 36 11
 Fax: +45 86 82 90 51
 E-mail: linak@linak-silkeborg.dk
 Web: www.linak.dk

Finland
 LINAK OY
 Phone: +358 10 841 8700
 E-mail: linak@linak.fi
 Web: www.linak.fi

France
 LINAK France E.U.R.L
 Phone: +33 (0) 2 41 36 34 34
 Fax: +33 (0) 2 41 36 35 00
 E-mail: linak@linak.fr
 Web: www.linak.fr

Germany
 LINAK GmbH
 Phone: +49 6043 9655 0
 Fax: +49 6043 9655 60
 E-mail: info@linak.de
 Web: www.linak.de

India
 LINAK A/S India Liaison Office
 Phone: +91 120 4531797
 Fax: +91 120 4786428
 E-mail: info@linak.in
 Web: www.linak.in

Ireland
 LINAK UK Limited (Ireland)
 Phone: +44 (0)121 544 2211
 Fax: +44 (0)121 544 2552
 +44 (0)796 855 1606 (UK Mobile)
 +35 387 634 6554 (Rep.of Ireland Mobile)
 E-mail: sales@linak.co.uk
 Web: www.linak.co.uk

Italy
 LINAK ITALIA S.r.l.
 Phone: +39 02 48 46 33 66
 Fax: +39 02 48 46 82 52
 E-mail: info@linak.it
 Web: www.linak.it

Japan
 LINAK K.K.
 Phone: 81-45-533-0802
 Fax: 81-45-533-0803
 E-mail: linak@linak.jp
 Web: www.linak.jp

Malaysia
 LINAK Actuators Sdn. Bhd.
 Phone: +60 4 210 6500
 Fax: +60 4 226 8901
 E-mail: info@linak-asia.com
 Web: www.linak.my

Netherlands
 LINAK Actuator-Systems B.V.
 Phone: +31 76 5 42 44 40 /
 +31 76 200 11 10
 E-mail: info@linak.nl
 Web: www.linak.nl

New Zealand
 LINAK New Zealand Ltd
 Phone: +64 9580 2071
 Fax: +64 9580 2072
 E-mail: nzsales@linak.com.au
 Web: www.linak.com.au

Norway
 LINAK Norge AS
 Phone: +47 32 82 90 90
 E-mail: info@linak.no
 Web: www.linak.no

Poland
 LINAK Polska
 LINAK Danmark A/S (Spółka Akcyjna)
 Phone: +48 22 295 09 70 /
 +48 22 295 09 71
 E-mail: info@linak.pl
 Web: www.linak.pl

Republic of Korea
 LINAK Korea Ltd.
 Phone: +82 2 6231 1515
 Fax: +82 2 6231 1516
 E-mail: info@linak.kr
 Web: www.linak.kr

Slovakia
 LINAK Slovakia S.R.O.
 Phone: +421 51 7563 444
 Web: www.linak.sk

Spain
 LINAK Actuadores, S.L.u
 Phone: +34 93 588 27 77
 Fax: +34 93 588 27 85
 E-mail: esma@linak.es
 Web: www.linak.es

Sweden
 LINAK Scandinavia AB
 Phone: +46 8 732 20 00
 Fax: +46 8 732 20 50
 E-mail: info@linak.se
 Web: www.linak.se

Switzerland
 LINAK AG
 Phone: +41 43 388 31 88
 Fax: +41 43 388 31 87
 E-mail: info@linak.ch
 Web: www.linak.ch - www.fr.linak.ch
 www.it.linak.ch

Taiwan
 LINAK (Shenzhen) Actuator systems Ltd.
 Taiwan Representative office
 Phone: +886 2 272 90068
 Fax: +886 2 272 90096
 E-mail: sales@linak.com.tw
 Web: www.linak.com.tw

Turkey
 LINAK İth. İhr. San. ve Tic. A.Ş.
 Phone: +90 312 4726338
 Fax: +90 312 4726635
 E-mail: info@linak.com.tr
 Web: www.linak.com.tr

United Kingdom
 LINAK UK Limited
 Phone: +44 (0)121 544 2211
 Fax: +44 (0)121 544 2552
 E-mail: sales@linak.co.uk
 Web: www.linak.co.uk

DISTRIBUTORS

Argentina
 Novotec Argentina SRL
 Phone: 011-4303-8989 / 8900
 Fax: 011-4032-0184
 E-mail: info@novotecargentina.com
 Web: www.novotecargentina.com

Colombia
 MEM Ltda
 Phone: +[57] (1) 334-7666
 Fax: +[57] (1) 282-1684
 E-mail: servicioalcliente@memlda.com.co
 Web: www.mem.net.co

India
 Mechatronics Control Equipments India Pvt Ltd
 Phone: +91-44-28558484, 85
 E-mail: bala@mechatronicscontrol.com
 Web: www.mechatronicscontrol.com

Indonesia
 PT. Himalaya Everest Jaya
 Phone: +6 221 544 8956 /+6 221 544 8965
 Fax: +6 221 619 1925
 Fax (Sales): +6 221 619 4658
 E-mail: hejplastic-div@centrin.net.id
 Web: www.hej.co.id

Israel
 NetivTech LTD
 Phone: +972 55-2266-535
 Fax: +972 2-9900-560
 Email: info@NetivTech.com
 Web: www.netivtech.com

Singapore
 Servo Dynamics Pte Ltd
 Phone: +65 6844 0288
 Fax: +65 6844 0070
 E-mail: servodynamics@servo.com.sg

South Africa
 Industrial Specialised Applications CC
 Phone: +27 011 466 0346
 E-mail: gartht@isagroup.co.za
 Web: www.isaza.co.za

United Arab Emirates
 Mechatronics
 Phone: +971 4 267 4311
 Fax: +971 4 267 4312
 E-mail: mechtron@emirates.net.ae