

Kick & Click[™] User manual

Contents

Preface	3
Important information	4
Safety instructions	4
Before installation, re-installation or troubleshooting	5
Before start-up	5
During operation	5
Misc.	5
Only for EU markets	6
Only for Non EU markets	6
Misuse	6
Repairs	7
Manufacturer's declaration	7
Declaration of conformity	8
Misc. on the DESKLINE® system	9
Warranty	9
Maintenance	9
Description of the DESKLINE® Kick & Click™ system	10
Kick & Click™ Fixed	11
Kick & Click™ Adjustable	11
Kick & Click™ Base	12
Kick & Click™ 3 rd leg kit	13
Assembly	14
Kick & Click™ Adjustable (standard)	14
Kick & Click™ Adjustable (compact)	15
Assembling the Kick & Click system	16
Assembling a three-legged desk	19
Mounting the tabletop	20
Disassembly	22
Accessories	23
Disposal of LINAK's products	24
Drawing appendix	25
Addresses	34

Preface

Dear User,

We are delighted that you have chosen a product from LINAK®. LINAK systems are high-tech products based on many years of experience in the manufacture and development of actuators, electric control boxes, controls and chargers.

This User Manual does not address the end-user. It is intended as a source of information for the manufacturer of the equipment or system only, and it will tell you how to install, use and maintain your LINAK electronics. It is the responsibility of the manufacturer of the end-user product to provide a User Manual where relevant safety information from this manual is passed on to the end-user.

We are sure that your LINAK product/system will give you many years of problem-free operation. Before our products leave the factory, they undergo full function and quality testing. Should you nevertheless experience problems with your LINAK product/system, you are always welcome to contact your local contact. LINAK subsidiaries and some distributors situated all over the world have authorised service centres, which are always ready to help you.

LINAK provides a limited warranty on its products. This warranty is, however, subject to correct use in accordance with the specifications, maintenance being done correctly, and any repairs being carried out at a service centre, which is authorised to repair LINAK products. Changes in installation and use of LINAK products/systems can affect their operation and durability. The products are not to be opened by unauthorised personnel. You can review the full terms of the LINAK warranty on the LINAK website www.linak.com/warranty.

The User Manual has been written based on our present technical knowledge. We are constantly working on updating the information and we therefore reserve the right to carry out technical modifications.

LINAK A/S

Important information

Important information on LINAK® products can be found under the following headings:



Warning!

Failure to comply with these instructions may result in accidents involving serious personal injury.



Failing to follow these instructions can result in the product being damaged or being destroyed.

Safety instruction



General

Safe use of the system is possible only when the operating instructions are read completely and the instructions contained are strictly observed.

Failure to comply with instructions marked with the "NOTE" symbol may result in serious damage to the system or one of its components.



It is important for everyone who is to connect, install, or use the systems to have the necessary information and access to this User Manual. Follow the instructions for mounting – there is a risk of injury if these instructions are not followed.



The appliance is not intended for use by young children or infirm persons without supervision.



If there is visible damage to the product, do not install it.



Please note that during construction of applications in which the actuator is to be fitted, there must be no possibility of personal injury, for example squeezing of fingers or arms.



Assure free space for movement of the application in both directions to avoid blockades.

Before installation, re-installation, or troubleshooting:

- Stop the columns.
- Switch off the power supply and pull out the mains plug.
- Relieve the columns of any loads, which may be released during the work.

Before start-up:

- Make sure that the system has been installed as instructed in this User Manual. Describing the motor system.
- Make sure that the voltage of the control box is correct before connecting the system to the mains.
- System connection. The individual parts must be connected before connecting the control box to the mains. See the User Manual for LINAK actuators, if necessary.

During operation

- If the control box makes unusual noise or smells, switch off the mains voltage immediately.
- Duty Cycle: 10%, Max. 2 min./18 min. pause
- Take care that the cables are not damaged.
- Unplug the mains cable on mobile equipment before moving it.
- The products must only be used in an environment, that corresponds to their IP protection.

Misc.

For further information, installation guidelines etc. for the motor system, please see the relevant user manual: www.linak.com/deskline.

Updated manuals and declarations can always be found here:
www.linak.com/deskline.

Only for EU markets



This appliance can be used by children aged from aged 8 years and above and persons with reduced physical, sensory or mental capabilities or lack of experience and knowledge if they have been given supervision or instruction concerning use of the appliance in a safe way and understand the hazards involved.



Children shall not play with the appliance. Cleaning and user maintenance shall not be made by children without supervision.

Only for Non EU markets



Persons who do not have the necessary experience or knowledge of the product/products must not use the product/products. Besides, persons with reduced physical, sensory or mental abilities must not use the product/products, unless they are under surveillance or they have been thoroughly instructed in the use of the apparatus by a person who is responsible for the safety of these persons.



Moreover, children must be under surveillance to ensure that they do not play with the product.



It is the operator's responsibility to ensure that there is free space for the application to move without risk for the operator or bystanders before operating the application.

Misuse



Do not overload the actuators – this can cause danger of personal injury and damage to the system.



Do not use the actuator system for lifting persons. Do not sit or stand on a table while operating – risk of personal injury.



Do not use the system in environments other than the intended indoor use

Repairs

In order to avoid the risk of malfunction, all DESKLINE® repairs must only be carried out by authorised LINAK service centres or repairers, as special tools must be used and special gaskets must be fitted. Products under warranty must also be returned to authorised LINAK service centres.

Further information on DESKLINE warranty can be found on the LINAK website www.linak.com/warranty.



Warning!

If any of the DESKLINE® products are opened, there will be a risk of subsequent malfunction.



Warning!

The DESKLINE® systems do not withstand cutting oil.

DECLARATION OF INCORPORATION OF PARTLY COMPLETED MACHINERY

LINAK A/S
Smedevænget 8
DK - 6430 Nordborg

Herewith declares that LINAK DESKLINE® products as characterized by the following models and types:

Control Boxes	CBD6S
Linear Actuators	DB5, DB6, DB7, DB9, DB12, DB14, DB16, LA23, LA31
Lifting Columns	DL1A, DL2, DL4S, DL5, DL6, DL7, DL8, DL9, DL10, DL11, DL12, DL14, DL15, DL16, DL17, DL19, BASE1
Desk Panels	DPA, DPB, DPH, DPF, DPG1K, DPG1M, DPG1B, DPG1C, DPT, DP1, DP1CS, DP1K, DP1V, DP1U
RF Controls	HB10RF, HB20RF, RFT, RFRL
Accessories	BA001, SLS, Kick & Click

comply with the following parts of the Machinery Directive 2006/42/EC, ANNEX I, *Essential health and safety requirements relating to the design and construction of machinery*:

1.5.1 Electricity supply

The relevant technical documentation is compiled in accordance with part B of Annex VII and that this documentation or part hereof will be transmitted by post or electronically to a reasoned request by the national authorities.

This partly completed machinery must not be put into service until the final machinery into which it is to be incorporated has been declared in conformity with the provisions of the Machinery Directive 2006/42/EC where appropriate.

Nordborg, 2017-12-08

LINAK A/S
John Kling, B.Sc.E.E.
Certification and Regulatory Affairs
Authorized to compile the relevant technical documentation

DECLARATION OF CONFORMITY

LINAK A/S
Smedevænget 8
DK - 6430 Nordborg

hereby declares that LINAK Actuator System composed of:

Control Box(s) CBD6SP00020A-309
 CBD6S*000*0A-709

(The "*" in the product description can either be a character or a number, thereby defining the variation of the product)

And

Linear Actuator(s) 31, DB4, DB5, DB6, DB7, DB9, DB12, DB14, DB16, LA23 series and / or
Lifting Column(s) DL1A, DL2, DL4, DL5, DL6, DL7, DL8, DL9, DL10, DL11, DL12, DL14, DL15, DL16, DL17, DL19,
 BASE1 series

And

Desk Panel(s) DP1C, DP1K, DP1L, DP1V, DP1U, DPA, DPB, DPF, DPG, DPH, DPT, WDPL1 series

complies with EMC Directive: 2014/30/EU according to following standards:
EN 61000-6-1:2007, EN 61000-6-3:2007+A1:2011+AC:2012

complies with Low Voltage Directive 2014/35/EU according to the standard:
EN 60335-1:2012+A11:2014

complies with RoHS2 Directive 2011/65/EU according to the standard:
EN 55581:2012

Additional information:

The system does also comply with the standard: EN 13849-1:2015 SRP/CS Cat. B, PL = b and SRESW PL = b
Note 1: Exempted CBD6S with SW03003007 printed on the label.

Nordborg, 2017-12-08



LINAK A/S
John Kling, B.Sc.E.E.
Certification and Regulatory Affairs
Authorized to compile the relevant technical documentation

Original Declaration

Misc. on the DESKLINE® system

This system is a DESKLINE system developed for desks and for indoor use in offices. Do not use it in industrial kitchens or in other environments that have to be cleaned with aggressive detergents.

Warranty

This DESKLINE product is subject to warranty pursuant to the terms of LINAK DESKLINE Warranty Paper, available on the LINAK website www.linak.com/warranty.

Maintenance

Clean dust and dirt off the outside of the system at appropriate intervals and inspect them for damage and breaks. Inspect the connections, cables, and plugs and check for correct functioning as well as fixing points.

Description of the DESKLINE® Kick & Click™ system

The Kick & Click™ system is the smart and intuitive solution for mounting DESKLINE™ columns to the tabletop. The solution is perfect for various office desks. The unique feature of Kick & Click is the way of mounting. Click the system together without using tools and screws, simply clever. Kick & Click is a modular concept compatible with all DESKLINE® columns with motor housing leaving the design to the desk manufacturer. Kick & Click comes standard in 3 variants: Kick & Click Adjustable (standard or compact), Kick & Click Fixed and Kick & Click Base. Additionally, Kick & Click can be used for creating large three-legged office desks by joining a Kick & Click 3rd leg kit with a Kick & Click system.

Kick & Click™: names of the different parts

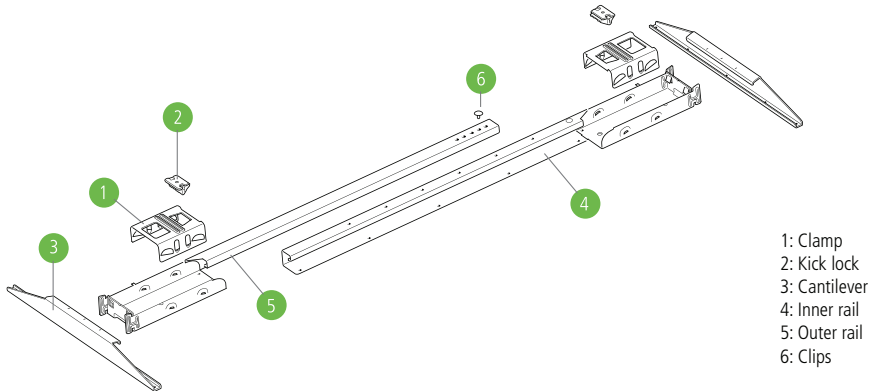

Features for all versions:

- Max. total load (including the tabletop):
 - Two-legged desks: 160 kg equally loaded, i.e. 80 kg on each column
 - Three-legged desks: 240 kg equally loaded, i.e. 80 kg on each column
- Colour (all metal parts): Available in black (RAL 9005), grey (RAL 9006), or white (RAL 9016)
- Cantilever length: 550 mm
- Oval holes ensure flexibility as regards pre-drilling holes in tabletop
- Central or off-centre placement of columns (T-desk or C-desk)

Kick & Click™ Fixed:

- Fits desks of 1200 mm (frame width 1140 mm)
- Set-packed or bulk deliveries
- Can be delivered with screws for mounting the tabletop

Kick & Click™ Adjustable:

- Fits desks
 - Standard: from 1400 to 2000 mm (frame width 1340 to 1940 mm)
 - Compact: from 1000 to 1300 mm (frame width 940 to 1240 mm)
- Set-packed (both versions) or bulk deliveries (standard version only)
- Can be delivered with screws for mounting the tabletop

Kick & Click™ Base:

- Base consists of Cantilever (x2), Base (x2), Clamp (x2) and Kick Lock (x2) for a two-legged desk
- Bulk deliveries only

Kick & Click™ Fixed

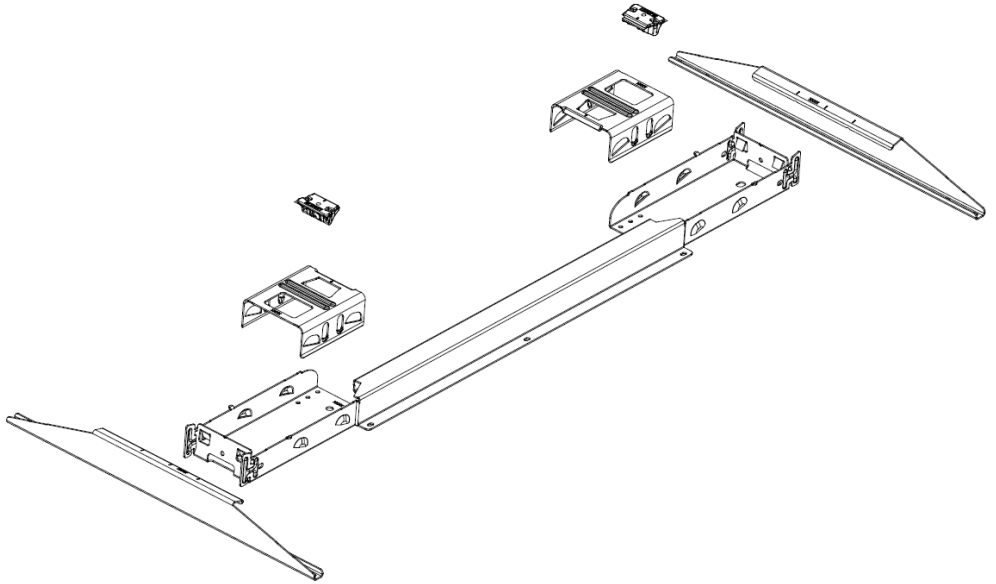

Compared to the Adjustable system the Fixed system only consists of one rail which is welded onto the base in both ends.

Kick & Click™ Adjustable

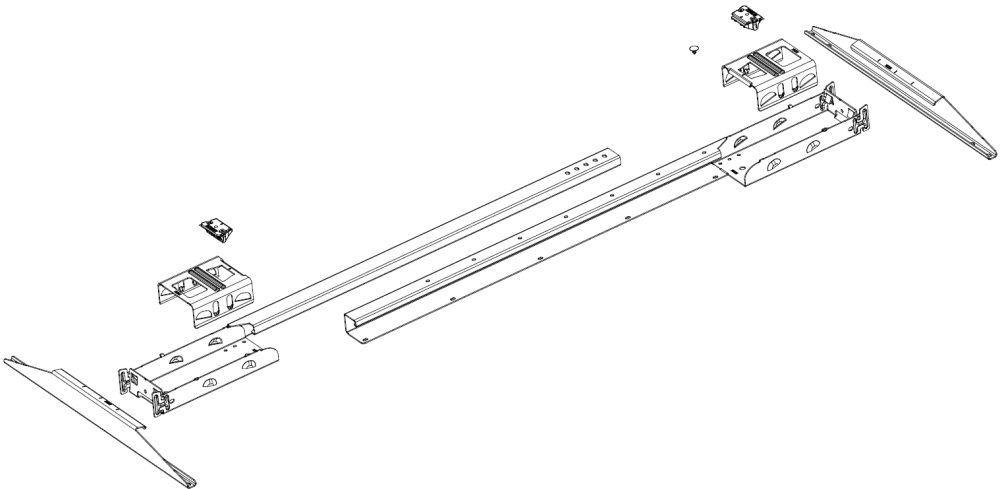

The Adjustable system includes a telescopic inner and outer rail onto which the base is welded.

Kick & Click™ Base

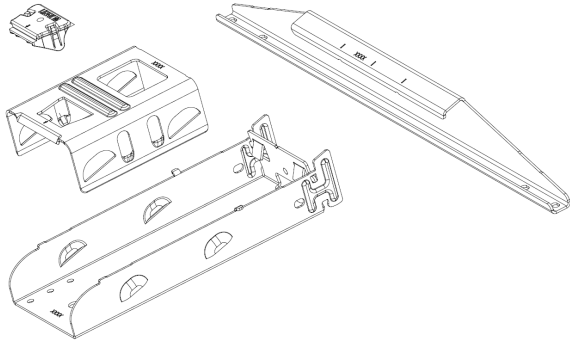

The Base system is without the inner and the outer rail. The system is preferred if the OEM want to weld his own rail onto the Base, or if the desk design does not need a rail e.g. due to tabletop thickness. The Base system could also be used for a 3 leg desk.

The allowed welding area (shaded) on the base is shown here:

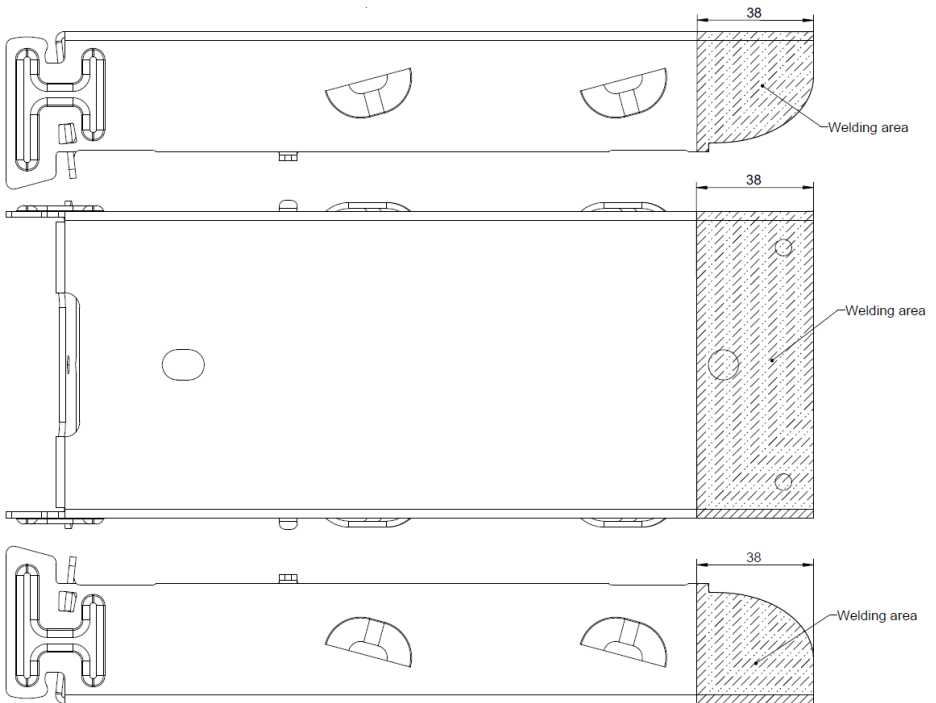

The Kick & Click base must only be used in connection with a Kick & Click cantilever.
Do not develop your own cantilever!

Kick & Click™ 3rd leg kit

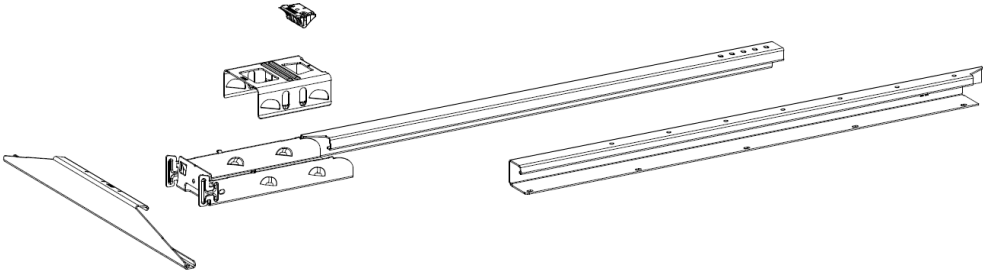

The 3rd leg kit system includes a telescopic inner and outer rail with a base welded onto the outer rail.

Assembly

A mounting instruction video is available [here](#).

Table size and type

The Kick & Click is designed for T-desks and C-desks. The cantilevers must be mounted centrally on the tabletop.

Kick & Click adjustable (standard)

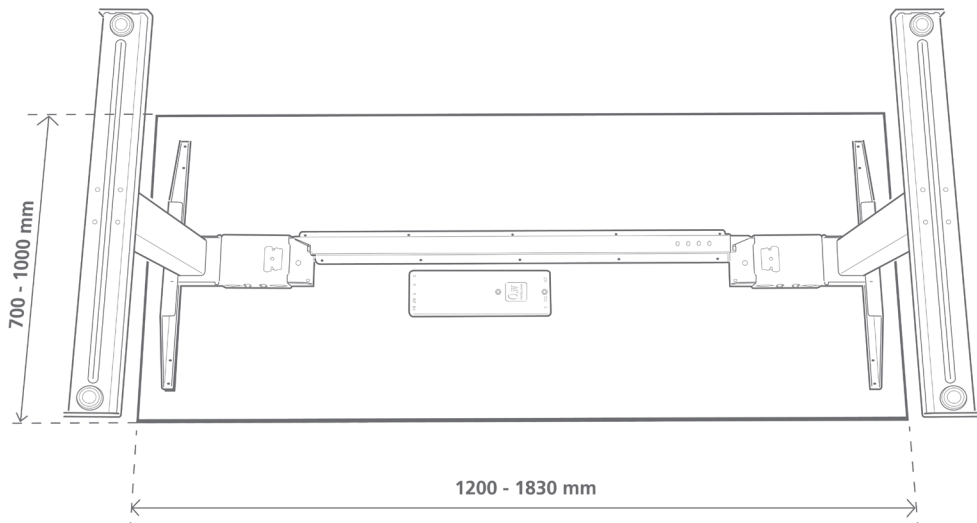

Kick & Click Adjustable (standard) and control box mounted on the tabletop (cantilevers centrally placed)



Recommended tabletop

Material	Veneered chipboard Plywood
Thickness	Min 21 mm (13/16")
Size	Min. 700 x 1200 mm (27" x 47") Max. 1000 x 1830 mm (39" x 72")

Kick & Click adjustable (compact)

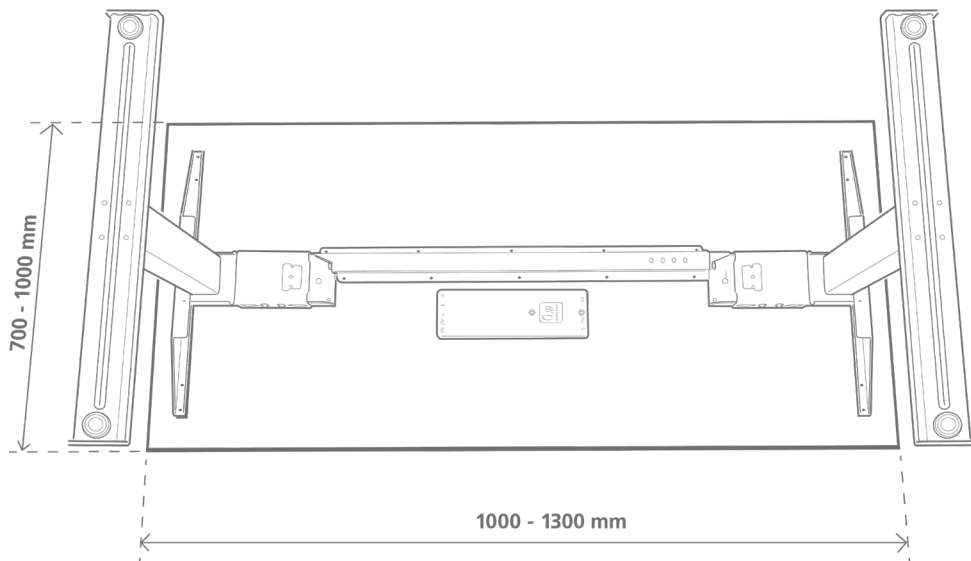

Kick & Click Adjustable (compact) and control box mounted on the tabletop (cantilevers centrally placed)



Recommended tabletop

Material	Veneered chipboard Plywood
Thickness	Min 21 mm (13/16")
Size	Min. 700 x 1000 mm (27" x 39.5") Max. 1000 x 1300 mm (39" x 51")

Assembling the Kick & Click system

Kick & Click Adjustable

1. Gather all parts for the desk.

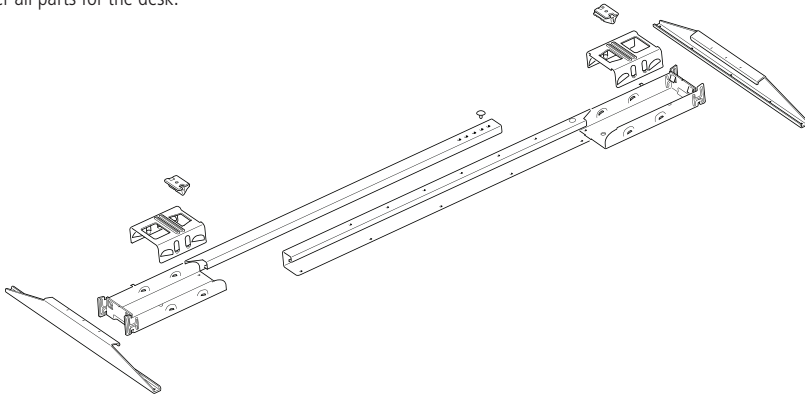

2. Fix the inner rail with the outer rail (only Kick & Click Adjustable).

2.1. Extend the rails to the required length (frame width from 1140 to 1940 mm) using the holes on the rails as a length indicator.

2.2. Fix the length with the clip.

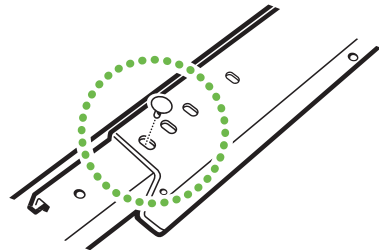
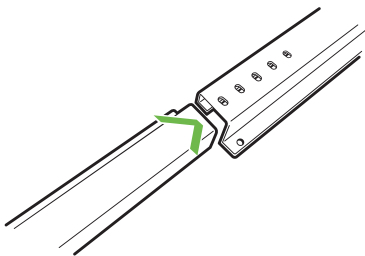

3. Slide the cantilevers onto the base of the inner and outer rails.

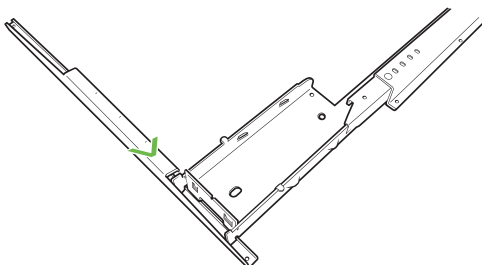

4. Align the cantilever

T-desk

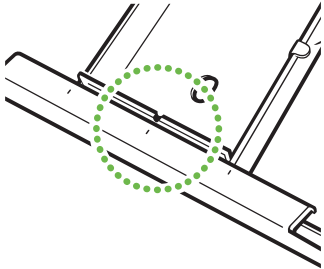

Align the middle marker on the cantilever with the centre on the inner rail/outer rail

C-desk

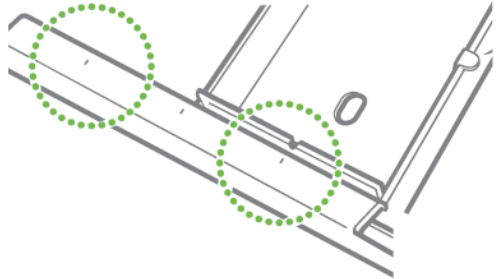

Outer markers on the cantilever indicate 50 mm maximum displacement from the centre on the inner rail/outer rail

5. Mount the column by placing it in the base.

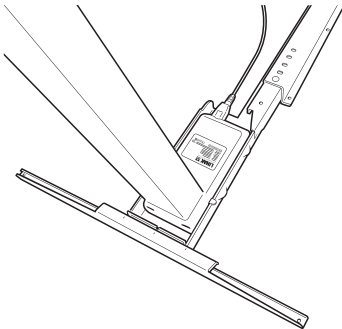

The Column is prepared for Kick & Click™ with slots on the backside of the housing (see drawings)

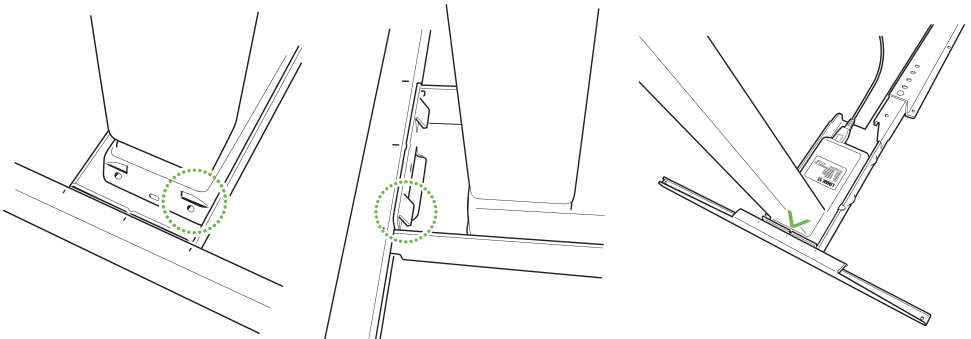

6. Place the clamp on the column housing, press it down gently. It will still be possible to move clamp a little when placed.

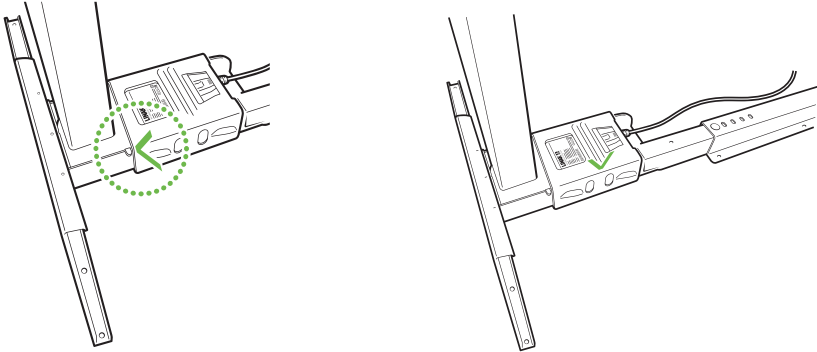

7. Place the Kick Lock in the clamp. The arrow on the Kick Lock must face the arrow on the clamp.

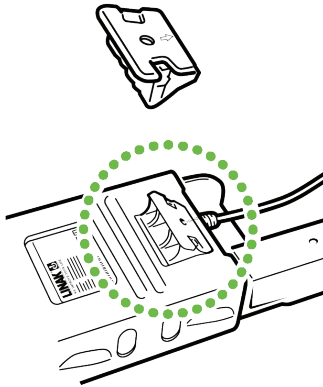

8. Fix the Kick Lock in the clamp with your foot. When you hear a “click”, the Kick Lock is mounted and the column is fixed to the Kick & Click parts.
Repeat the mounting in the other end.

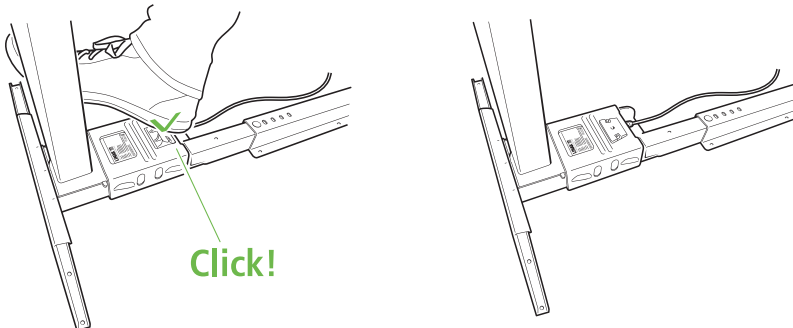

Assembling a three-legged desk

The 3rd leg kit has only one base which is welded onto the outer rail.

Mount the Kick & Click Adjustable system as described above.

1. Gather all 3rd leg kit system parts.

2. Fix the inner rail with the outer rail.

2.1. Extend the rails to the required length (frame width from 1100 to 1700 mm) using the holes on the rails as a length indicator.

2.2. Fix the length using the clip.

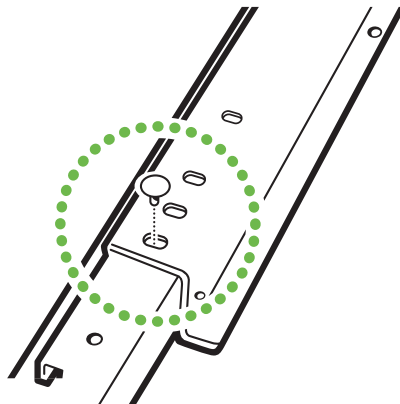
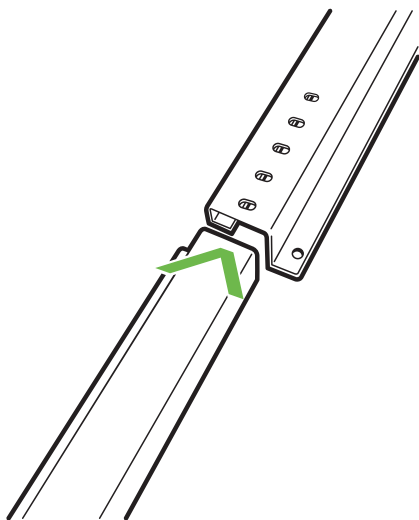

3. Finish mounting the Kick & Click 3rd leg kit following the same procedure as in Assembling Kick & Click system, steps 3 to 8.

Example of Kick & Click three-legged desk

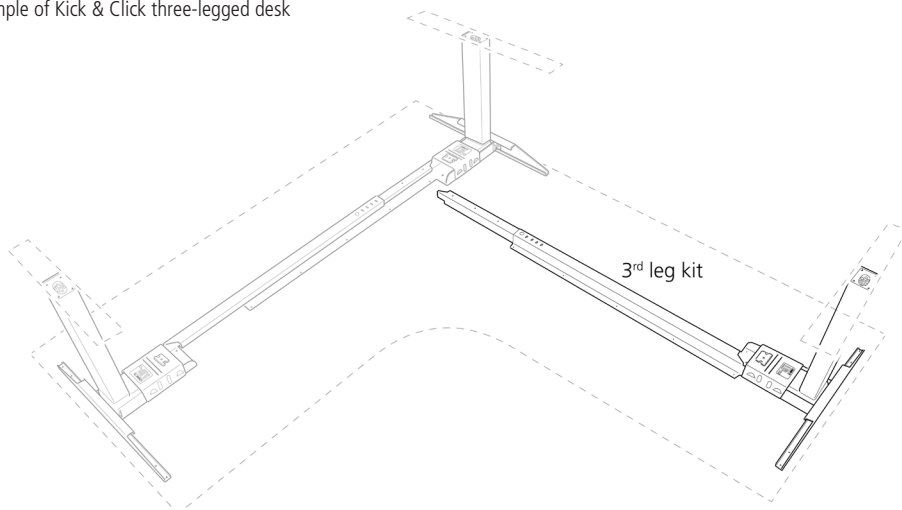

Mounting the tabletop

The oval holes in the inner and outer rails and in the cantilevers of the Kick & Click system facilitate mounting of tabletops with pre-drilled holes.



Old Kick & Click versions with circular holes

Do **not** pre-drill holes for all the parts.

The combination of hole tolerances on each part, e.g. cantilever and rail, will cause uncertainty about the overall tolerances on the assembled Kick Click system. Therefore, we recommend drilling the holes when the assembled frame is mounted to the tabletop.

Exceptions:

- Fixing the Kick & Click Adjustable to a tabletop

With a Kick & Click Adjustable system, a customer can pre-drill the holes for the cantilevers to fix the system to the tabletop. This can be done because the rails are adjustable. The hole size is $5.3 \pm 0,2$ mm and the tolerances on the distance between the holes are ± 0.2 mm.

- Fixing the Kick & Click Fixed to a tabletop

With a Kick & Click Fixed system, a customer can pre-drill the holes for the rail to fix the system to the tabletop. The hole size is 5.3 ± 0.2 mm and the tolerances on the distance between the holes are ± 0.5 mm.



Max. distance from the centre of the base to edge of the tabletop: 550 mm

Max. distance from the centre of the base to centre of the cantilever: 50 mm

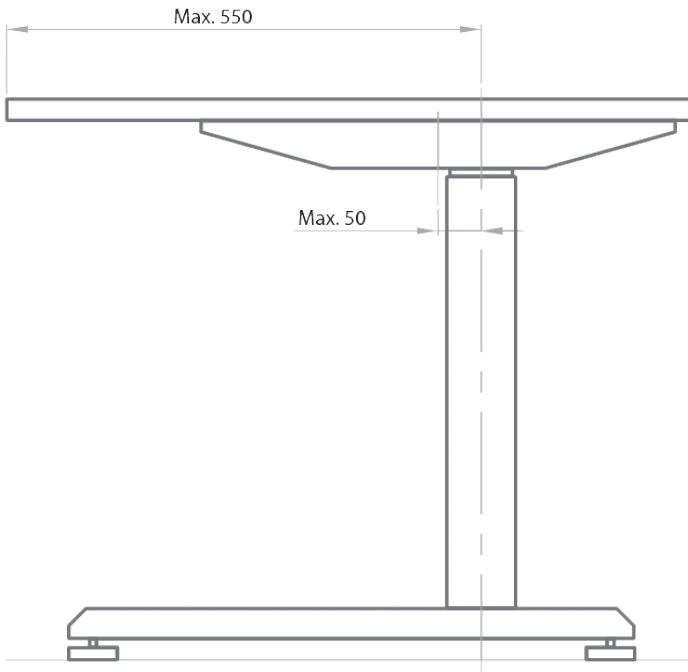
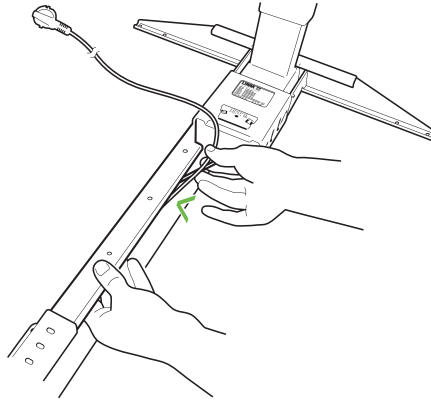
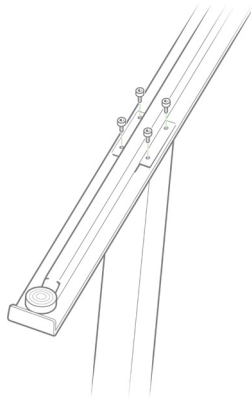

Figure 9 Kick & Click tabletop alignment measurements in mm

1. Turn the tabletop upside down.
2. Place the assembled Kick & Click in the preferred position.
3. Mark and pre-drill holes in the tabletop, if not done yet.
4. Fasten the Kick & Click to the tabletop with screws (in inner/outer rails and cantilevers).
5. Mount and connect the electronics (see instructions below).
6. Hide the cables. The rails are designed so cables from the columns and the control box can be hidden inside the rail.



7. Mount the feet on the columns using eight M6 mounting screws.



8. Mount the adjustment screws.

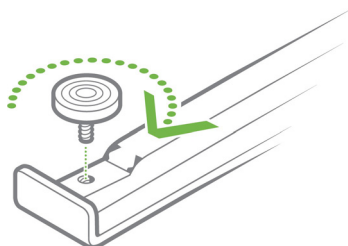

Disassembly

A disassembling instruction video is available [here](#).

Disassembling Kick & Click.

1. Remove the Kick Lock.

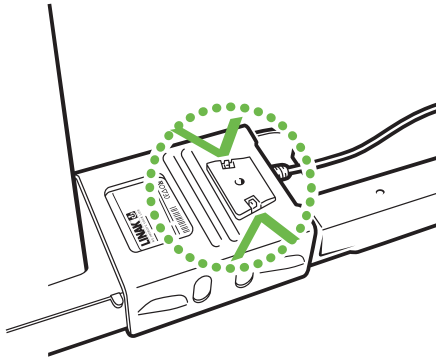

Gently press the two pins on the side of the Kick Lock

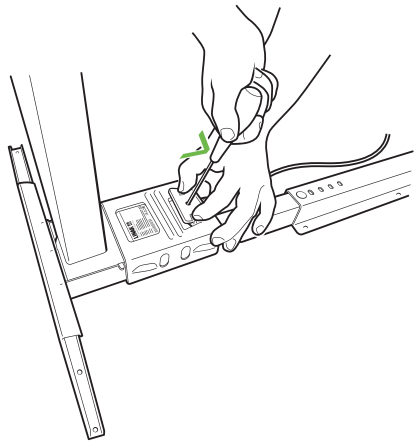

Keep pressing while removing the Kick Lock using a screwdriver

2. Gently hit the end of the clamp to loosen it, e.g. using screwdriver handle

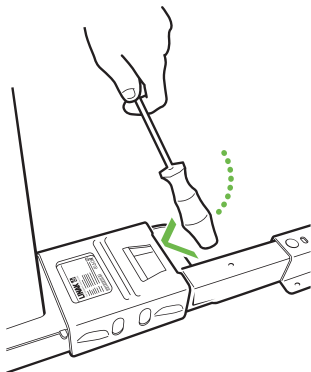

3. Place the screwdriver in one of the holes on the clamp and twist it a bit until the clamp is released from the base part.

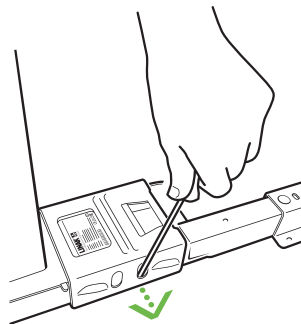

4. Remove the clamp.

5. Disassemble the rest of the system.

Accessories

Ordering accessories

Order from your nearest LINAK® contact, distributor or subsidiary.

Accessories

Please contact your nearest LINAK® contact, distributor or subsidiary.



Warning!

By unauthorised opening of the system there is a risk that it may malfunction at a later date.

Spare parts

Please contact your nearest LINAK contact for information on spare parts.

Disposal of LINAK product

As LINAK's customers often ask us how our products can be disposed or scrapped we have prepared this guide that enables a classification to different waste fractions for recycling or combustion.

Guide

We recommend our products to be disassembled as much as possible and divided into different waste groups for recycling or combustion.

For example, waste can be sorted into metals, plastics, cable scrap, combustible material, and recoverable resources.

Some of these main groups can be further divided into subgroups; e.g. metal can be divided into steel/aluminium/copper and plastic can be divided into ABS/PA/PE/PP.

As an example, the table below breaks down the different components in LINAK products to various recycling groups:

Product	Components	Recycling group
Columns/ Actuator :	Spindle and motor Plastic housing Cable PCB boards	Scrap Plastic recycling or combustion Cable scrap or combustion Electronics scrap
Control Box :	PCB boards Plastic housing Cable Transformer	Electronics scrap Plastic recycling or combustion Cable scrap or combustion Metal scrap
Handset/Control :	Plastic housing Cable PCB board	Plastic recycling or combustion Cable scrap or combustion Electronics scrap
Kick & Click	Metal parts	Scrap

By now almost all our casted plastic parts are supplied with an interior code for plastic type and fibre content, if any.

Main groups of disposal

Product main groups	Metal scrap	Cable scrap	Electronics scrap	Plastic recycling or combustion	Comments
Kick & Click™ cantilever	X				
Kick & Click™ inner + outer rail	X				
Kick & Click™ clamp	X				
Kick & Click™ kick lock				X	
Kick & Click™ clips				X	
DESKLIFT™ Feet	X			X	

Kick & Click Adjustable (compact)

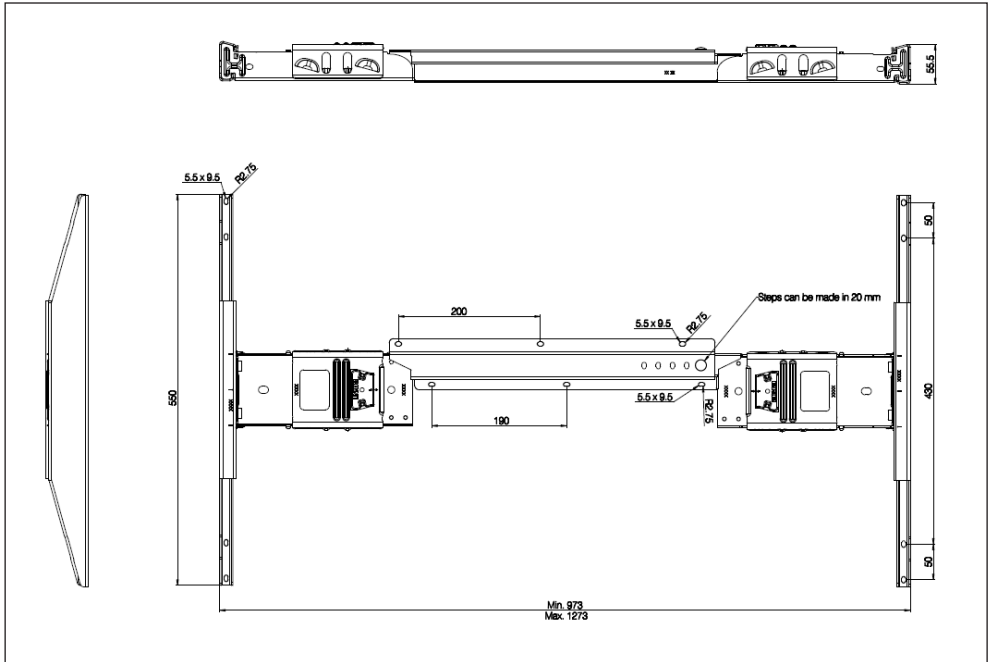

Kick & Click Base

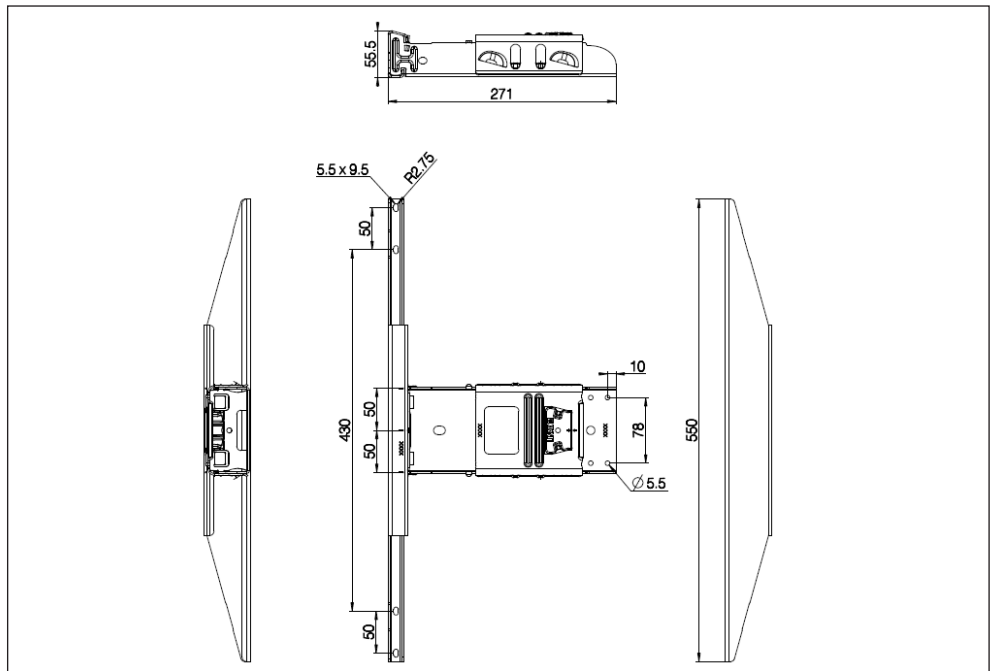

DL5/DL6 on top mounted column, 560 mm

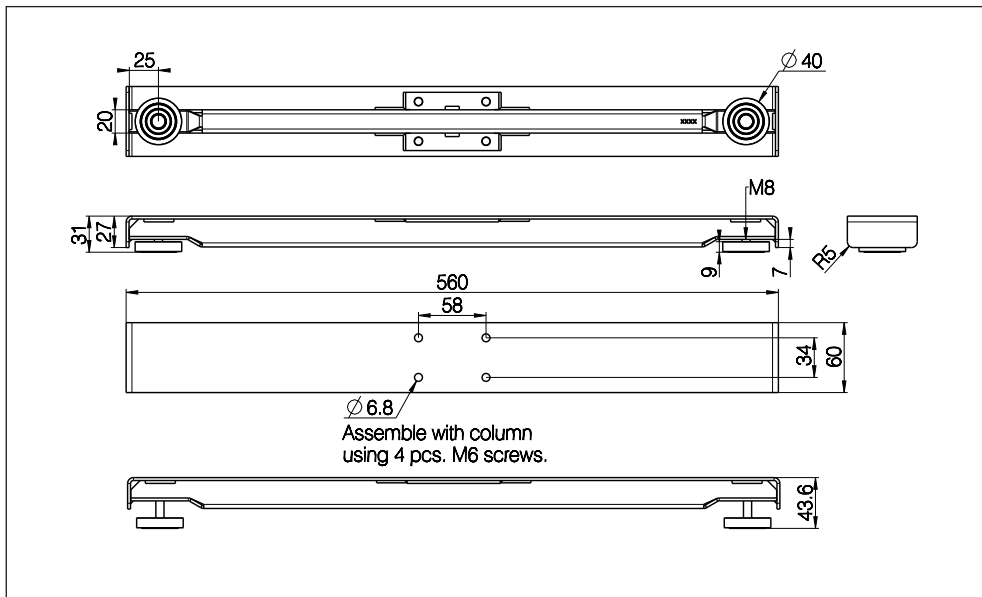

DL5/DL6 on top mounted column, 710 mm

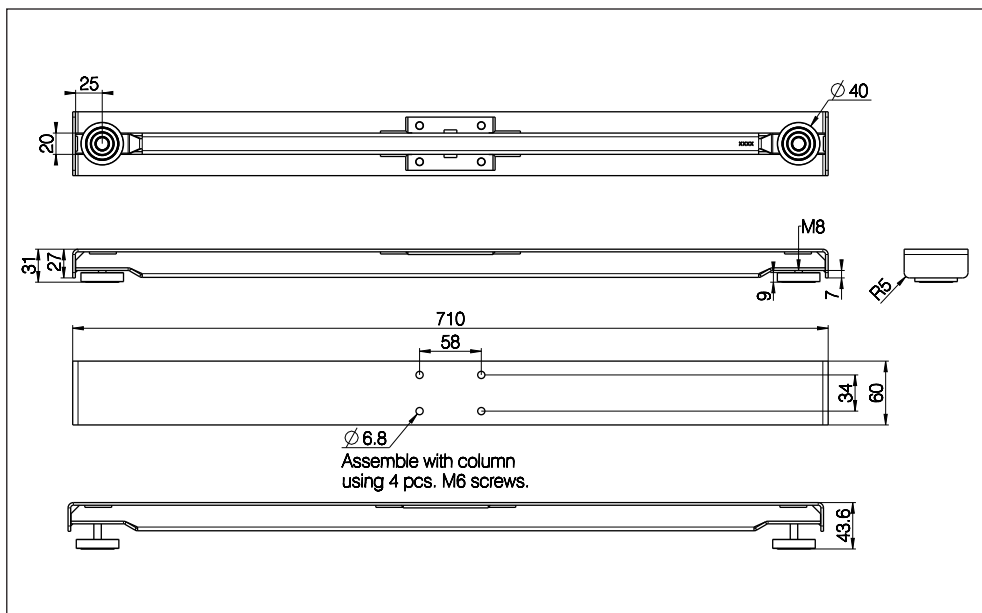

DL10/DL11/DL14/DL17/DL19 on top mounted column, 560 mm

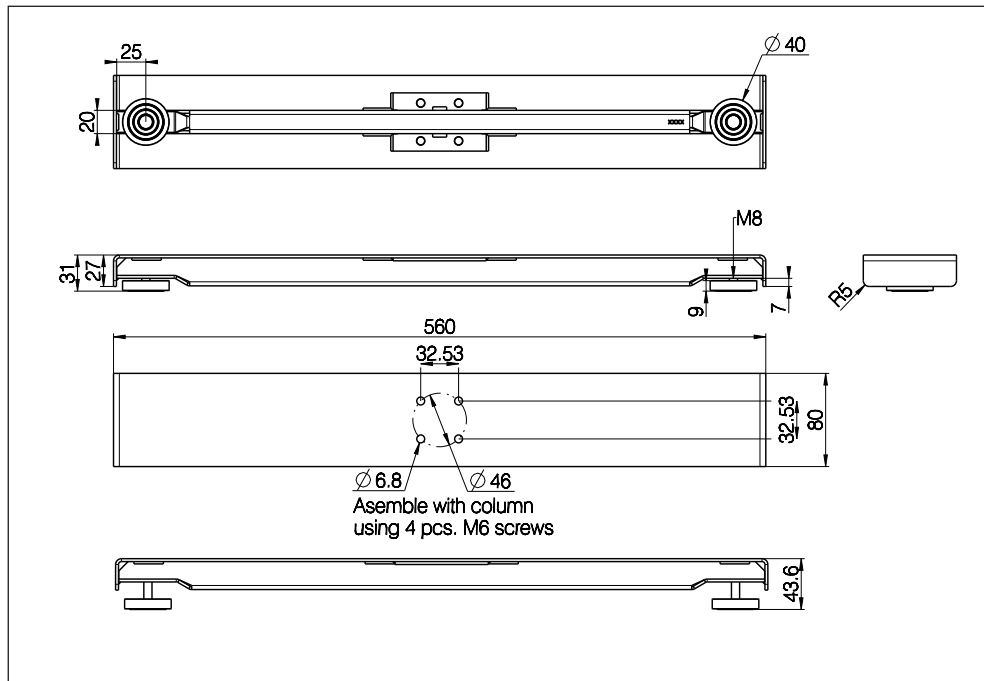

DL10/DL11/DL14/DL17/DL19 on top mounted column, 710 mm

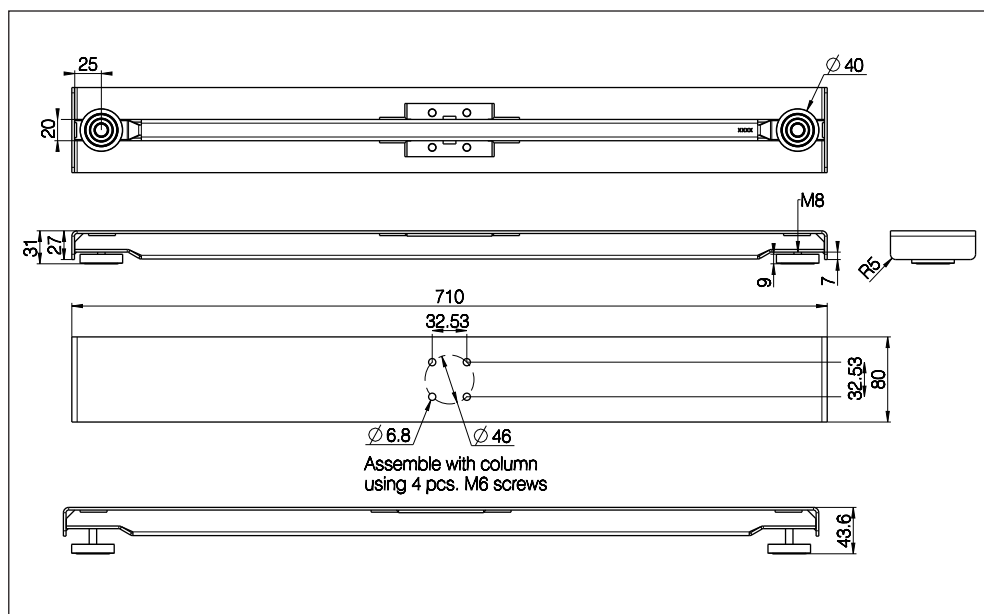

DL17/DL18/DL19 recessed mounted column, 560 mm

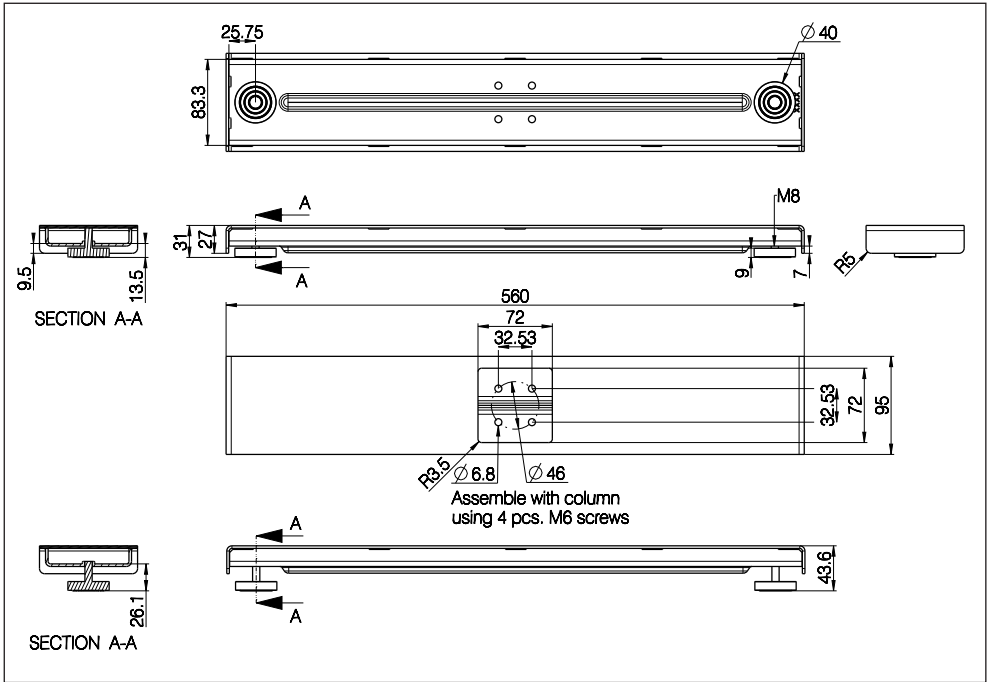

DL17/DL18/DL19 recessed mounted column, 710 mm

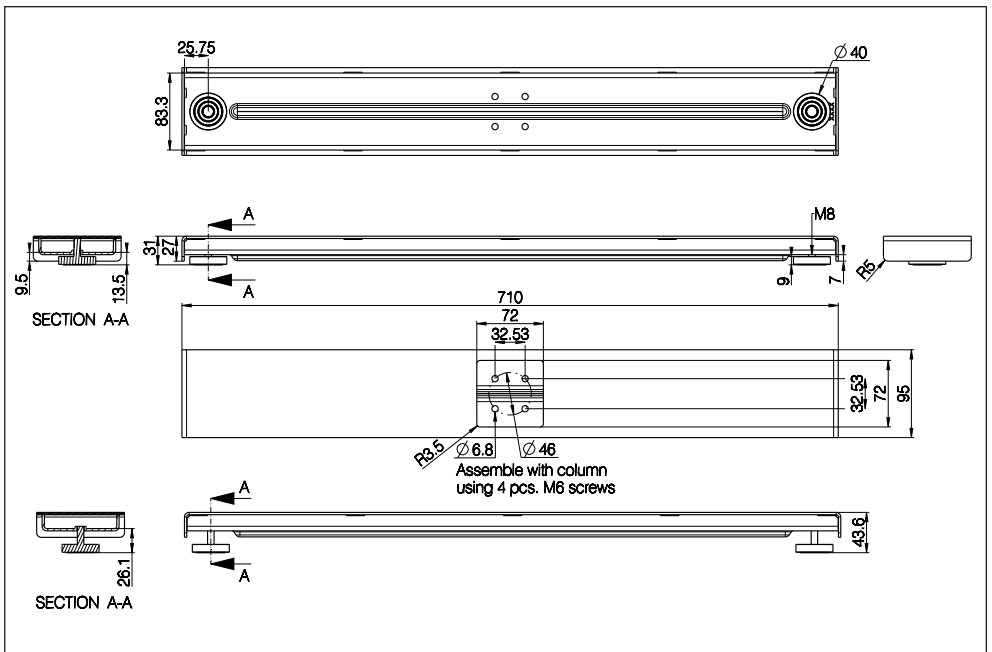

LINAK APPLICATION POLICY

The purpose of the application policy is to define areas of responsibilities in relation to applying a LINAK product defined as hardware, software, technical advice, etc. related to an existing or new customer application.

LINAK products, as defined above, are applicable for a wide range of applications within the Medical, Furniture, Desk and Industry areas. Yet, LINAK cannot know all the conditions under which LINAK products will be installed, used, and operated, as each individual application is unique.

The suitability and functionality of the LINAK product and its performance under varying conditions (application, vibration, load, humidity, temperature, frequency, etc.) can only be verified by testing, and shall ultimately be the responsibility of the LINAK customer using any LINAK product.

LINAK shall be responsible solely that the LINAK products comply with the specifications set out by LINAK and it shall be the responsibility of the LINAK customer to ensure that the specific LINAK product can be used for the application in question.

FACTORIES

China

LINAK (Shenzhen) Actuator Systems, Ltd.
Phone: +86 755 8610 6656
Phone: +86 755 8610 6990
www.linak.cn

Denmark - Headquarters

LINAK A/S
Phone: +45 73 15 15 15
Fax: +45 74 45 80 48
Fax (Sales): +45 73 15 16 13
www.linak.com

Slovakia

LINAK Slovakia s.r.o.
Phone: +421 51 7563 444
www.linak.sk

Thailand

LINAK APAC Ltd.
Phone: +66 33 265 400
www.linak.com

USA

LINAK U.S. Inc.
Americas Headquarters
Phone: +1 502 253 5595
Fax: +1 502 253 5596
www.linak-us.com
www.linak-latinamerica.com

SUBSIDIARIES

Australia

LINAK Australia Pty. Ltd
Phone: +61 3 8796 9777
Fax: +61 3 8796 9778
www.linak.com.au

Austria

LINAK Repräsentanz - Österreich (Wien)
Phone: +43 (1) 890 7446
Fax: +43 (1) 890 744615
www.linak.at - www.linak.hu

Belgium

LINAK Actuator-Systems NV/SA
(Belgium & Luxembourg)
Phone: +32 (0)9 230 01 09
www.linak.be - www.fr.linak.be

Brazil

LINAK Do Brasil Comércio De Atuadores Ltda.
Phone: +55 (11) 2832 7070
Fax: +55 (11) 2832 7060
www.linak.com.br

Canada

LINAK Canada Inc.
Phone: +1 502 253 5595
Fax: +1 416 255 7720
www.linak-us.com

Czech Republic

LINAK C&S s.r.o.
Phone: +42 058 174 1814
Fax: +42 058 170 2452
www.linak.cz - www.linak.sk

Denmark - International

LINAK - International
Phone: +45 73 15 15 15
www.linak.com

Denmark - Sales

LINAK DANMARK A/S
Phone: +45 86 80 36 11
Fax: +45 86 82 90 51
www.linak.dk

Finland

LINAK OY
Phone: +358 10 841 8700
www.linak.fi

France

LINAK FRANCE E.U.R.L.
Phone: +33 (0) 2 41 36 34 34
Fax: +33 (0) 2 41 36 35 00
www.linak.fr

Germany

LINAK GmbH
Phone: +49 6043 9655 0
Fax: +49 6043 9655 60
www.linak.de

India

LINAK A/S India Liaison Office
Phone: +91 120 4531797
Fax: +91 120 4786428
www.linak.in

Ireland

LINAK UK Limited (Ireland)
Phone: +44 (0)121 544 2211
Fax: +44 (0)121 544 2552
+44 (0)796 855 1606 (UK Mobile)
+35 387 634 6554
(Republic of Ireland Mobile)
www.linak.co.uk

Italy

LINAK ITALIA S.r.l.
Phone: +39 02 48 46 33 66
Fax: +39 02 48 46 82 52
www.linak.it

Japan

LINAK K.K.
Phone: 81-45-533-0802
Fax: 81-45-533-0803
www.linak.jp

Malaysia

LINAK Actuators Sdn. Bhd.
Phone: +60 4 210 6500
Fax: +60 4 226 8901
www.linak.my

Netherlands

LINAK Actuator-Systems B.V.
Phone: +31 76 5 42 44 40
www.linak.nl

New Zealand

LINAK New Zealand Ltd
Phone: +64 9580 2071
Fax: +64 9580 2072
www.linak.com.au

Norway

LINAK Norge AS
Phone: +47 32 82 90 90
www.linak.no

Poland

LINAK Polska
LINAK Danmark A/S (Spółka Akcyjna)
Phone: +48 22 295 09 70 /
+48 22 295 09 71
www.linak.pl

Republic of Korea

LINAK Korea Ltd.
Phone: +82 2 6231 1515
Fax: +82 2 6231 1516
www.linak.kr

Spain

LINAK Actuadores, S.L.u
Phone: +34 93 588 27 77
Fax: +34 93 588 27 85
www.linak.es

Sweden

LINAK Scandinavia AB
Phone: +46 8 732 20 00
Fax: +46 8 732 20 50
www.linak.se

Switzerland

LINAK AG
Phone: +41 43 388 31 88
Fax: +41 43 388 31 87
www.linak.ch - www.fr.linak.ch
www.it.linak.ch

Taiwan

LINAK (Shenzhen) Actuator systems Ltd.
Taiwan Representative office
Phone: +886 2 272 90068
Fax: +886 2 272 90096
www.linak.tw

Turkey

LINAK İth. İhr. San. ve Tic. A.Ş.
Phone: +90 312 4726338
Fax: +90 312 4726635
www.linak.com.tr

United Kingdom

LINAK UK Limited
Phone: +44 (0)121 544 2211
Fax: +44 (0)121 544 2552
www.linak.co.uk

DISTRIBUTORS

Argentina

NOVOTEC ARGENTINA SRL
Phone: 011-4303-8989/8900
Fax: 011-4032-0184
www.novotecargentina.com

Colombia

MEM Ltda
Phone: +[57] (1) 334-7666
Fax: +[57] (1) 282-1684
www.mem.net.co

India

Mechatronics Control Equipments
India Pvt Ltd
Phone: +91-44-28558484, 85
www.mechatronicscontrol.com

Indonesia

PT. HIMALAYA EVEREST JAYA
Phone: +6 221 544 8956,
+6 221 544 8965
Fax: +6 221 619 1925
Fax (Sales): +6 221 619 4658
www.hej.co.id

Iraq

Scan Medical Tech
Phone: +964 770 470 2202

Israel

NetivTech LTD
Phone: +972 55-2266-535
Fax: +972 2-9900-560
www.netivtech.com

Kingdom of Bahrain

Mechatronics Industrial Equipments
Phone: +973 17280059
Fax: +973 17910045
www.mechatronicsbh.com

Qatar

Mechatronics Industrial Equipments
Phone: +974 44581155
Fax: +974 44689135
www.mechatronicsqatar.com

Singapore

Servo Dynamics Pte Ltd
Phone: +65 6844 0288
Fax (Sales): +65 6844 0070

South Africa

Industrial Specialised Applications CC
Phone: +27 011 466 0346
www.isaza.co.za

United Arab Emirates

Mechatronics Industrial Equipments LLC
Phone: +971 4 267 4311
Fax: +971 4 267 4312
www.mechatronics.ae

LINAK® accepts no responsibility for possible errors or inaccuracies in catalogues, brochures, and other material. LINAK reserves the right to change its products without prior notice. LINAK cannot guarantee product availability and reserves the right to discontinue the sale of any product. The user is responsible for determining the suitability of LINAK products for a specific application. All sales are subject to the 'Standard Terms of Sale and Delivery', available on LINAK websites.

LINAK and the LINAK logotype are registered trademarks of LINAK A/S. All rights reserved.



WE IMPROVE YOUR LIFE