

Linear Actuator LA36

User Manual



Contents

Preface	4
Terms of use	5
Introduction	6
Safety instructions	6
Warning	7
Features	8
Options in general	9
Usage	10
B10 Lifetime calculation	11
Fixed load	11
Varying load	11
B10 Lifetime prediction	12
12 V DC	12
24/48 V DC	13
Intermittence	14
Speed and current curves:	15
Mounting guidelines	19
Stroke and built-in tolerances	21
Built-in dimensions	22
Electrical installation	23
The current limiting algorithm	24
Current limits	25
Max. Current	25
Current cut-offs	26
Mounting of cables	27
Mounting of cable with Off-highway	28
Off-highway connection to Actuator Connect™	28
Manual hand crank:	29
Label for LA36	30
Maintenance	31
Repair	31
Main groups of disposal	31
Warranty	31
Maintenance	32
Repair	32
Main groups of disposal	32
Warranty	32
Declaration of Conformity	33

Declaration of incorporation of partly completed machinery.....	40
ATEX/IECEX/CCC certified.....	41
Warning	42
Max fuse for ATEX/IECEX/CCC actuators	43
Mounting and replacement of ATEX cables.....	44
Replacing an ATEX cable.....	45
Contacts.....	66

Preface

Dear User,

We are delighted that you have chosen a LINAK® product.

LINAK systems are high-tech products based on many years of experience in the manufacture and development of actuators, lifting columns, desk frames, electric control boxes, controls, batteries, accessories and chargers.

This User Manual does not address the end user. It is intended as a source of information for the equipment or system manufacturer only, and it will tell you how to install, use and maintain your LINAK electronics. The manufacturer of the end product has the responsibility to provide a User Manual, where relevant safety information from this manual is passed on to the end user.

We are convinced that your LINAK product/system will give you many years of problem-free operation.

Before our products leave the factory, they undergo both function and quality testing. Should you, nevertheless, experience problems with your product/system, you are always welcome to contact your supplier.

LINAK subsidiaries and some distributors situated all over the world have authorised service centres, which are always ready to help you. Locate your local contact information on the back page.

LINAK provides a warranty on all products. (See warranty section).

This warranty, however, is subject to correct use in accordance with the specifications, maintenance being done correctly, and any repairs being carried out at a service centre, which is authorised to repair LINAK products.

Changes in installation and use of LINAK systems can affect their operation and durability. The products may only be opened by authorised personnel.

This User Manual has been written based on the present technical knowledge. LINAK reserves the right to carry out technical modifications and keeps the associated information updated.

LINAK A/S

Terms of use

LINAK® takes great care in providing accurate and up-to-date information on its products. However, the user is responsible for determining the suitability of LINAK products for a specific application.

Due to continual development, LINAK products are subject to frequent modifications and changes. LINAK reserves the rights to conduct modifications, updates, and changes without any prior notice. For the same reason, LINAK cannot guarantee the correctness and actual status of imprinted information on its products.

LINAK uses its best efforts to fulfil orders. However, for the reasons mentioned above, LINAK cannot guarantee availability of any particular product at any given time. LINAK reserves the right to discontinue the sale of any product displayed on its website or listed in its catalogues or in other written material created and produced by LINAK, LINAK subsidiaries, or LINAK affiliates.

All sales are subject to the 'Standard Terms of Sale and Delivery for LINAK A/S' available on LINAK websites.

LINAK and the LINAK logotype are registered trademarks of LINAK A/S. All rights reserved.

Introduction

Extremely powerful linear actuator made by LINAK. Up to 6,800 N thrust, or up to 168 mm/s. Designed to operate in extreme conditions. Solid choice for industrial and agricultural applications.

Safety instructions

Please read this safety information carefully.

Be aware of the following three symbols throughout the document:



Warning!

Failing to follow these instructions can cause accidents resulting in serious personal injury.



Recommendations

Failing to follow these instructions can result in the actuator suffering damage or being ruined.



Additional information

Usage tips or additional information that is important in connection with the use of the actuator.

Furthermore, ensure that all staff who are to connect, mount, or use the actuator are in possession of the necessary information and that they have access to this user manual.

Persons who do not have the necessary experience or knowledge of the product/products must not use the product/products. Besides, persons with reduced physical or mental abilities must not use the product/products, unless they are under surveillance or they have been thoroughly instructed in the use of the apparatus by a person who is responsible for the safety of these persons.

Moreover, children must be under surveillance to ensure that they do not play with the product.

Before you start mounting/dismounting, ensure that the following points are observed:

- The actuator is not in operation.
- The actuator is free from loads that could be released during this work.

Before you put the actuator into operation, check the following:

- The actuator is correctly mounted as indicated in the relevant user instructions.
- The equipment can be freely moved over the actuator's whole working area.
- The actuator is connected to a mains electricity supply/transformer with the correct voltage and which is dimensioned and adapted to the actuator in question.
- Ensure that the voltage applied matches to the voltage specified on the actuator label.
- Ensure that the connection bolts can withstand the wear.
- Ensure that the connection bolts are secured safely.

During operation, please be aware of the following:

- Listen for unusual sounds and watch out for uneven running. Stop the actuator immediately if anything unusual is observed.
- Only use the actuator within the specified working limits.
- Do not step on or kick the actuator.

When the equipment is not in use:

- Switch off the mains supply in order to prevent unintentional operation.
- Check regularly for extraordinary wear.

Classification

The equipment is not suitable for use in the presence of a flammable anaesthetic mixture with air or with oxygen or nitrous oxide.

**Warnings**

- Do not sideload the actuator.
- When mounting the actuator in the application ensure that the bolts can withstand the wear and that they are secured safely.
- If irregularities are observed, the actuator must be replaced.
- The standard actuator (without Integrated Controller) without clutch, is not allowed to run into a mechanical block -before reaching the end of stroke.

**Recommendations**

- Do not place load on the actuator housing.
- Prevent impact or blows, or any other form of stress to the housing.
- Ensure that the cable cover is mounted correctly. Use 3.5 Nm torque.
- Ensure that the duty cycle and the usage temperatures for LA36 actuators are respected.
- Ensure that the cable cannot be squeezed, pulled or subjected to any other stress.
- Furthermore, it will be good practice to ensure that the actuator is fully retracted in the “normal” position. The reason is that there will be a negative pressure inside the actuator if it is extended which over time can lead to water entering the actuator.

**Warning**

This ATEX User Manual is an appendix to the Product User Manual - applicable for ATEX/IECEX/CCC approved actuators only. All information not regarded to ATEX/IECEX/CCC will be found in the Product User Manual.

If there should be any differences between the Product User Manual and this document, regarding to ATEX, -this document is valid.

Note that this product is NOT to be used within flammable gas filled environments.

Features

- 12, 24, 36 or 48 V DC permanent magnetic motor (IC only 12/24/48 V DC)
- Load from 500 N - 6.800 (depending on gear ratio and spindle pitch)
- Max. speed 168 mm/sec. (depending on gear ratio and spindle pitch)
- Stroke length from 25 to 1200 mm (with Integrated Controller from 75 to 1200 mm)
- Built-in endstops reached function
- Highly efficient acme thread spindle
- Safety factor 2: The actuator has been certified to withstand static loads that are twice the magnitude of its dynamic load capacity without sustaining damage.
- Heavy duty aluminium housing for harsh conditions
- Protection class: IP66 for outdoor use (dynamic). Furthermore, the actuator can be washed down by a high pressure cleaner (IP69K - static)
- Hand crank for manual operation
- Integrated brake with high self-lock ability
- Endplay: see [Technical Specifications](#)
- Non-rotating piston rod eye
- Noise level: 76 dB (A). Measuring method: DS/EN ISO 3746 (actuator not loaded)
- Weight: 4.55 kg for 100 mm stroke; additional 0.24 kg for each additional 50mm stroke (Cable not included; weight varies by selected options)
- Off-highway Features:
 - 12 or 24 V DC brushed permanent magnetic motor
 - Load from 1,700 N - 6,800 N (depending on gear ratio and spindle pitch)
 - Max. speed 7 mm/sec. to 100 mm/sec. (depending on gear ratio and spindle pitch)
 - Reinforced aluminium housing for harsh conditions
 - IPC-A-610 Class 3 (High-performance electronic products)
 - IP54 without cable mounted
IP69K (static) with cable mounted with shell or moulded cable
 - Connector plug type: DT16-18SA-K004, AT16-18SA-K004 or TE 2600047-1

An Off-highway vehicle is intended for use on steep or uneven ground and includes those used for construction or agriculture. They are specifically designed for off-road use.

Quad bikes, dirt bikes, dune buggies and other types of all-terrain vehicles are also types of Off-highway vehicles, although their function is very different from motor vehicles designed for industrial and farming use.

Options in general

- Back fixture can be ordered in steps of 30 degrees
- Exchangeable cables in different lengths
- Hall effect sensor
- Analogue or digital feedback for precise positioning
- Endstop reached signals
- Mechanical overload protection through integrated slip clutch -Standard actuators only
- Mechanical potentiometer (not applicable with IC)
- When ordering AISI (304 and up) piston rod eye and back fixture, stainless steel screws are automatically included
- Special anodised housing for extreme environments -see paragraph regarding 'Special anodised housing'
- Adjustable magnetic sensors for endstop signals (code no. 1017031)
- IC options including:
 - I/O
 - Ethernet/IP
 - Modbus TCP/IP
 - Modbus RTU
 - PROFINET
 - IO-Link
 - LIN bus
 - CAN SAE J1939
 - CANopen
 - Off-highway LIN bus
 - Off-highway CAN SAE J1939
 - Off-highway CANopen

See specific interface user manuals at the [TECHLINE webpage](#) for Connection Diagrams and I/O specifications

- PC configuration tool (BusLink or Actuator Connect™)
- ATEX/IECEX/CCC (Ex) certified for Zone 21 (Not applicable for Off-highway actuators)

Usage

- Duty cycle at full load up to 600 mm stroke: max. 20% (240 s drive and 960 s rest)
- Duty cycle at full load for 601-999 mm : max. 15% (180 s drive and 1020 s rest)
- Duty cycle at full load for 1000-1200 mm stroke: max. 10% (120 s drive and 1080 s rest)

These duty cycles are specified for an ambient temperature of 40 °C.

Variations in load or ambient temperature will change the actual duty cycle values.

The maximum run time of the actuator must be determined based on an overall cycle time of 20 minutes or less.

- Ambient operating temperature: Full performance from +5°C to +40°C
-30°C (reduced load 50%) to +85°C (reduced duty cycle 10%)
-40°C (no load)
- Ambient operating temperature for ATEX/IECEX/CCC: -25°C to +65°C
- Storage temperature: -40 °C to +70 °C
Actuator is not activated/
connected
-40°C to +85°C for 72 hours
-55°C to +95°C for 24 hours for Standard platform
-55°C to +105°C for 24 hours for Integrated Control platform
Acclimatization before usage.
- Relative humidity: Full performance from 20 % to 80 % - non-condensing
(Actuator is neither activated nor connected)
- Cyclic state: 93 % to 98 % - non-condensing +25°C to +55°C for 12 hours
- Steady state 93 % to 95 % - non-condensing +40°C for 56 days
- Atmospheric pressure: 700 to 1060 hPa
- Meters above sea level: Max. 3000 meters
 - For applications operated at constantly low temperatures it might be beneficial to recommend a stronger version of the actuator to reduce the current consumption that in some combinations can be up to 3 times higher (at -40° Celsius)
- Off-highway:
 - Tested according to: ISO14982-1 / Agricultural and forestry machinery - Electromagnetic compatibility - Part 1: General EMC requirements (clamped capacitor circuit)
 - Compliant with: ROHS2 : 2011/65/EU: Directive on the restriction of the use of certain hazardous substances in electrical and electronic equipment EMC Directive - 2014/30/EU

B10 Lifetime calculation

The lifetime of LINAK® actuators has been tested and estimated according to the B10 standard, which is useful both in terms of maintenance and choice of actuator. The B10 metric describes that at least 90% of the products purchased will meet or exceed lifetime expectations when used and maintained correctly. On the other hand, 10% might fail to meet this prediction.

In our actuators, the B10 lifetime is calculated based on the first failure which causes the actuator to stop working. The test was conducted with three groups of actuators, where the first group carried a 100% load, the second carried a 50% load, and the third carried a 25% load. This provided a reliable estimation of lifetime.

LINAK actuators can be utilised with either a fixed or a varying load, and lifetime can be calculated for both. A converter for the LA36 can be found [here](#). The lifetime can be calculated for other actuators using the following methods:

Fixed load

The lifetime of an actuator with a fixed load can be found in the curves on the next pages. Simply find the load of the particular actuator on the X-axis and locate where it intersects with the estimated lifetime on the Y-axis.

Example given:

A 12 V 6.800 N LA36 with a load of 3.000 N will have an estimated lifetime of 30 km.

Varying load

As opposed to a fixed load, a varying load changes during the working cycle. Therefore, an equivalent load must be calculated using this formula:

$$F_{eq} = \sqrt[2]{\frac{(L1 * F1^2) + (L2 * F2^2) + \dots (Ln * Fn^2)}{L}}$$

Essentially, the stroke length must be divided into as many sections of different loads as necessary, denominated Ln and Fn. For example, the first 50 mm could have a 6.800 N load, the next 100 mm a 4.900 N load, and the last 120 mm a 2.000 N load. These numbers squared must then be divided by the full stroke length called L. For an actuator with these loads and a stroke length of 270 mm, the equation then becomes this:

$$F_{eq} = \sqrt[2]{\frac{(50 * 6.800^2) + (100 * 4.900^2) + (120 * 2.000^2)}{270}} = 4.386 \text{ N}$$

Now this load can be used on the following pages for an estimated lifetime.



External factors including temperature, vibrations, and humidity can influence the lifetime of an actuator.

If you wish to convert the lifetime kilometers to cycles, you need to multiply these with a million and divide it with two times the stroke length in mm. For a 12 V 6.800 N LA36 with a stroke length of 100 mm, these would be the calculations:

$$\frac{30 \text{ Km} * 1.000.000}{2 * 100} = 150.000 \text{ cycles}$$

B10 Lifetime prediction

12 V DC

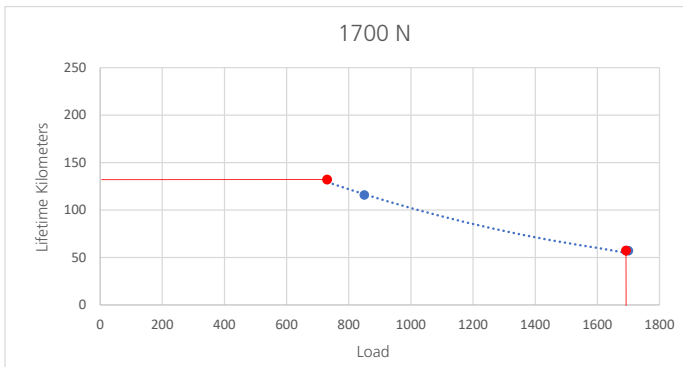
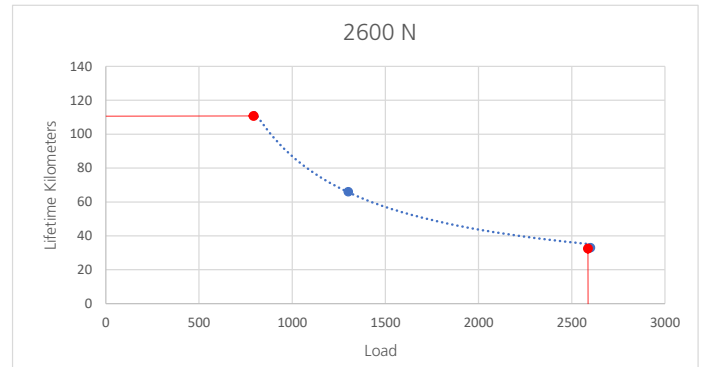
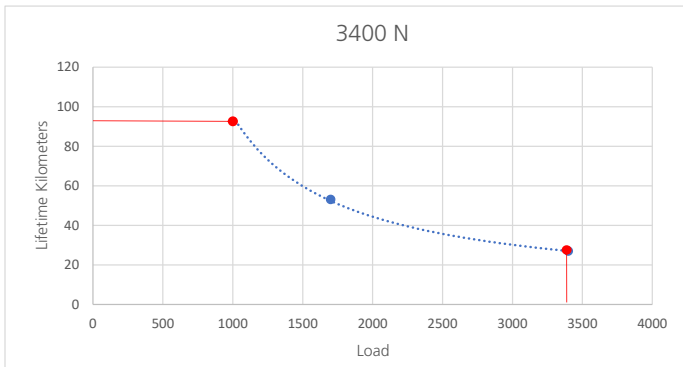
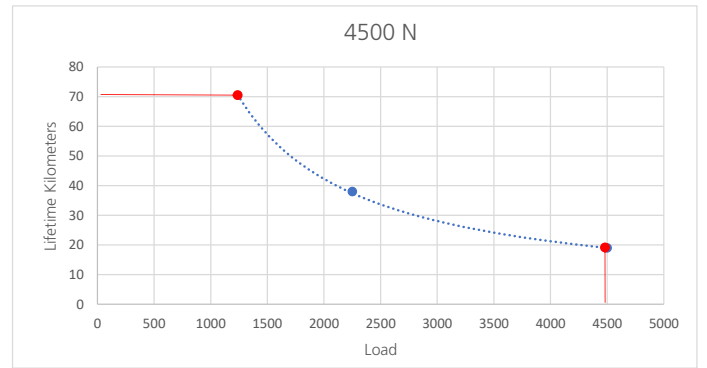
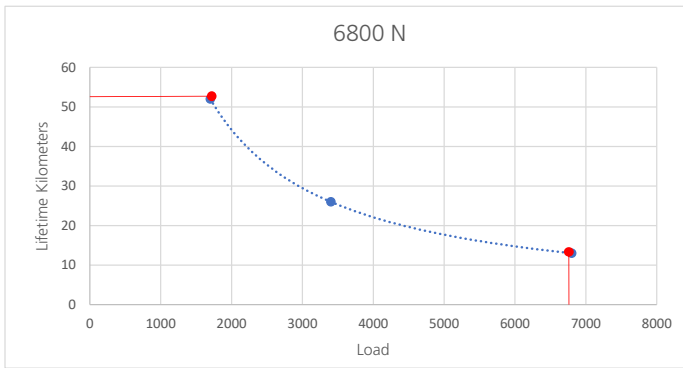

24/48 V DC

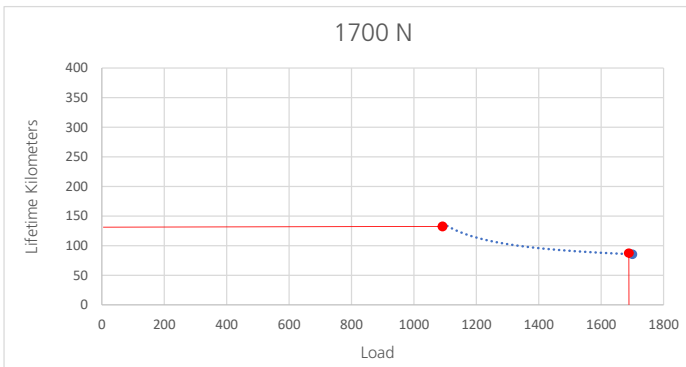
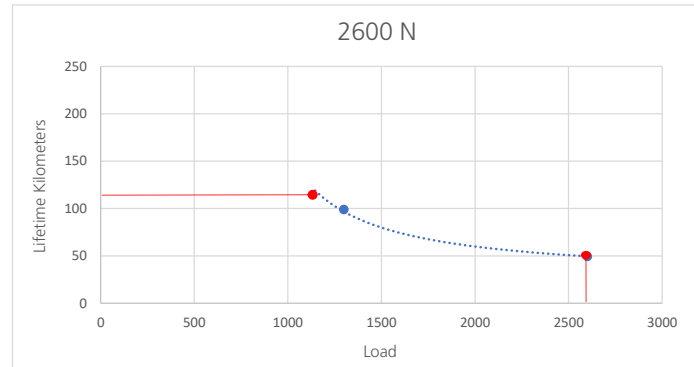
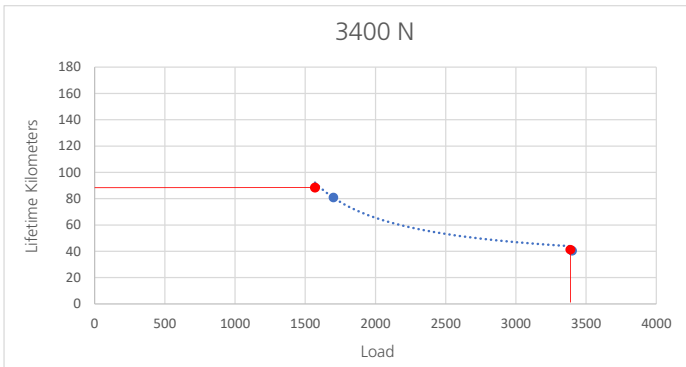
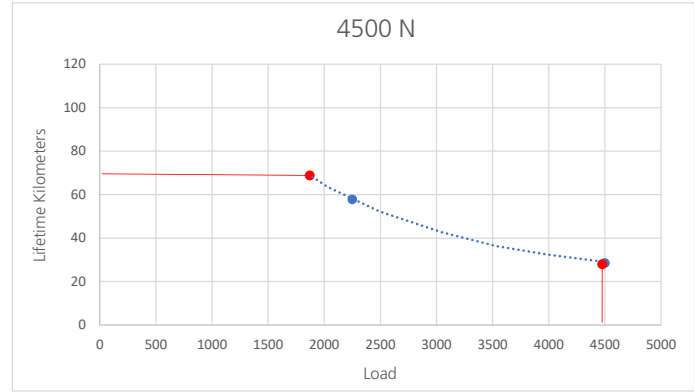
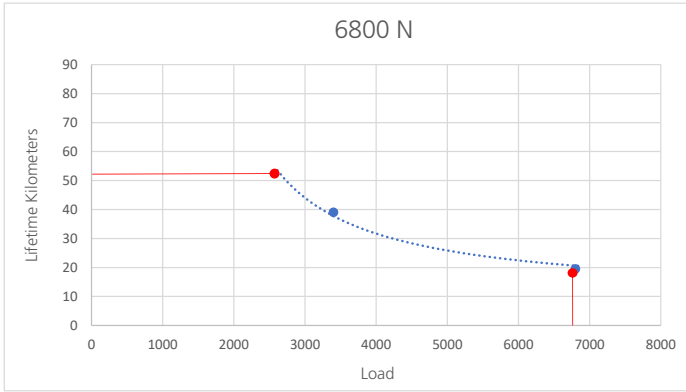

Intermittence

Because the motor and drive within the actuator/lifting column produce heat during operation, the actuator/lifting column needs pauses to avoid excessive wear and overheating.

Intermittence is the ratio between the time when the actuator/lifting column is in motion and when it is paused.

The duty cycle stated in 'Usage' is the intermittence with which the device can be used within the defined 'Operation temperature range' at full load without overheating.

The ratio can be altered with changes to the load and/or changes in the ambient temperature.

Above 40°C: max. 2 minutes continuous run.

Below 40°C: max. 4 minutes continuous run.

The curve describes the duty cycle in % with a given load in a specific ambient temperature.

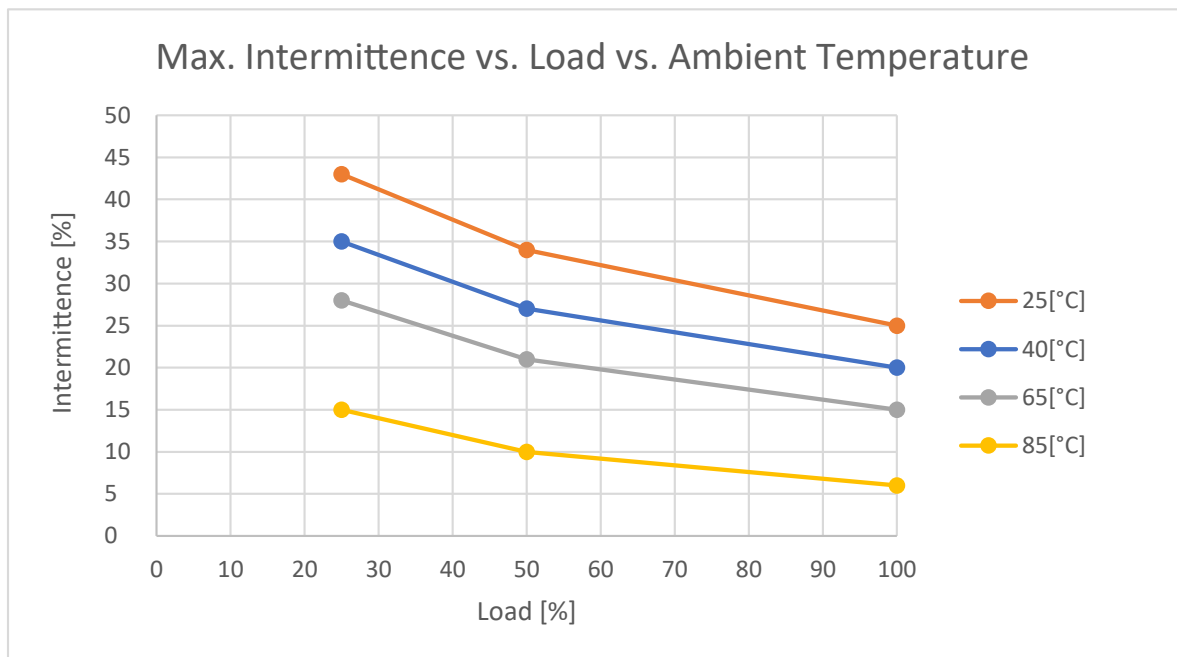

Speed and current curves:

The typical values below are made with a stable power supply and an ambient temperature of 20°C.

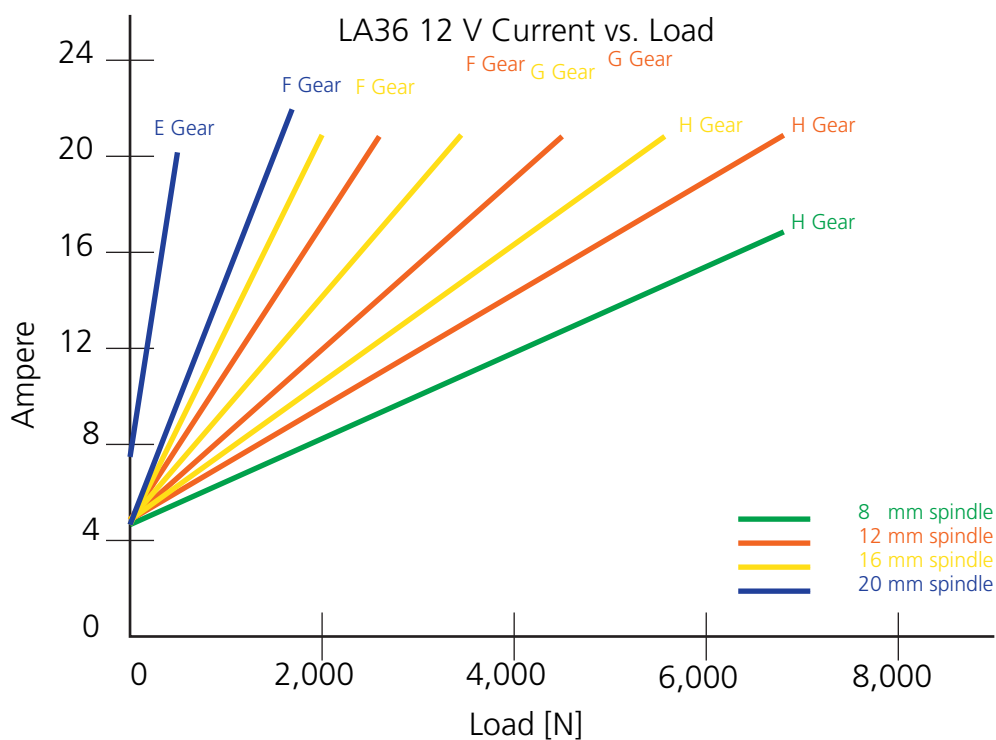
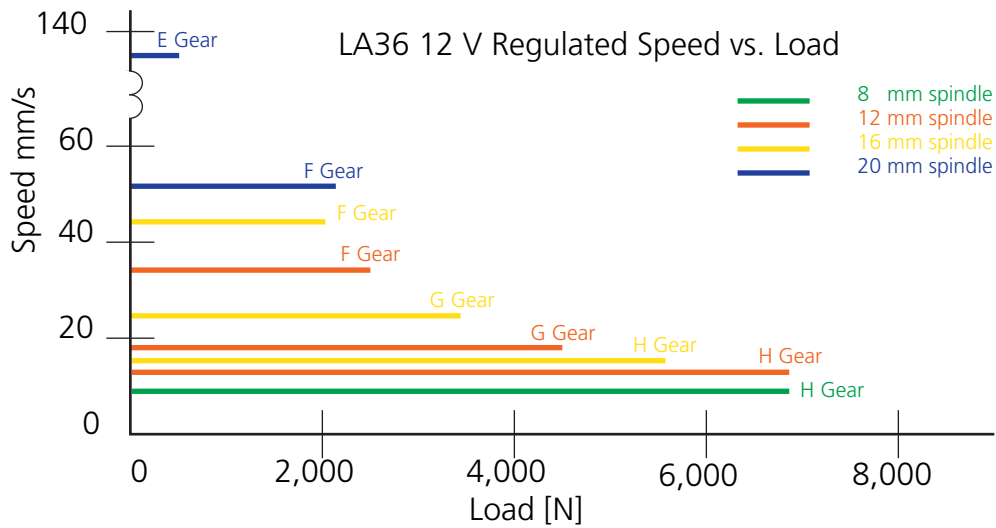
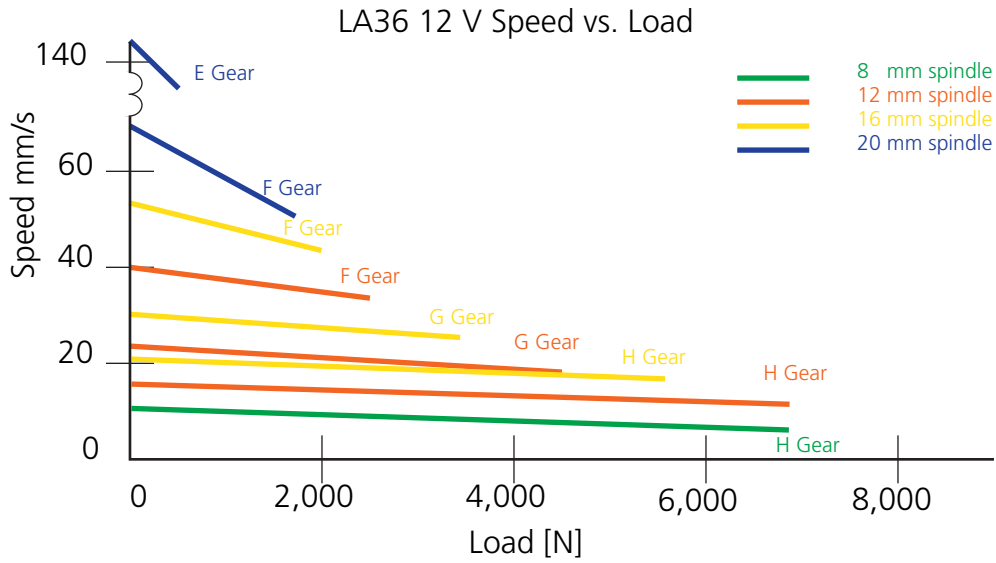

The typical values below are made with a stable power supply and an ambient temperature of 20°C.

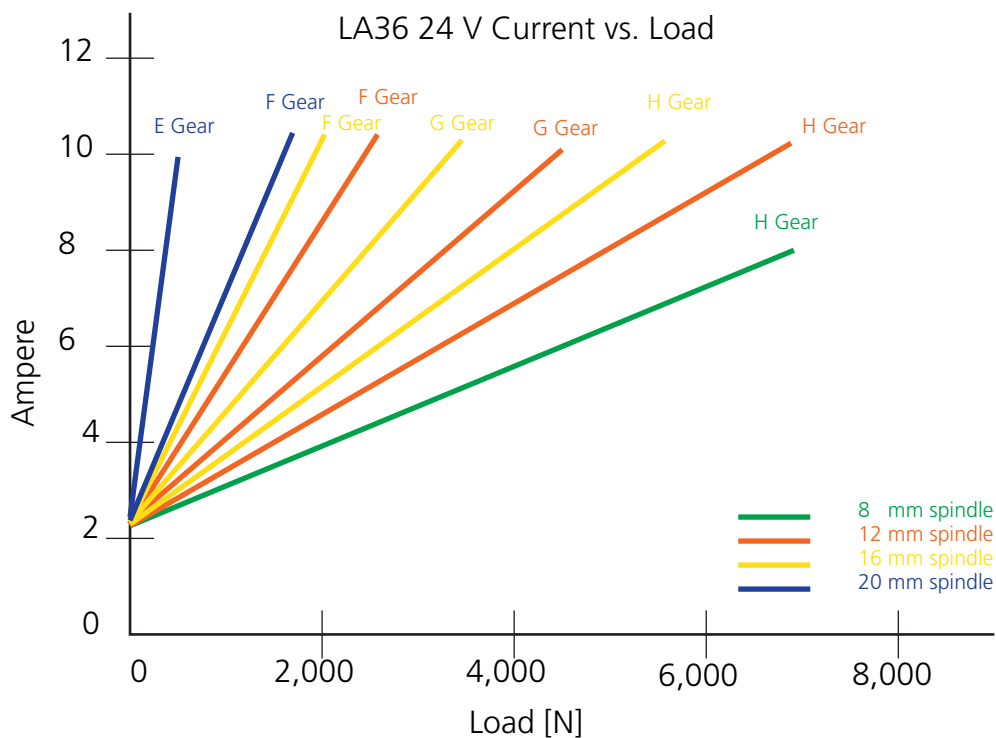
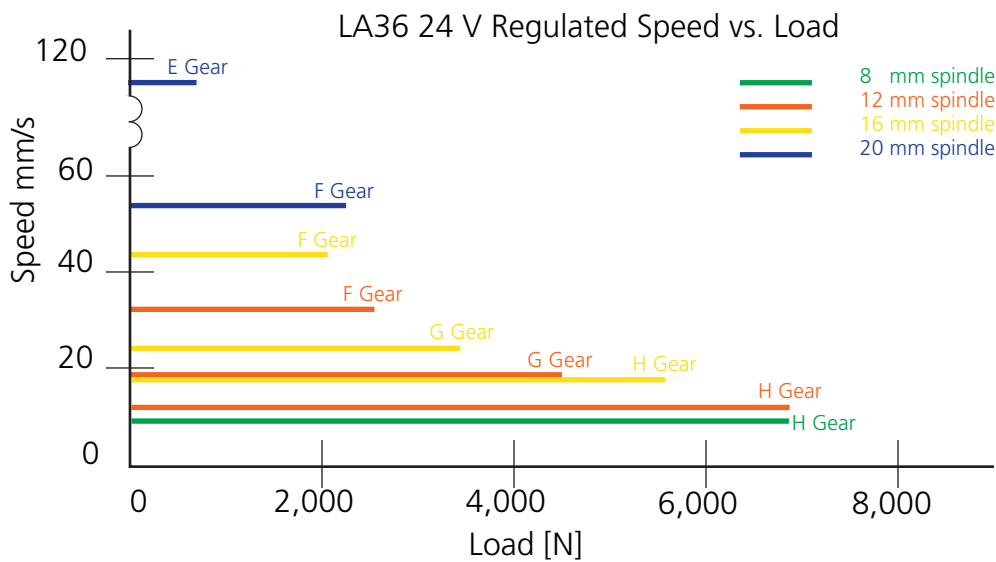
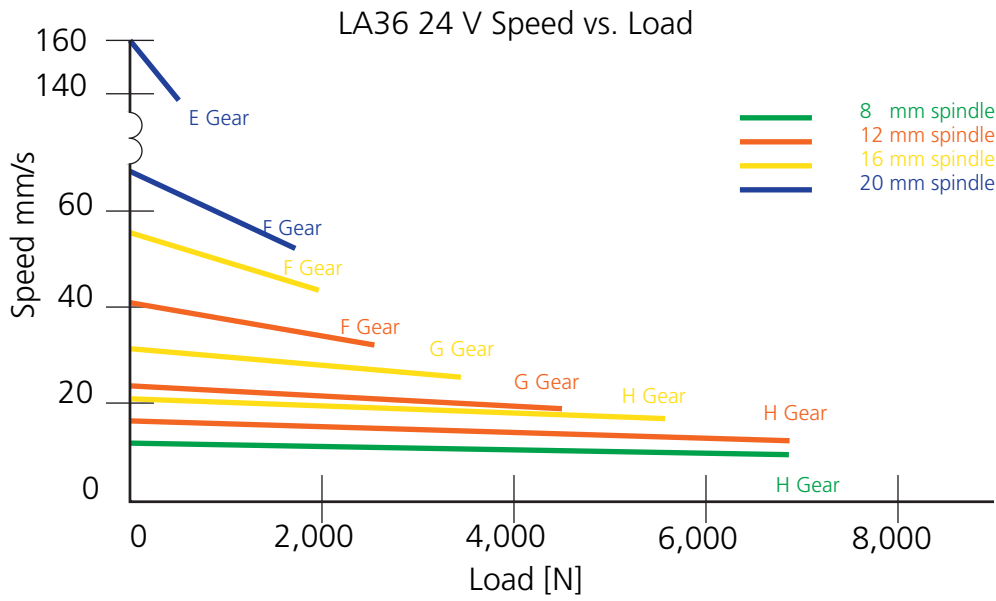

The typical values below are made with a stable power supply and an ambient temperature of 20°C.

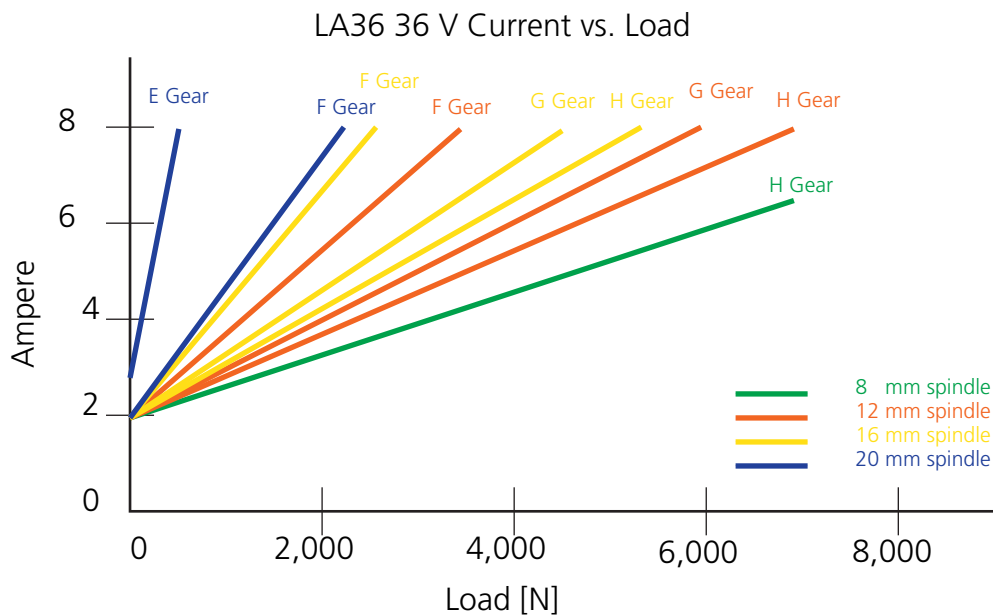
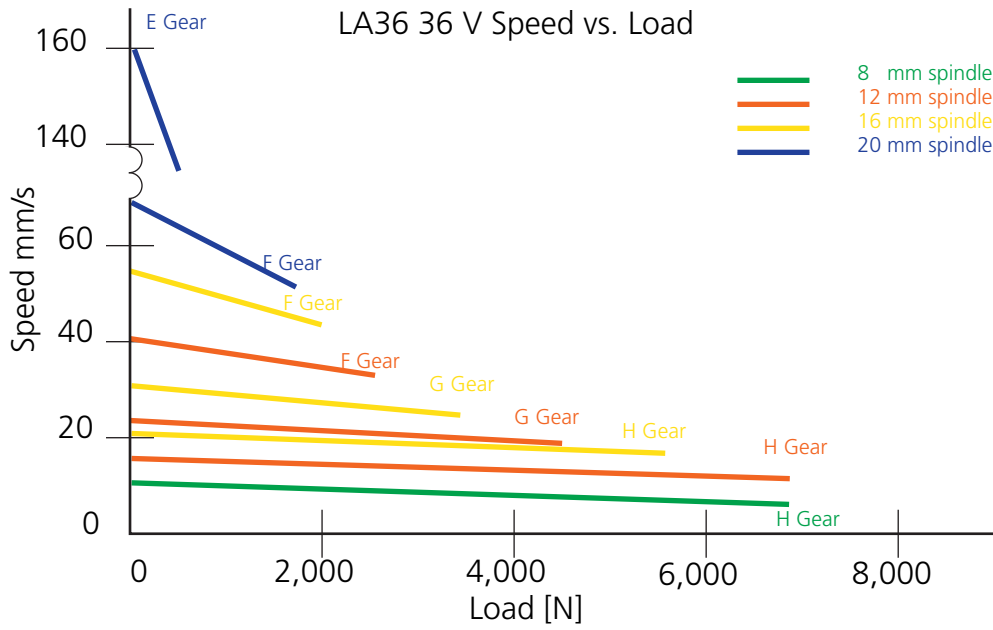

The typical values below are made with a stable power supply and an ambient temperature of 20°C.

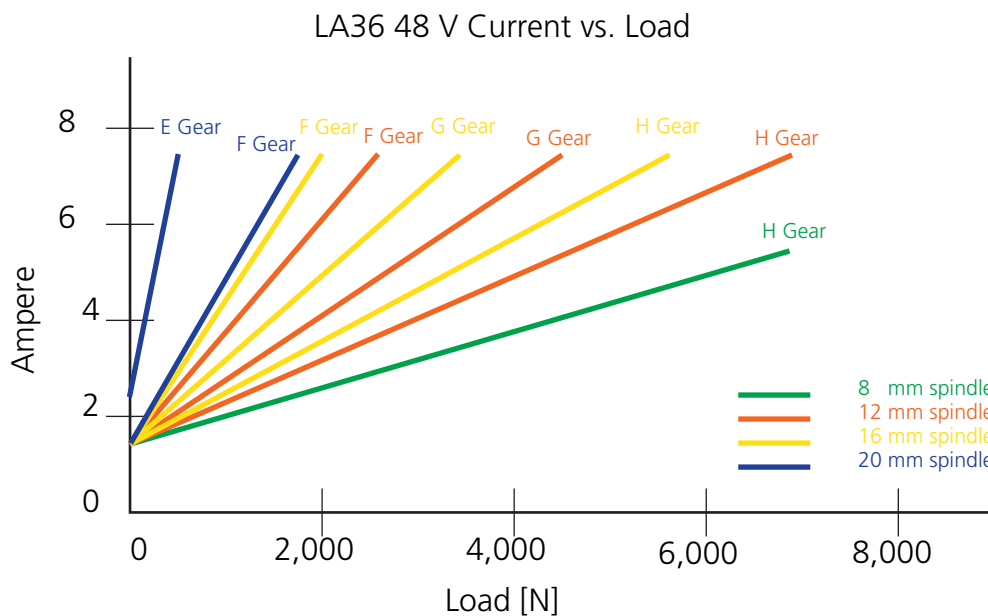
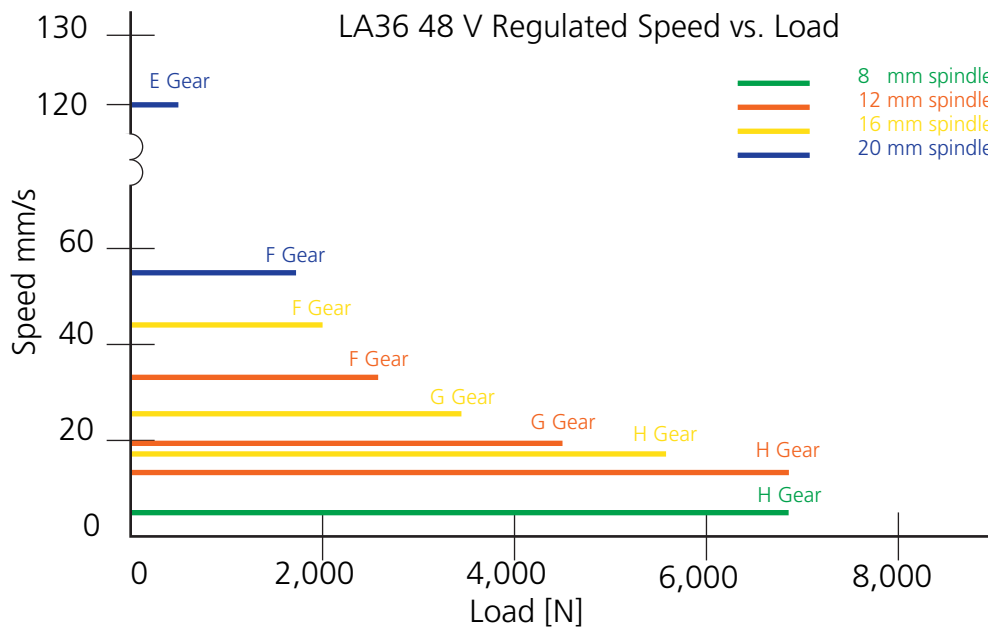
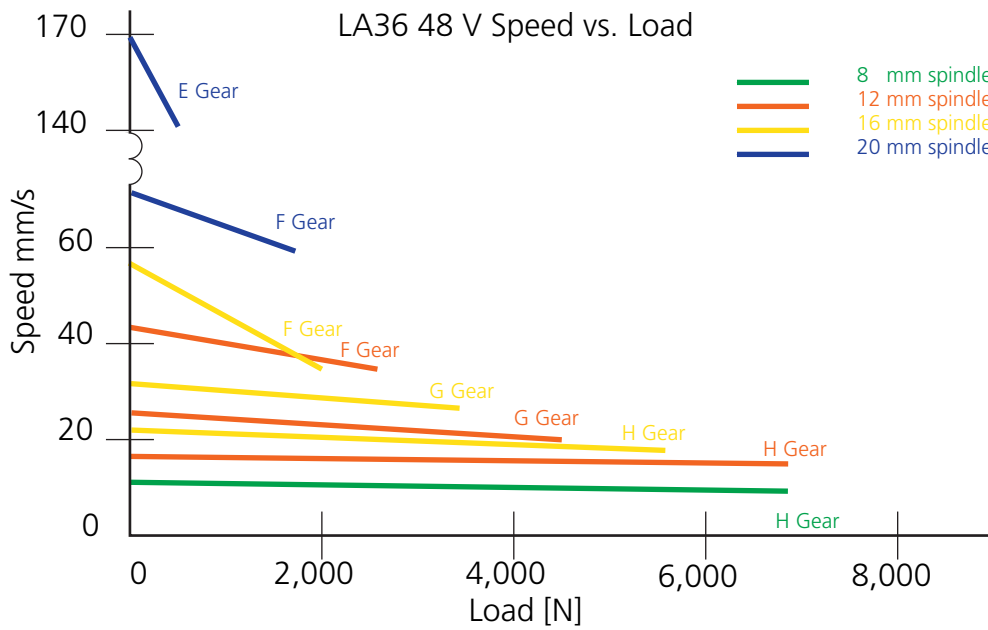

Mounting guidelines

LINAK® linear actuators are quickly and easily mounted by slipping pins through the holes on each end of the units and into brackets on the machine frame and the load.

The mounting pins must be parallel to each other as shown below. Pins, which are not parallel to each other, may cause the actuator to bend and be damaged.

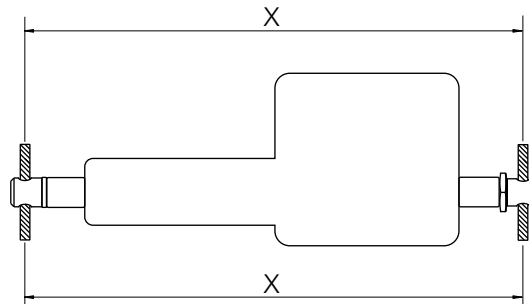

The load should act along the stroke axis of the actuator since off centre loads may cause bending and lead to premature failure. See Figure below.

Support both ends of the mounting pins. Failure to do so could shorten the life of the actuator. Do not use mounts that support the actuator on one side only.

The actuator can rotate around the pivot point in the front and rear end. If this is the case it is of high importance that the actuator is able to move freely over the full stroke length, both during the development and during daily operation. Please pay special attention to the area around the housing where parts can be trapped and cause damages to the application and actuator.

In applications with high dynamic forces LINAK recommends not to use the fully extended or retracted position over longer time, as this can damage the endstop system permanently.

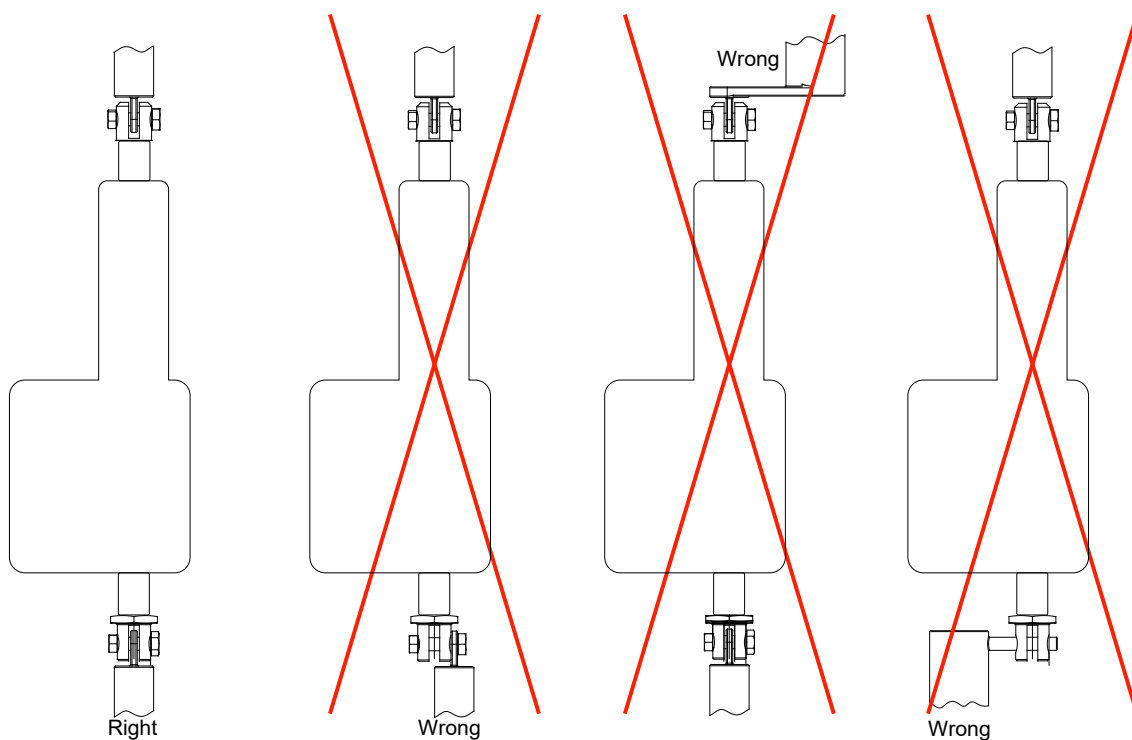

Please note that if the actuator is used in applications where there is moisture, it is recommended to mount the actuator with the motor housing facing upwards and the wires pointing downwards.

Mounting guidelines

- The mounting pins must have the correct dimension
- The bolts and nuts must be made of a high quality steel grade (e.g. 10.8)
- No thread on the bolt inside the back fixture or the piston rod eye. Bolts and nuts must be protected so there is no risk for them to fall out
- Do not use a torque that is too high when mounting the bolts for the back fixture or the piston rod eye. This will stress the fixtures
- If the actuator for some reason does not fit the application, drive the actuator in or out using electric power. DO NOT use excessive force, e.g. a hammer or similar tools, to make the actuator fit the application



Please note:

The piston rod eye is only allowed to turn 0-180 degrees.

Instruction concerning the turning of the piston rod eye and inner tube:

- When mounting and taking into use, it is not permitted to make excessive turns of the piston rod eye. In cases where the eye is not positioned correctly, it is permitted to first screw the eye down to its bottom position, at a maximum torque of 2 Nm (1), and thereafter a maximum 180 degrees turn outwards again (2)
- As the piston rod eye can turn freely, it is important to ensure that the eye cannot rotate if the actuator is used in a pull application. If this happens, the actuator will be pulled apart and destroyed

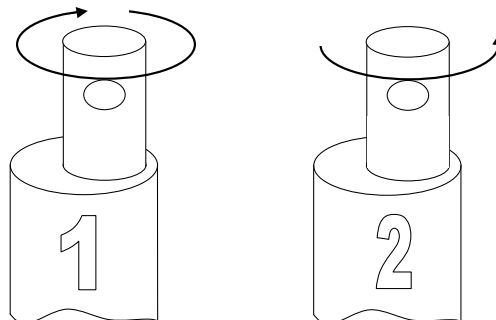

Warning!

If the actuator is used for pull in an application where personal injury can occur, the following is valid:

It is the application manufacturer's responsibility to incorporate a suitable safety arrangement, which will prevent personal injury from occurring, if the actuator should fail.



Warning!

LINAK's actuators are not designed for use within the following fields:

- **Aeroplanes and other aircraft**
- **Nuclear power generation**



Scope for offshore applications: Only if the LINAK® product is not used in the operation of the offshore platform or similar offshore property.

Stroke and built-in tolerances

Platforms		Stroke tolerance	Example for 200 mm stroke	BID tolerance	Example for 300 mm BID
00	Standard with mechanical endstop	± 2 mm	198 to 202 mm	± 2 mm	298 to 302 mm
01	Standard with power switch	± 0/-4 mm	196 to 200 mm	± 4 mm	296 to 304 mm
07 08	CAN SAE J1939 CANopen	± 4/-6 mm	194 to 200 mm	± 4 mm	296 to 304 mm
16 17 18	LIN bus CAN SAE J1939 CANopen	± 2 mm	198 to 202 mm	± 2 mm	298 to 302 mm
B3 C3 F3 0B 14 A7 A8 4E 2E 0E 14 C6 D6 E6	I/O Basic I/O Customised I/O Full IO-Link Modbus RTU CAN SAE J1939 CANopen PROFINET EtherNet/IP Modbus TCP/IP Modbus RTU Off-highway: LIN bus CAN SAE J1939 CANopen	± 2 mm	198 to 202 mm	± 2 mm	298 to 302 mm

Built-in dimensions

All measurements are in mm.

IP66, ATEX / IECEx / CCC approved housing

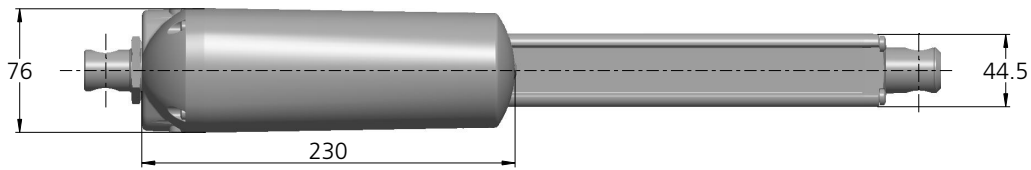
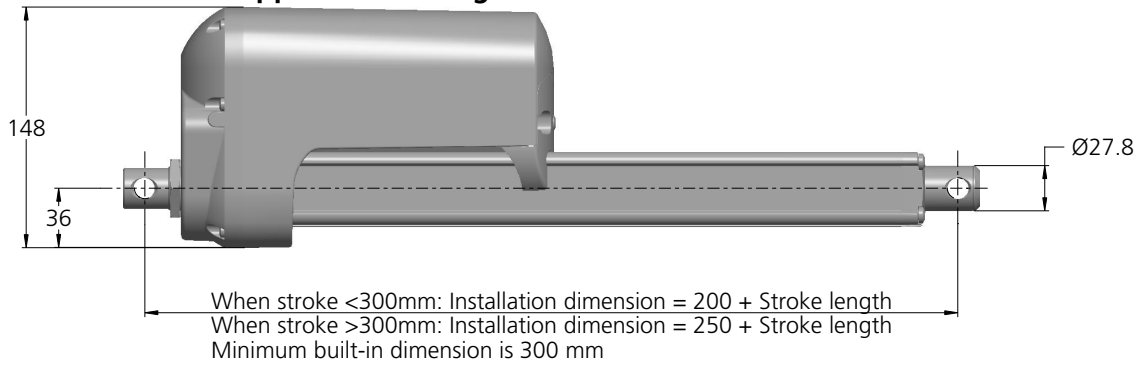

Reinforced housing

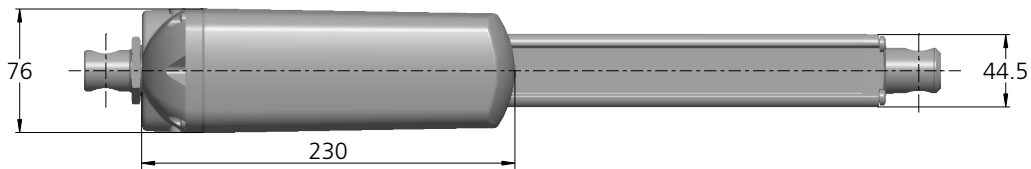
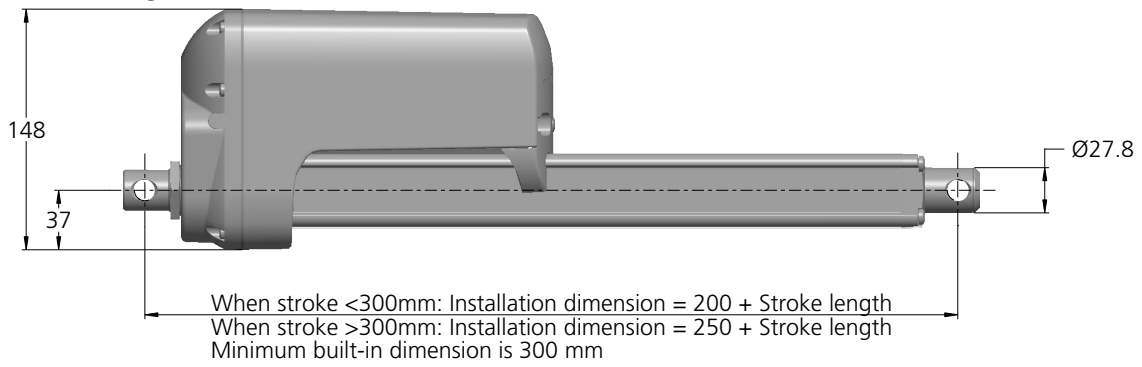

Off-highway

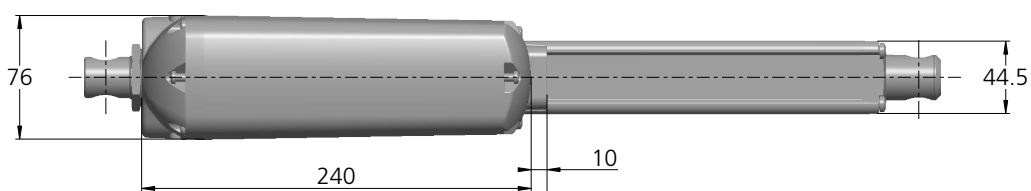
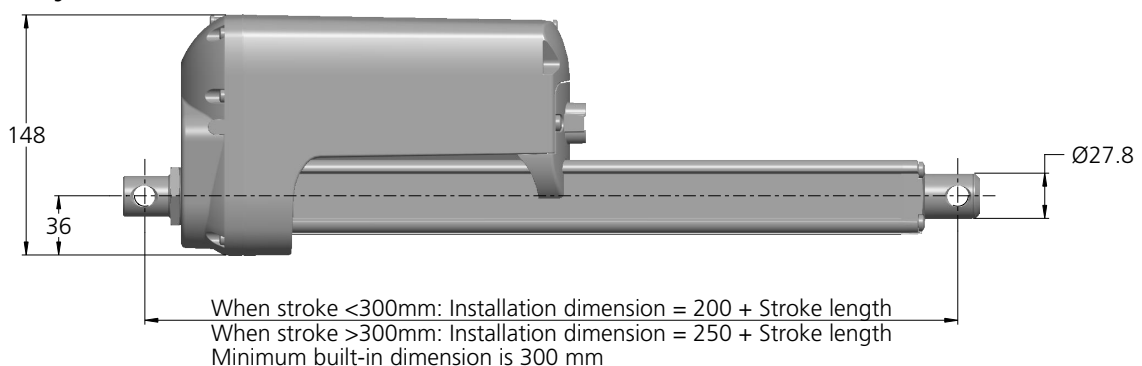

Keep a clearance when mounting a bracket

 When mounting a custom bracket on the moving part of the actuator, please observe the minimum clearance between bracket and cylinder top when fully retracted. This will prevent jamming and destruction of the actuator drive train.

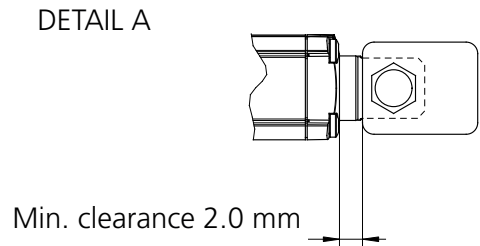
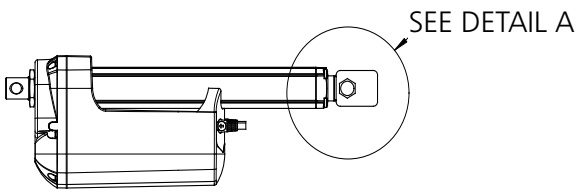



With Zero point the minimum stroke is 75 mm

The Zero point initialisation zone is located between 35-75 mm going from the most inward position.

The movement passing the zone has to be stable for the initialisation to succeed - also no virtual limits can be set in the initialisation zone.

Electrical installation

-  • To ensure maximum self-locking ability, please be sure that the motor is shorted when stopped. Actuators with integrated controller provide this feature, as long as the actuator is powered
- When using soft stop on a DC-motor, the actuator can send a short high-voltage pulse to the power supply. It is important to make sure that it does not turn off the output when this backwards load dump occurs
-  • Deutsch DTP is to be used for power supply in 12 V applications due to the high current draw

The power supply for actuators without integrated controller must be monitored externally and cut off in case of current overload. IC actuators have an integrated overcurrent protection.

Recommended fuse for actuators without Integrated Controller:

Type	Spindle pitch [mm]	Thrust max. push/pull [N]	Typical Ampere at full load [A]				Recommended fuse [A]			
			12 V	24 V	36 V	48 V	12 V	24 V	36 V	48 V
36080xxxxxxxxxxxxH...	8	6,800	22.0	10.4	8.0	7.0	40.0	20.0	16.0	10.0
36120xxxxxxxxxxxxF...	12	2,600	21.0	10.4	8.0	7.0	40.0	20.0	16.0	10.0
36120xxxxxxxxxxxxG...	12	4,500	20.7	10.2	8.0	7.0	40.0	20.0	16.0	10.0
36120xxxxxxxxxxxxH...	12	6,800	21.0	10.3	8.0	7.0	40.0	20.0	16.0	10.0
36200xxxxxxxxxxxxF...	20	1,700	22.0	10.2	8.0	7.0	40.0	20.0	16.0	10.0
36200xxxxxxxxxxxxE...	20	500	20.0	10.0	8.0	7.0	40.0	20.0	16.0	10.0

The current limiting algorithm

The Integrated Controller features the latest current limiting algorithm, which has been significantly improved compared to previous versions.

If the actuator's current consumption rises above the set limit, the actuator reduces speed to stay below the current limit. The actuator does this continuously, until the actuator stops moving (mechanically blocked) - something that is determined by monitoring the Hall feedback signal. If there are no changes to the Hall feedback signal during the set time frame, the integrated controller will cut power to the h-bridge motor circuit.

If the actuator is stopped due to the above-mentioned criteria, it automatically drives slightly in the opposite direction to reduce the torque in a blocking situation.

This is visualised in the figure below:

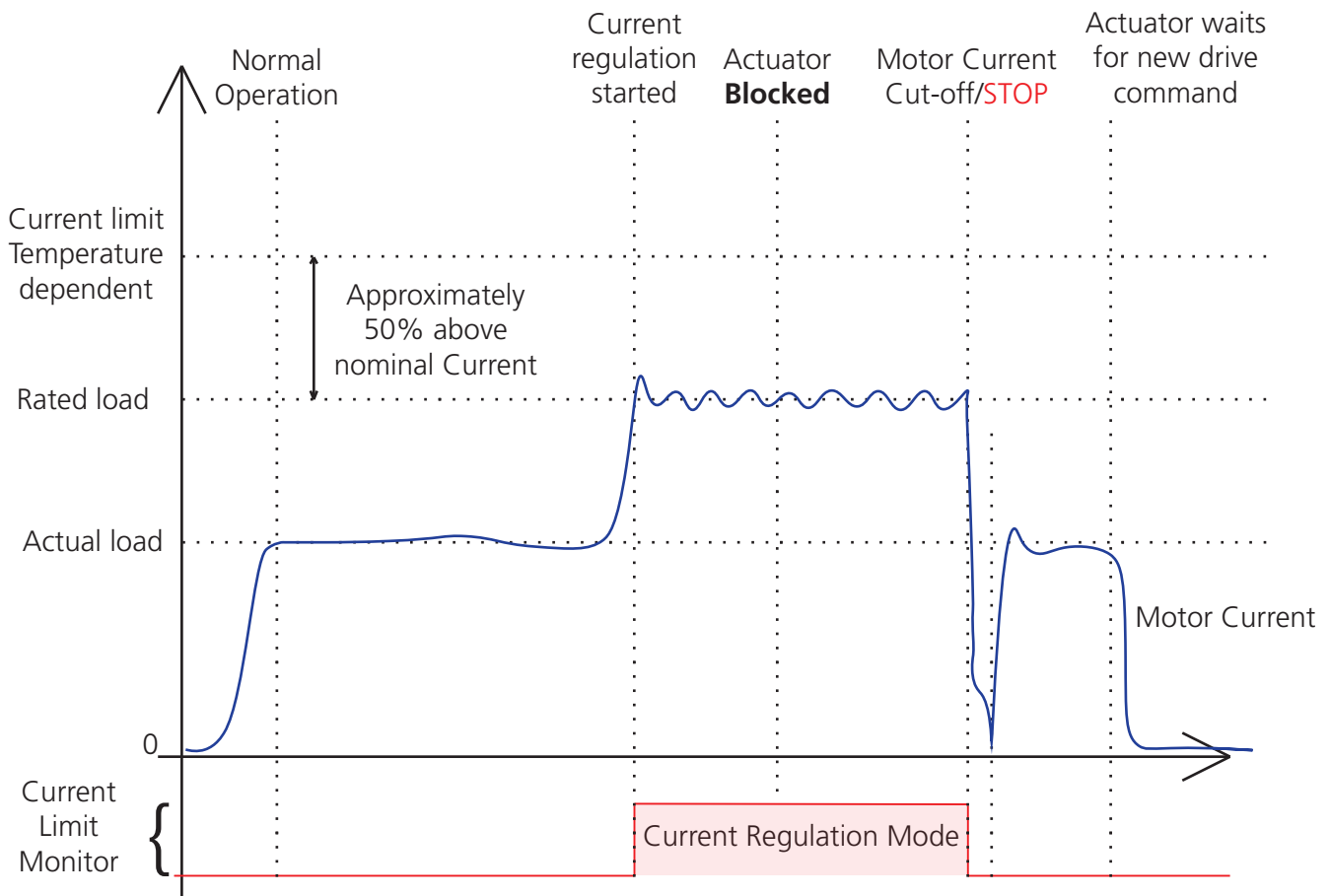

This control feature makes it possible to avoid loading the internal mechanical system of the actuator above its specification, which ultimately means a longer life for the actuator, especially in an abuse scenario.



The Integrated Controller actuator comes with factory default current limits. These values can be customised with the 'Protection' option in Actuator Connect™ or when ordering the actuator.

Current limits

As described in the algorithm on previous page

Platform		12 V	24 V	48 V	Reference temperature: 0°C
B3 C3 F3	I/O Basic	26 A	13 A	8 A	Above
	I/O Customised I/O Full	26 A	26 A	13 A	Below
0B	IO-Link	-	16 A	-	Above
		-	26 A	-	Below
14	Modbus RTU	-	16 A	8 A	Above
		-	26 A	15 A	Below
A7 A8	CANbus J1939 CANopen	-	13 A	8 A	Above
		-	26 A	13 A	Below
0E 2E 4E	Modbus TCP/IP Ethernet PROFINET	-	16 A	8 A	Above
		-	26 A	16 A	Below
C6 D6 E6	Off-highway: LIN bus CAN SAE J1939 CANopen	26 A	13 A	-	Above
		26 A	26 A	-	Below

Max. Current

The current is not limited by the actuator below is the anticipated consumption at max. load.
See: Recommended fuse for actuators without Integrated Controller

Platform		12 V	24 V	36 V	48 V	Reference temperature: 0°C
00 01	Standard	26 A	13 A	10 A	8 A	Above
	Standard with power switch	26 A	13 A	10 A	8 A	Below

Current cut-offs

The principle behind the current cut-off measurement is an 'above limit' and a 'below limit' accumulating counter. When the time-out counter reaches a specific value the current cut-off goes into effect.

The system stops after 200 milliseconds if the current is too high.

Platform		12 V	24 V	48 V	Reference temperature: 0°C
16	LIN bus	30 A	-	-	Above
		30 A	-	-	Below
07 08	CAN SAE J1939 CANopen	30 A	20 A	13 A	Above
		30 A	25 A	15 A	Below
17 18	CAN SAE J1939 CANopen	30 A	20 A	-	Above
		30 A	25 A	-	Below

Mounting of cables

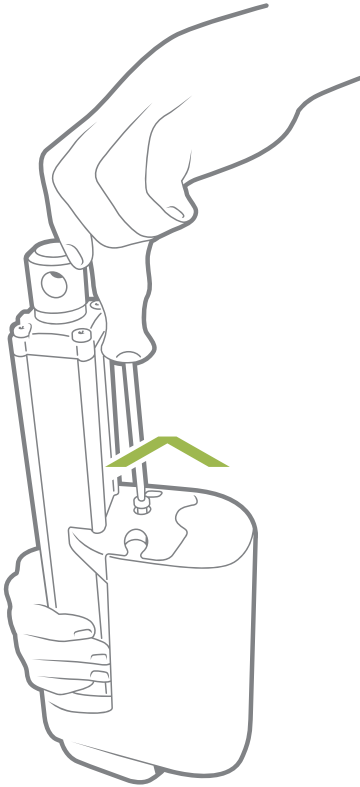

1. Unscrew the screw and separate the cover from the housing. Remove the blind plug(s).

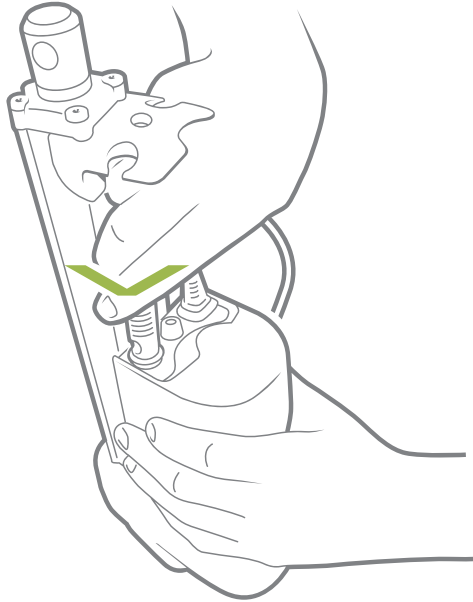

2. Plug in the power cable and/or the signal cable.

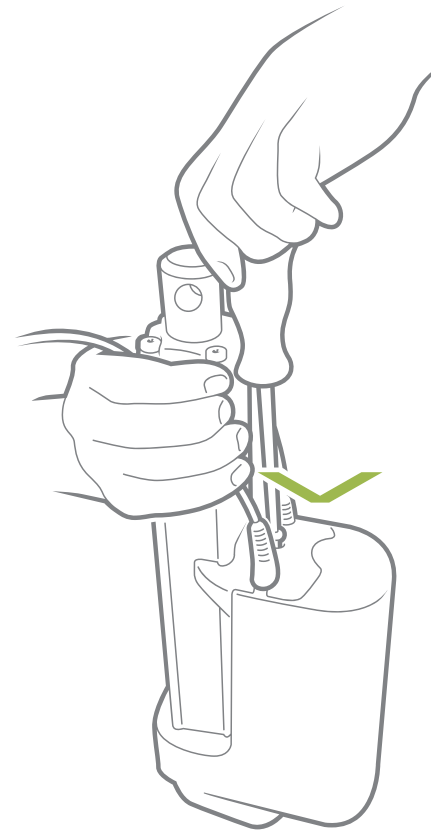

3. Slide the cover onto the actuator. The torque of the cover screw is approx. 3.5 ± 0.3 Nm TORX 25IP



When changing the cables on a LINAK® actuator, it is important that this is done carefully, in order to protect the plugs and pins. Before the new cable is mounted, we recommend that the socket is greased with vaseline, to keep the high IP protection and ensure an easy mounting. Please be sure that the plug is in the right location and fully pressed in before the cable lid is mounted.

Cut off the tinned end if you connect the cable with screws. The tinned end is only to be used when a soldered connection is made.

Please note that if the cables are mounted and dismantled more than 3 times the plugs can be damaged. Therefore, we recommend that such cables are discarded and replaced. Do not lift the actuator by the cables.

We recommend to take some precaution and design the wire connection in a way, where the cable end is kept inside a closed, protected area to guarantee the high IP protection.



NOT valid for ATEX cables, please refer to the ATEX section for correct cable mounting on ATEX actuators.

Mounting of cable with Off-highway

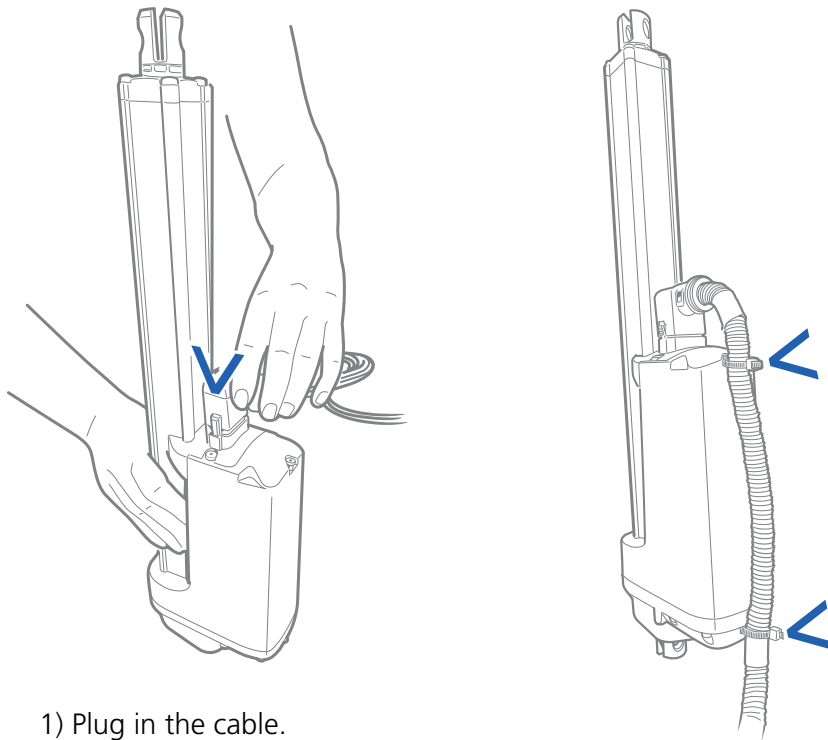

1) Plug in the cable.

An audible "Click" confirms a correct mounting

2) Secure the cable with cable-ties to the two anchors

 We recommend to take some precaution and design the wire connection in a way, where the cable end is kept inside a closed, protected area to guarantee the high IP protection.

Off-highway connection to Actuator Connect™

When connecting the actuator to Actuator Connect™ it is imperative to follow these instructions.

Power supply connection:

The actuator has to be powered with 12 Volt DC

Positive is connected to pin 4 at the actuator

GND is connected to pin 11 at the actuator

RJ45:

Pin 1 at the RJ45 plug is Ground and has to be interconnected to GND on pin 11 at the actuator

Pin 6 and 8 at the RJ45 plug is communication and both has to be connected to pin 10 at the actuator:

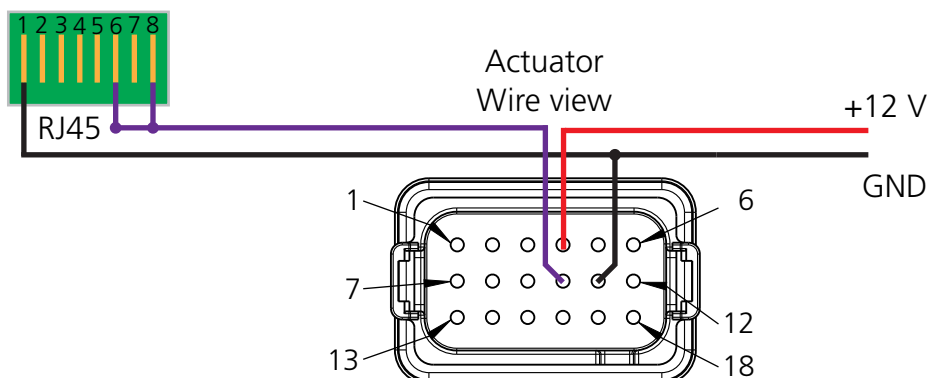

Manual hand crank:

The manual Hand Crank can be used in the case of a power failure -it is only intended for emergency use.



The manual hand crank must **NEVER** be used in an ATEX/IECEX/CCC environment, as it is not possible to verify that the actuator is properly sealed after the hand crank has been used.

The actuator must **NOT** be used in an ATEX/IECEX/CCC environment, if the warning sticker is missing or shows sign of having been removed from the bottom of the actuator.

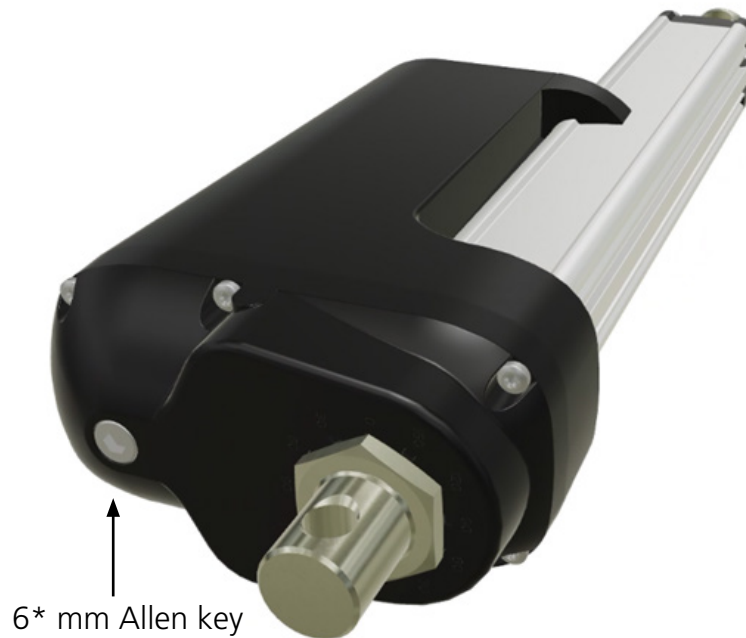

The cover over the allen key socket must be unscrewed before the allen key can be inserted and the hand crank operated.

Hand crank torque: 6-8 Nm

Hand crank rpm: Max. 65

Piston rod movement per hand crank turn:				
Spindle type:	8 mm	12 mm	16 mm	20 mm
Gear F:	-	11 mm	14 mm	18 mm
Gear G:	-	6 mm	8 mm	10 mm
Gear H:	3 mm	4 mm	5 mm	7 mm
Gear E:	-	-	-	27 mm

* 5 mm Allen key -if stainless steel piston rod eye and back fixture are chosen



- The power supply has to be disconnected during manual operation
- If the actuator is operated as a hand crank, it must only be operated by hand, otherwise there is a potential risk of overloading and thereby damaging the actuator
Use your hand to turn the crank. Do not use power tools!
- After using the hand crank, the ingress protection will be less than IP66 once the plug is removed
- Move the actuator to its starting position after using the crank
Failing to do so can damage the actuator and/or the application it is used for

Label for LA36

LINAK® 

Designed in Denmark

DK - 6430 Nordborg

Type : 3612025000B32B=612H30450ACS000

Item No. : J06292

Prod. Date : 2024.03.20

Max Load : Push 6800 N / Pull 6800 N IP66

Power Rate: 24 V_{DC}, Max 13 A

Duty Cycle : 20% Max. 4 min/16 min

Model : LA36IO ; FCC ID: XBE-LAXXIO ; IC: 12338B-LAXXIO



W/O# -0001

Made in Denmark



1. **Type: 3612025000B32B=612H30450ACS000**
Describes the basic functionality of the product
2. **Item no.: J06292**
Sales and ordering code
3. **Prod. Date: YYYY.MM.DD**
Production date describes when the product has been produced. This date is the reference for warranty claims
4. **Max Load: Push 6800 N / Pull 6800 N IP66**
Describes the maximum load that the product can be exposed to in compression and tension. This line also contains a reference to the product's IP protection degree
5. **Power Rate: 24 VDC / Max. 13 Amp**
Input voltage for the product and maximum current consumption
6. **Duty Cycle: 20%, Max. 4 min. / 16 min.**
The duty cycle defines the maximum period during operation without interruption. After operation, a pause must be observed. It is important that the operator follows the instructions of the duty cycle; otherwise, a possible overload may result in reduced product life/errors
7. **W/O #12345678-0001**
The LINAK work order followed by a unique sequential identification number

Maintenance

- The actuator must be cleaned at regular intervals to remove dust and dirt, and it must be inspected for mechanical damages or wear.
- Inspect attachment points, wires, piston rod, cabinet, and plug. Also check whether the actuator functions correctly.
- To ensure that the pre-greased inner tube remains lubricated, the actuator must only be washed down when the piston rod is fully retracted.
- The actuator is a closed unit and therefore requires no internal maintenance.
- In order to maintain a proper performance of the spherical eyes and to increase the resistance against environmental wear, we strongly recommend that the spherical eyes (ball bearings) mounted on actuators from LINAK® are greased with anticorrosive grease or similar.

Repair

See warranty disclaimer.

Main groups of disposal

LINAK's products may be disposed of, possibly by dividing them into different waste groups for recycling or combustion.

We recommend that our product is disassembled as much as possible at the disposal and that you try to recycle it.

Product	Metal scrap	Cable scrap	Electronic scrap	Plastic recycling or combustion
LA36	X	X	X	X

Warranty

There is an 18 months' warranty on TECHLINE® products against manufacturing faults calculated from the production date of the individual products (see label). LINAK's warranty is only valid in so far as the equipment has been used and maintained correctly and has not been tampered with. Furthermore, the actuator must not be exposed to violent treatment. In the event of this, the warranty will be ineffective/invalid. For further details, please see standard terms of sale and delivery for LINAK A/S.

Note

Only an authorised LINAK service centre should repair LINAK actuator systems. Systems to be repaired under warranty must be sent to an authorised LINAK service centre.

In order to avoid the risk of malfunction, all actuator repairs must only be carried out by an authorised LINAK Service shop or repairer, as special tools and parts must be used.

If a system is opened by unauthorised personnel there is a risk that it may malfunction at a later date.

The actuator is not to be opened by unauthorised personnel. In case the actuator is opened, the warranty will be invalid.

Maintenance

- The actuator must be cleaned at regular intervals to remove dust and dirt, and it must be inspected for mechanical damages or wear.
- Inspect attachment points, wires, piston rod, cabinet, and plug. Also check whether the actuator functions correctly.
- To ensure that the pre-greased inner tube remains lubricated, the actuator must only be washed down when the piston rod is fully retracted.
- The actuator is a closed unit and therefore requires no internal maintenance.
- In order to maintain a proper performance of the spherical eyes and to increase the resistance against environmental wear, we strongly recommend that the spherical eyes (ball bearings) mounted on actuators from LINAK® are greased with anticorrosive grease or similar.

Repair

See warranty disclaimer.

Main groups of disposal

LINAK's products may be disposed of, possibly by dividing them into different waste groups for recycling or combustion.

We recommend that our product is disassembled as much as possible at the disposal and that you try to recycle it.

Product	Metal scrap	Cable scrap	Electronic scrap	Plastic recycling or combustion
LA36	X	X	X	X

Warranty

There is an 18 months' warranty on TECHLINE® products against manufacturing faults calculated from the production date of the individual products (see label). LINAK's warranty is only valid in so far as the equipment has been used and maintained correctly and has not been tampered with. Furthermore, the actuator must not be exposed to violent treatment. In the event of this, the warranty will be ineffective/invalid. For further details, please see standard terms of sale and delivery for LINAK A/S.

Note

Only an authorised LINAK service centre should repair LINAK actuator systems. Systems to be repaired under warranty must be sent to an authorised LINAK service centre.

In order to avoid the risk of malfunction, all actuator repairs must only be carried out by an authorised LINAK Service shop or repairer, as special tools and parts must be used.

If a system is opened by unauthorised personnel there is a risk that it may malfunction at a later date.

The actuator is not to be opened by unauthorised personnel. In case the actuator is opened, the warranty will be invalid.



DECLARATION OF CONFORMITY

LINAK A/S
Smedevænget 8
DK - 6430 Nordborg

hereby declares that

Actuator (LA36 std.) 36****0*****, 36****1*****, 36****2*****,
 (LA36 std.) 36****000**_*****, 36****001**_*****,
 36****A00**_*****, 36****A01**_*****,
 36****B00**_*****, 36****B01**_*****,
 36****C00**_*****, 36****C01**_*****,
 36****F00**_*****, 36****F01**_*****,
 36****H00**_*****, 36****H01**_*****,
 36****K00**_*****, 36****K01**_*****,
 36****P00**_*****, 36****P01**_*****,
 36****Z00**_*****, 36****Z01**_*****,

(LA37 std.) 37****0*****, 37****1*****, 37****2*****,
 (LA37 std.) 37****000**_*****, 37****001**_*****,
 37****A00**_*****, 37****A01**_*****,
 37****B00**_*****, 37****B01**_*****,
 37****C00**_*****, 37****C01**_*****,
 37****F00**_*****, 37****F01**_*****,
 37****H00**_*****, 37****H01**_*****,
 37****K00**_*****, 37****K01**_*****,
 37****P00**_*****, 37****P01**_*****,
 37****Z00**_*****, 37****Z01**_*****,

(The "*" in the product description can either be a character or a number, thereby defining the variation of the product)

complies with the EMC Directive 2014/30/EU according to following standards:
 EN 61000-6-2:2019, 61000-6-4:2019

complies with the ATEX Directive 2014/34/EU according to following standards:
 EN IEC 60079-0:2018, EN 60079-31:2014
 TÜV NORD CERT GmbH, Notified Body No. 0044. Certificate Number TÜV 15 ATEX 143747 X

NOTE: Applies only for ATEX specified actuators. Marking plate shows the CE-ATEX approval marking.

complies with the RoHS2 Directive 2011/65/EU according to the standard:
 EN IEC 63000:2018

Nordborg, 2025-03-06

LINAK A/S
 John Kling, B.Sc.E.E.
 Regulatory Affairs Manager
 Authorized to compile the relevant technical documentation

This declaration of conformity is issued under the sole responsibility of the manufacturer.

Original Declaration



DECLARATION OF CONFORMITY

LINAK A/S
Smedevænget 8
DK - 6430 Nordborg

hereby declares that

Actuator
(LA361C) 36*****7***** , 36*****8***** , 36*****9***** , 36*****B*****
(LA361C) 36*****03**_***** , (LA361C) 36*****13**_*****
(LA361C) 36*****23**_***** , (LA361C) 36*****33**_*****
(LA361C) 36*****43**_***** , (LA361C) 36*****53**_*****
(LA361C) 36*****63**_*****

(LA371C) 37*****7***** , 37*****8***** , 37*****9***** , 37*****B*****
(LA371C) 37*****03**_***** , (LA371C) 37*****13**_*****
(LA371C) 37*****23**_***** , (LA371C) 37*****33**_*****
(LA371C) 37*****43**_***** , (LA371C) 37*****53**_*****
(LA371C) 37*****63**_*****

(The "*" in the product description can either be a character or a number, thereby defining the variation of the product)

complies with the EMC Directive: 2014/30/EU according to following standards:
EN 61000-6-1:2019, EN 61000-6-2:2019, EN 61000-6-3:2021, EN 61000-6-4:2019

complies with the ATEX Directive 2014/34/EU according to following standards:
EN IEC 60079-0:2018, EN 60079-31:2014
TÜV NORD CERT GmbH, Notified Body No. 0044. Certificate Number TÜV 15 ATEX 143747 X

NOTE: Applies only for ATEX specified actuators. Marking plate shows the CE-ATEX approval marking.

complies with RoHS2 Directive 2011/65/EU according to the standard:
EN 63000:2018

Nordborg, 2025-03-06

LINAK A/S
John Kling, B.Sc.E.E.
Regulatory Affairs Manager
Authorized to compile the relevant technical documentation

This declaration of conformity is issued under the sole responsibility of the manufacturer

Original Declaration



DECLARATION OF CONFORMITY

LINAK A/S
Smedevænget 8
DK - 6430 Nordborg

hereby declares that

Actuator 36*****A72B=***** , 36*****A74B=***** , 36*****A82B=***** ,
36*****A84B=*****

37*****A72B=***** , 37*****A74B=***** , 37*****A82B=***** ,
37*****A84B=*****

(The "*" in the product description can either be a character or a number, thereby defining the variation of the product)

complies with the EMC Directive 2014/30/EU according to following standards:
EN 61000-6-1:2019, EN 61000-6-2:2019, EN 61000-6-3:2021, EN 61000-6-4:2019

complies with the ATEX Directive 2014/34/EU according to following standards:
EN IEC 60079-0:2018, EN 60079-31:2014
TÜV NORD CERT GmbH, Notified Body No. 0044. Certificate Number TÜV 15 ATEX 143747 X

NOTE: Applies only for ATEX specified actuators. Marking plate shows the CE-ATEX approval marking.

complies with the RoHS2 Directive 2011/65/EU according to the standard:
EN 63000:2018

Nordborg, 2025-03-06

LINAK A/S
John Kling, B.Sc.E.E.
Regulatory Affairs Manager
Authorized to compile the relevant technical documentation

This declaration of conformity is issued under the sole responsibility of the manufacturer.

Original Declaration



DECLARATION OF CONFORMITY

LINAK A/S
Smedevænget 8
DK - 6430 Nordborg

hereby declares that

Actuator
(LA36 BUS) 36*****AD***B**
(LA36 BUS) 36*****04*****

(LA37 BUS) 37*****AD***B**
(LA37 BUS) 37*****04*****

(The '*' in the product description can either be a character or a number, thereby defining the variation of the product)

complies with the EMC Directive: 2014/30/EU according to following standards:
EN 61000-6-1:2019, EN 61000-6-2:2019, EN 61000-6-3:2021, EN 61000-6-4:2019

complies with the ATEX Directive 2014/34/EU according to following standards:
EN IEC 60079-0:2018, EN 60079-31:2014
TÜV NORD CERT GmbH, Notified Body No. 0044. Certificate Number TÜV 15 ATEX 143747 X

NOTE: Applies only for ATEX specified actuators. Marking plate shows the CE-ATEX approval marking.

complies with RoHS2 Directive 2011/65/EU according to the standard:
EN 63000:2018

Nordborg, 2025-03-06

LINAK A/S
John Kling, B.Sc.E.E.
Regulatory Affairs Manager
Authorized to compile the relevant technical documentation

This declaration of conformity is issued under the sole responsibility of the manufacturer

Original Declaration



DECLARATION OF CONFORMITY

LINAK A/S
Smedevænget 8
DK - 6430 Nordborg

hereby declares that

Actuator
(LA36 Mobile) 36*****C6*****
36*****E6*****

(LA37 Mobile) 37*****C6*****
37*****E6*****

(The '*' in the product description can either be a character or a number, thereby defining the variation of the product)

complies with the EMC Directive: 2014/30/EU according to following standards:
EN 61000-6-1:2019, EN 61000-6-2:2019, EN 61000-6-3:2021, EN 61000-6-4:2019

complies with RoHS2 Directive 2011/65/EU according to the standard:
EN 63000:2018

Nordborg, 2024-02-16

LINAK A/S
John Kling, B.Sc.E.E.
Regulatory Affairs Manager
Authorized to compile the relevant technical documentation

This declaration of conformity is issued under the sole responsibility of the manufacturer.
Original Declaration

DECLARATION OF INCORPORATION OF PARTLY COMPLETED MACHINERY

LINAK A/S
Smedevænget 8
DK - 6430 Nordborg

LINAK A/S hereby declares that LINAK DESKLINE® products, characterised by the following models and types:

Control Boxes	CBD6S
Linear Actuators	DB5, DB6, DB14, LA23, LA31
Lifting Columns	DL1A, DL2, DL4S, DL5, DL6, DL8, DL9, DL10, DL11, DL12, DL14, DL15, DL16, DL17, DL18, DL19, DL20, DL21, BASE1, LC1
Desk Panels	DPA, DPB, DPH, DPF, DPG, DPT, DP, DP1CS, DPI
Wireless Controls	BP10
Frames and Feet	Kick & Click, DF2, DF3, DLF
Accessories	BA001, BLE2LIN, CHUSB, DESK Sensor, SLS, SMPS, USB2LIN, WiFi2LIN, DC Connector, RFRL

LINAK A/S hereby declares that LINAK HOMELINE® products, characterised by the following models and types:

Control Boxes	CBD6DC
Linear Actuators	LA10, LA18, LA40 HOMELINE
Dual Actuators	TD4, TD5
Controls	BP10, HC10, HC20, HC40
Accessories	BA002, CP, BLE2DC, BLE2LIN, LED Light Rail, MD1, SMPS, WiFi2LIN

LINAK A/S hereby declares that LINAK MEDLINE® & CARELINE® products, characterised by the following models and types:

Control Boxes	CA10, CA20, CA30, CA40, CA63, CAL40, CB6, CB6S, CB6P2, CB8, CB9, CBJ2, CBJ Care, CBJ Home, CO41, CO53, CO61, CO65, CO71, COL50, OPS, PJ2
Linear Actuators	KA19, KA30, KA30 ICA, LA20, LA23, LA24, LA24 ICA, LA27, LA28, LA29, LA30, LA31, LA34, LA40, LA42, LA44
Lifting Columns	BL1, LC1, LC3
Controls	ABL, ACC, ACK, ACO, ACOD, ACOM, ACL, DP, DPH, FS, FS3, FPP, HB30, HB70, HB80, HB100, HB190, HB200, HB400, HD80, HL70, HL400, SC01
Accessories	BA15, BA16, BA18, BA19, BA22, BAJ, BAJL, BAL40, BAL50, CH01, CHJ2, CHL40, CHL50, DJB, LIN2OB, MJB2, MJB5 Plus, Massage Motor, PJB4, QLCI2, SLS, SMPS10, UBL, UBL2, UBL4 Motion, USB-A Power Adapter

LINAK A/S hereby declares that LINAK TECHLINE® products, characterised by the following models and types:

Linear Actuators	LA12, LA14, LA21, LA23, LA25, LA30, LA33, LA35, LA36, LA37, LA73, LA76, LA77
Lifting Columns	LC3 IC
Accessories	FMB

comply with the following parts of the Machinery Directive 2006/42/EC, ANNEX I, Essential health and safety requirements relating to the design and construction of machinery: 1.5.1 Electricity supply

The relevant technical documentation is compiled in accordance with part B of Annex VII and this documentation or part hereof will be transmitted by post or electronically to a reasoned request by the national authorities.

This partly completed machinery must not be put into service until the final machinery into which it is to be incorporated has been declared in conformity with the provisions of the Machinery Directive 2006/42/EC where appropriate.

Nordborg, 2025-07-04

John Kling

LINAK A/S

John Kling, B.Sc.E.E., Certification and Regulatory Affairs

Authorised to compile the relevant technical documentation

ATEX/IECEX/CCC certified

LA36 can be ordered in an Ex certified version designed for installation in dust-filled atmospheres, such as grain handling facilities, cement plants, saw mills and other dusty surroundings.



Please note: The approval is for dust only, NOT for gas.

The LA36 with ATEX approval is only available with housing option 'T', 12/24/36V DC motor and flying leads cables.

For limitations and ordering see 'Ordering Example'.

The ATEX/IECEX/CCC versions are suitable for applications in Group IIIC, Category 2D. Zone 21 and 22. Certified according to EN60079-0:2012 and EN60079-31:2014.



Designed in Denmark
DK - 6430 Nordborg

Type : 361203000001BT-655F30489NCS000

Item No. : J70026

Prod. Date : 2025.08.20

Max Load : Push 2600 N / Pull 2600 N IP66

Power Rate : 24 V[±], Max. 13.0 A / Max. 13.0 A

Duty Cycle : 20 %, Max. 4 min./16 min.

NOT TO BE OPENED BY UNAUTHORIZED PERSONNEL
NE PAS OUVRIR PAR DU PERSONNEL NON AUTORISE



W/O #-0001 Made in Denmark

CE 2804 II 2D
Ex tb IIIC T135°C Db
Tamb -25°C to +65°C

Certificate no.: TÜV 15 ATEX 143747 X
IECEX TUN 14.0021X

WARNING !

DO NOT OPEN WHEN AN EXPLOSIVE ATMOSPHERE IS PRESENT.
DO NOT SEPARATE WHEN ENERGISED.
DO NOT OPEN WHEN ENERGISED.
POTENTIAL ELECTROSTATIC CHARGING HAZARD :
SEE INSTRUCTIONS !

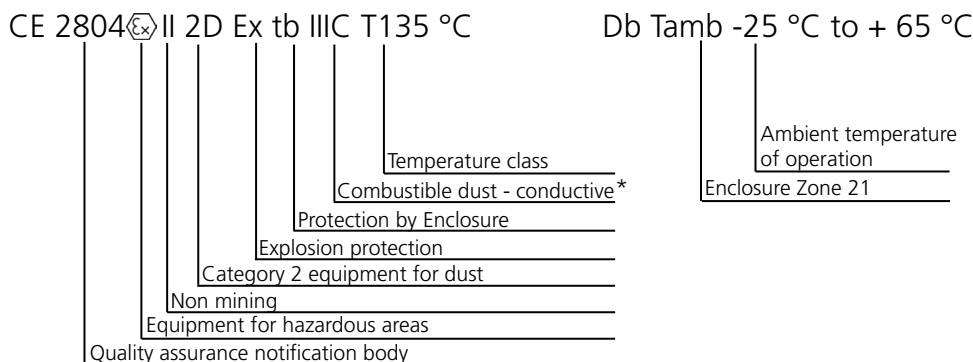

* Not a source of ignition in normal operation or when subjected to faults that may be expected, though not on a regular basis.

ATEX/IECEX/CCC certified

The ATEX/IECEX/CCC versions are suitable for applications in Group IIIC, Category 2D. E.g. Zone 21 and 22 with the following markings:

ATEX: II 2D Ex tb IIIC T135°C dB

IECEX: EX tb IIIC T135°C dB

CCC: Ex tb T135°C dB



Special conditions for use as stated in the certificates:

1. The max duty cycle specified at an ambient temperature of +25 °C.

Load 0-6800 [N]	
Stroke:	Duty cycle:
0-600 mm	20 % int. - Max. 2 [min.] continuous drive followed by 8 [min.] rest.
601-1000 mm	15 % int. - Max. 3 [min.] continuous drive followed by 19 [min.] rest.

Load 10000 [N]	
Stroke:	
0-1000 [mm]	5 % int. - Max. 1 [min.] continuous drive followed by 8 [min.] rest.

2. Ambient temperature area are specified to -25 °C...+65 °C.
3. The power supply cable is of special design fulfilling IP 6X ingress protection. The cable can be delivered in different lengths. Only cables delivered by LINAK A/S shall be mounted.
4. The connection between the actuator and the rest of the machine/device shall be conductive, and furthermore the application shall be grounded in order to remove any Electro Static Discharge. This counts for both of the actuator's fixation points (Back Fixture and Piston Rod Eye).
5. The cable is not UV-resistant and shall be protected from direct sunlight.
6. The supply has to be protected by a fuse according to the electrical data.
7. The Linear Actuator has to be installed in such a way, that highly effective potential electrostatic charges are prevented. The cleaning of the Linear Actuator shall be done only with a damp cloth.

Warning

If the following is not complied with, the ATEX/IECEX/CCC certification will not be valid:

- Actuator use must be in compliance with specification.
- If the actuator has no built-in current cut-off, one must be mounted (Please see the Max current on the type-plate placed on the actuator)
- Only ATEX/IECEX/CCC approved cables are to be used:

Cable type	No of wires in cable	LA36 ATEX/IECEX/CCC cable	Length (mm) outside actuator
Power cable	2 x 14 AWG	0367115-xxxx	1,500 / 5,000 / 10,000 mm
Signal cable	6 x 20 AWG	0367114-xxxx	1,500 / 5,000 / 10,000 mm
Signal cable	9 x 20 AWG	0367399-xxxx	1,500 / 5,000 / 10,000 mm

- The power supply/signal cables for the actuator must be terminated in a safe location or alternatively by use of an Ex terminal box certified for special conditions for safe use
- When mounting or if changing cables in ATEX/IECEX/CCC approved applications, the standard EN IEC 60079-19 must be respected to maintain the certification. It is crucial that a proper tightness is obtained after installing/replacing the cables, therefore the installation guideline below must be strictly followed
- The actuator is not to be opened in areas with dust, and unauthorized personnel is never to produce, modify or repair actuators in order to sustain the approval
- No changes are to be made to the actuator after delivery. This manual is part of the equipment. LINAK A/S keeps the right to modify specifications without advanced notice. Spare this manual for later use

Max fuse for ATEX/IECEX/CCC actuators

Type	Spindle Pitch (mm)	Load max. Push/Pull (N)	Typical Amp. at full load			Max fuse		
			36 V	(A) 24 V	12 V	36 V	(A) 24 V	12 V
36080xxxxxxAxxxxH...	8	6800			17.0			22
36120xxxxxxAxxxxF...	12	2600	-	-	21.0	-	-	22
36120xxxxxxAxxxxG...	12	4500	-	-	20.7	-	-	22
36120xxxxxxAxxxxH...	12	6800	-	-	21.0	-	-	22
36200xxxxxxAxxxxF...	20	1700	-	-	22.0	-	-	22
36200xxxxxxAxxxxE...	20	500	-	-	20.0	-	-	22
36080xxxxxxBxxxxH...	8	6800		8.0			11	
36120xxxxxxBxxxxF...	12	2600	-	10.4	-	-	11	-
36120xxxxxxBxxxxG...	12	4500	-	10.2	-	-	11	-
36120xxxxxxBxxxxH...	12	6800	-	10.3	-	-	11	-
36200xxxxxxBxxxxF...	20	1700	-	10.3	-	-	11	-
36200xxxxxxBxxxxE...	20	500	-	10.0	-	-	11	-
36080xxxxxxCxxxxH...	8	6800	6.5			8		
36120xxxxxxCxxxxF...	12	2600	8.0	-	-	8	-	-
36120xxxxxxCxxxxG...	12	4500	8.0	-	-	8	-	-
36120xxxxxxCxxxxH...	12	6800	8.0	-	-	8	-	-
36200xxxxxxCxxxxF...	20	1700	8.0	-	-	8	-	-
36200xxxxxxCxxxxE...	20	500	8.0	-	-	8	-	-

The product may only be used if:

1. The product is used under the conditions described in the installation - and operation instruction
2. Special conditions for safe use are obtained (see above)
3. Atmospheric conditions: Pressure 80 kPa (0.8 bar) to 110 kPa (1.1 bar); and air with normal oxygen content, typically 21% v/v
4. Safety and operation instructions are accessible and followed
5. The production of ATEX/IECEX/CCC actuators require quality management systems and auditing. Therefore, only LINAK A/S is allowed to produce, modify or repair actuators in order to sustain the certification.

ATEX/IECEX/CCC**General indication of risk:**

Installation of the device shall be performed by trained staff only, familiar with the safety requirements and risks. The installation shall be according to EN IEC 60079-14 and all local safety regulations shall be complied with.

Prevent failures, protect persons against injuries and protect the device against damage.

The person responsible for the system must secure that:

- Safety and operation instructions are accessible and followed
- Local safety regulations and standards are obeyed
- Performance data and installation specifications are complied with
- Safety devices are installed correctly and recommended maintenance is performed
- National regulations for disposal of electrical equipment are obeyed

Maintenance and repair

- Repairs of the device must be carried out by LINAK® authorized persons only or by authorised repair shop fulfilled EN IEC 60079-19
- Only perform mounting as described as in this manual

During maintenance regard all safety regulations and internal operation instructions.

Mounting and replacement of ATEX cables

When mounting the necessary ATEX-approved cables on an ATEX certified LINAK actuator, it is important that this is done carefully by a competent person, in order to protect the plugs and pins -and ensuring the ingress protection of the product. Before the new cable is mounted, the socket shall be greased with Vaseline®, to maintain the high ingress protection and ensuring easy mounting. The plug shall be in the right location and fully pressed in before the cable lid is mounted.

Please note that if the cables are mounted and dismantled more than 3 times the plugs can be damaged. Therefore, such cables shall be discarded and replaced.

Also note that the actuator must not be carried in the cables.

We recommend to take some precaution and design the wire connection in a way, where the cable end is kept inside a closed, protected area to guarantee the high IP protection.

Replacing an ATEX cable



Right side: Powerplug (0363106)
 Middle: Screw (0002267)
 Left side: Signal plug (0363105)

The colour of the O-ring has to be **brown** (see picture) to be used in ATEX certified installations. O-rings with other colours, such as yellow, are not allowed.



Right side: Power cable (0367115-xxxx)
 Middle: Screw (0002267)

Left side: Signal cable (0367114-xxxx) or (0367399-xxxx)

The colour of the O-ring has to be brown (see picture) to be used in ATEX certified installations. O-rings with other colours, such as yellow, are not allowed.



Fixate the actuator.

Loosen the screw to disassemble the cable relief.



Remove the cable relief by pulling it in the actuators stroke direction.



Remove the plugs or cables.



Insert the cables (0367115-xxxx) and (0367114-xxxx or 0367399-xxxx) with ATEX approved O-ring.

The colour of the O-ring has to be **Brown**.

Replacing an ATEX cable



Correct mounting of cables,
The brown O-ring may not be visible.



Incorrect mounting
The brown O-ring is visible
The application is NOT tight



Incorrect mounting
The brown O-ring is visible
The application is NOT tight



Place the cable relief at the top
of the outer tube and slide it all
the way down to the housing.



Place and tighten the screw (0002267).
Fasten it to $3 \text{ Nm} \pm 0,5 \text{ Nm}$



Translation

(1) EU-Type Examination Certificate

- (2) Equipment and protective systems intended for use in potentially explosive atmospheres, **Directive 2014/34/EU**

- (3) **Certificate Number** **TÜV 15 ATEX 143747 X** **Issue:** 01
- (4) for the product: Linear Actuator, Model: LA36 series
- (5) of the manufacturer: **LINAK A/S**
- (6) Address: Smedevænget 8, Guderup
6430 Nordborg
Denmark

Order number: 8003069468

Date of issue: See date of signature

- (7) The design of this product and any acceptable variation thereto are specified in the schedule to this EU-Type Examination Certificate and the documents therein referred to.
- (8) The TÜV NORD CERT GmbH, Notified Body No. 0044, in accordance with Article 17 of the Directive 2014/34/EU of the European Parliament and the Council of 26 February 2014, certifies that this product has been found to comply with the Essential Health and Safety Requirements relating to the design and construction of products intended for use in potentially explosive atmospheres given in Annex II to the Directive.
The examination and test results are recorded in the confidential ATEX Assessment Report No. 24 203 369426.
- (9) Compliance with the Essential Health and Safety Requirements has been assured by compliance with:

EN IEC 60079-0:2018/AC:2020-02

EN 60079-31:2014

except in respect of those requirements listed at item 18 of the schedule.

- (10) If the sign "X" is placed after the certificate number, it indicates that the product is subject to the Specific Conditions for Use specified in the schedule to this certificate.
- (11) This EU-Type Examination Certificate relates only to the design, and construction of the specified product. Further requirements of the Directive apply to the manufacturing process and supply of this equipment. These are not covered by this certificate.
- (12) The marking of the product shall include the following:

 **II 2 D Ex tb IIIC T135 °C Db**

TÜV NORD CERT GmbH, Am TÜV 1, 45307 Essen, notified by the central office of the countries for safety engineering (ZLS), Ident. Nr. 0044, legal successor of the TÜV NORD CERT GmbH & Co. KG Ident. Nr. 0032

The head of the notified body

 Digital unterschrieben
von Roder Christian
Datum: 2024.11.11
22:13:31 +01'00'

Hanover office, Am TÜV 1, 30519 Hannover, Tel. +49 511 998-61455, Fax +49 511 998-61590

This certificate may only be reproduced without any change, schedule included.
Excerpts or changes shall be allowed by the TÜV NORD CERT GmbH



(13) **SCHEDULE**

(14) **EU-Type Examination Certificate TÜV 15 ATEX 143747 X Issue 01**

(15) Description of product

The LA36 series of linear actuators creates motion in a straight line, as contrasted with circular motion of a conventional electric motor. The actuator consists of a motor, a gearbox and a spindle that causes the actuator to either extend or retract. The motor housing consists of a two-part aluminium assembly with a cork gasket and an aluminium outer tube. The equipment is earthed externally through actuators fixation points: the piston rod eye and the back fixture. The actuators are rated for 12V, 24V or 36V d.c. with push / pull specifications up to 10000 N.

Type key:

The LA36 series of linear actuators can be delivered in different type variants in accordance with the manufacturers ordering nomenclature (below). The different type variants, which does not involve the design of the motor housing itself, has no influence on the Ex-protection principle Ex tb IIIC T135 °C Db as long as the supplied power cable are delivered by the manufacturer.

Model LA36 can furthermore be delivered with an accessory, called “Rodent protection”. This variant is mounted with an external cable gland for mechanical fixing of a cable conduit, to make the power and signal cable rodent protected. This external cable gland has no influence on the Ex-protection principle and the ingress protection is still kept IP6x.

Actuator type	Spindle Pitch	Stroke length	Safety	Feedback	Platform	Motor type	IP degree		Colour	Back fixture	Piston rod eye	Gear	Brake	BID	Fire category	Plug type	Cable	Safety factor	Not specified	Not used	
36	***	***	*	*	**	*	*	-	*	*	*	*	*	****	*	*	*	*	*	*	

The actuators are certified under the type LA36 including various type variants which has no influence on the ingress protection / Ex-protection principle. The manufacturers “Scheduled Drawings” specify the fixed part of the construction.

Electrical data:

Supply (brown and blue)

Type 1 $U_n = 12 \text{ V d.c.} + 20\%$
 $I_n = 22 \text{ A}$

Type 2 $U_n = 24 \text{ V d.c.} + 10\%$
 $I_n = 11 \text{ A}$

Type 3 $U_n = 36 \text{ V d.c.} + 10\%$
 $I_n = 8 \text{ A}$

Signal Power supply (red and black)

$U_n = 12 - 24 \text{ V d.c.}$
 $I_n = 40 \text{ mA}$

This certificate may only be reproduced without any change, schedule included.
 Excerpts or changes shall be allowed by the TÜV NORD CERT GmbH



Schedule to EU-Type Examination Certificate TÜV 15 ATEX 143747 X Issue 01

Thermal data:

The permissible ambient temperature range during operation is -25 °C ... +65 °C.

(16) Drawings and documents are listed in the ATEX Assessment Report No. 24 203 369426.

(17) Specific Conditions for Use

1. The max duty cycle specified at an ambient of +25 °C.

LOAD 0-6800 [N]	
STROKE	DUTY CYCLE
0-600 [mm]	20% int. - Max. 2 [min.] continuous drive followed by 8 [min.] rest.
600-1000 [mm]	15% int. - Max. 3 [min.] continuous drive followed by 17 [min.] rest.

LOAD 10000 [N]	
STROKE	DUTY CYCLE
0-1000 [mm]	5% int. - Max. 1 [min.] continuous drive followed by 19 [min.] rest.

2. Ambient temperature area is specified to -25 °C ... +65 °C.
3. The power supply cable is of special design fulfilling IP 6X ingress protection. The cable can be delivered in different lengths. Only cables delivered by Linak shall be mounted.
4. The connection between the actuator and the rest of the machine/device shall be conductive, and furthermore the application shall be grounded in order to remove any Electrostatic Discharge. This counts for both of the actuator's fixation points (Back Fixture and Piston Rod Eye).
5. The cable is not UV-resistant and shall be protected from direct sunlight.
6. The supply has to be protected by a fuse according to the electrical data.
7. The Linear Actuator has to be installed in such a way, that highly effective potential electrostatic charges are prevented. The cleaning of the Linear Actuator shall be done only with a damp cloth.

(18) Essential Health and Safety Requirements

No additional ones

- End of EU-Type Examination Certificate -

This certificate may only be reproduced without any change, schedule included.
Excerpts or changes shall be allowed by the TÜV NORD CERT GmbH



IECEx Certificate of Conformity

Certificate No.: IECEx TUN 14.0021X

Date of Issue: 2016-02-24

Issue No.: 1

Page 2 of 5

Manufacturer: **Linak A/S**
Smedevænget 8, Guderup
6430 Nordborg
Denmark

Additional Manufacturing location
(s):

This certificate is issued as verification that a sample(s), representative of production, was assessed and tested and found to comply with the IEC Standard list below and that the manufacturer's quality system, relating to the Ex products covered by this certificate, was assessed and found to comply with the IECEx Quality system requirements. This certificate is granted subject to the conditions as set out in IECEx Scheme Rules, IECEx 02 and Operational Documents as amended.

STANDARDS:

The electrical apparatus and any acceptable variations to it specified in the schedule of this certificate and the identified documents, was found to comply with the following standards:

IEC 60079-0 : 2011 Explosive atmospheres - Part 0: General requirements
Edition: 6.0

IEC 60079-31 : 2013 Explosive atmospheres - Part 31: Equipment dust ignition protection by enclosure "t"
Edition: 2

*This Certificate **does not** indicate compliance with electrical safety and performance requirements other than those expressly included in the Standards listed above.*

TEST & ASSESSMENT REPORTS:

A sample(s) of the equipment listed has successfully met the examination and test requirements as recorded in

Test Report:

[DE/TUN/ExTR14.0044/01](#)

[DE/TUN/ExTR14.0044/00](#)

Quality Assessment Report:

[SE/SP/QAR14.0001/02](#)



IECEX Certificate of Conformity

INTERNATIONAL ELECTROTECHNICAL COMMISSION IEC Certification System for Explosive Atmospheres

for rules and details of the IECEx Scheme visit www.iecex.com

Certificate No.:	IECEX TUN 14.0021X	Page 1 of 5	<u>Certificate history:</u>
Status:	Current	Issue No: 2	Issue 1 (2016-02-24) Issue 0 (2015-10-13)
Date of Issue:	2024-12-19		
Applicant:	Linak A/S Smedevænget 8, Guderup 6430 Nordborg Denmark		
Equipment:	Actuator type LA36		
Optional accessory:			
Type of Protection:	Protection by enclosure "tb"		
Marking:	Ex tb III C T135 °C Db		

Approved for issue on behalf of the IECEx
Certification Body:

Christian Roder

Position:

Head of IECEx Certification Body

Signature:
(for printed version)

TUVNORD

Digital unterschrieben
von Roder Christian
Datum: 2024.12.19
23:02:50 +01'00'

Date:
(for printed version)

1. This certificate and schedule may only be reproduced in full.
2. This certificate is not transferable and remains the property of the issuing body.
3. The Status and authenticity of this certificate may be verified by visiting www.iecex.com or use of this QR Code.



Certificate issued by:

TÜV NORD CERT GmbH
Hanover Office
Am TÜV 1, 30519 Hannover
Germany





IECEX Certificate of Conformity

Certificate No.: **IECEX TUN 14.0021X**

Page 2 of 5

Date of issue: 2024-12-19

Issue No: 2

Manufacturer: **Linak A/S**
Smedevænget 8, Guderup
6430 Nordborg
Denmark

Manufacturing
locations:

This certificate is issued as verification that a sample(s), representative of production, was assessed and tested and found to comply with the IEC Standard list below and that the manufacturer's quality system, relating to the Ex products covered by this certificate, was assessed and found to comply with the IECEX Quality system requirements. This certificate is granted subject to the conditions as set out in IECEX Scheme Rules, IECEX 02 and Operational Documents as amended

STANDARDS :

The equipment and any acceptable variations to it specified in the schedule of this certificate and the identified documents, was found to comply with the following standards

[IEC 60079-0:2017](#) Explosive atmospheres - Part 0: Equipment - General requirements
Edition:7.0

[IEC 60079-31:2022](#) Explosive atmospheres – Part 31: Equipment dust ignition protection by enclosure "t"
Edition:3.0

This Certificate **does not** indicate compliance with safety and performance requirements other than those expressly included in the Standards listed above.

TEST & ASSESSMENT REPORTS:

A sample(s) of the equipment listed has successfully met the examination and test requirements as recorded in:

Test Report:

[DE/TUN/ExTR14.0044/02](#)

Quality Assessment Report:

[GB/EXV/QAR22.0016/01](#)



IECEX Certificate of Conformity

Certificate No.: **IECEX TUN 14.0021X**

Page 3 of 5

Date of issue: 2024-12-19

Issue No: 2

EQUIPMENT:

Equipment and systems covered by this Certificate are as follows:

The LA36 series of linear actuators creates motion in a straight line, as contrasted with circular motion of a conventional electric motor. The actuator consists of a motor, a gearbox and a spindle that causes the actuator to either extend or retract. The motor housing consists of a two-part aluminium assembly with a cork gasket and an aluminium outer tube. The equipment is earthed externally through actuators fixation points: the piston rod eye and the back fixture. The actuators are rated for 12V, 24V or 36V d.c. with push / pull specifications up to 10000 N.

Model LA36 can furthermore be delivered with an accessory, called "Rodent protection". This variant is mounted with an external cable gland for mechanical fixing of a cable conduit, to make the power and signal cable rodent protected. This external cable gland has no influence on the Ex-protection principle and the ingress protection is still kept IP6x.

The actuators are certified under the type LA36 including various type variants which has no influence on the ingress protection / Ex-protection principle. The manufacturers "Scheduled Drawings" specify the fixed part of the construction.

Supply (brown and blue)

Type 1	U_n	=	12	V d.c.	$\pm 20\%$
	I_n	=	22	A	

Type 2	U_n	=	24	V d.c.	$\pm 10\%$
	I_n	=	11		

Type 3	U_n	=	36	V d.c.	$\pm 10\%$
	I_n	=	8	A	

Signal Power supply (red and black)

U_n	=	12 - 24	V d.c.
I_n	=	40	mA

SPECIFIC CONDITIONS OF USE: YES as shown below:

1. The max. duty cycle is specified as follows at an ambient temperature of +25 °C:

LOAD 0-6800 [N]		DUTY CYCLE
STROKE		
0-600 [mm]		20% int. - Max. 2 [min.] continuous drive followed by 8 [min.] rest.
600-1000 [mm]		15% int. - Max. 3 [min.] continuous drive followed by 17 [min.] rest.

LOAD 10000 [N]		DUTY CYCLE
STROKE		
0-1000 [mm]		5% int. - Max. 1 [min.] continuous drive followed by 19 [min.] rest.

2. Ambient temperature area is specified to -25 °C to + 65 °C

3. The power supply cable is of special design fulfilling IP 6X ingress protection. The cable can be delivered in different lengths. Only cables delivered by LINAK A/S must be mounted.



IECEX Certificate of Conformity

Certificate No.: **IECEX TUN 14.0021X**

Page 4 of 5

Date of issue: 2024-12-19

Issue No: 2

4. The connection between the actuator and the rest of the machine/device shall be conductive, and furthermore the application shall be grounded in order to remove any Electro Static Discharge. This counts for both of the actuator's fixation points (Back Fixture and Piston Rod Eye).

5. The cable is not UV-resistant and shall be protected from direct sunlight.

6. The supply has to be protected by a fuse according to the electrical data.

7. The Linear Actuator has to be installed in such a way, that highly effective potential electrostatic charges are prevented. The cleaning of the Linear Actuator shall be done only with a damp cloth.



IECEX Certificate of Conformity

Certificate No.: **IECEX TUN 14.0021X**

Page 5 of 5

Date of issue: 2024-12-19

Issue No: 2

DETAILS OF CERTIFICATE CHANGES (for issues 1 and above)

- Proof of conformity to the current standards IEC 60079-0:2017 and IEC 60079-31:2022
- Updating drawings
- New signal cable (0367399-xxxx) has been added.
- Specific Conditions of Use extended.

Annex:

[Attachment to IECEx TUN 14.0021X issue No. 02.pdf](#)

TÜV NORD CERT GmbH
Hannover Office
Am TÜV 1
30519 Hannover
Germany



Page 1 of 3
Attachment to IECEx TUN 14.0021X issue No.: 02

Product:

The LA36 series of linear actuators creates motion in a straight line, as contrasted with circular motion of a conventional electric motor. The actuator consists of a motor, a gearbox and a spindle that causes the actuator to either extend or retract. The motor housing consists of a two-part aluminium assembly with a cork gasket and an aluminium outer tube. The equipment is earthed externally through actuators fixation points: the piston rod eye and the back fixture. The actuators are rated for 12V, 24V or 36V d.c. with push / pull specifications up to 10000 N.

Type key:

LA 36 series

Type variants:

The LA36 series of linear actuators can be delivered in different type variants in accordance with the manufacturers ordering nomenclature (below). The different type variants, which does not involve the design of the motor housing itself, has no influence on the Ex-protection principle Ex tb IIIC T135 °C Db as long as the supplied power cable are delivered by the manufacturer.

Model LA36 can furthermore be delivered with an accessory, called “Rodent protection”. This variant is mounted with an external cable gland for mechanical fixing of a cable conduit, to make the power and signal cable rodent protected. This external cable gland has no influence on the Ex-protection principle and the ingress protection is still kept IP6x.

Actuator type	Spindle Pitch	Stroke length	Safety	Feedback	Platform	Motortype	IP degree		Colour	Back fixture	Piston rod eye	Gear	Brake	BID	Fire category	Plug type	Cable	Safety factor	Not specified	Not used	
36	***	***	*	*	*	*	*	-	*	*	*	*	*	****	*	*	*	*	*	*	

The actuators are certified under the type LA36 including various type variants which has no influence on the ingress protection / Ex-protection principle. The manufacturers “Scheduled Drawings” specify the fixed part of the construction.

Electrical data:

Supply (brown and blue)

Type 1 $U_n = 12 \text{ V d.c.} + 20\%$
 $I_n = 22 \text{ A}$

Type 2 $U_n = 24 \text{ V d.c.} + 10\%$
 $I_n = 11 \text{ A}$

Type 3 $U_n = 36 \text{ V d.c.} + 10\%$
 $I_n = 8 \text{ A}$

Signal Power supply (red and black)

$U_n = 12 - 24 \text{ V d.c.}$
 $I_n = 40 \text{ mA}$

TÜV NORD CERT GmbH
Hannover Office
Am TÜV 1
30519 Hannover
Germany



Page 2 of 3
Attachment to IECEx TUN 14.0021X issue No.: 02

Thermal data:

Permissible range of ambient temperature during operation: -25 °C ... +65 °C

Details of Change:

- Proof of conformity to the current standards IEC 60079-0:2017 and IEC 60079-31:2022
- Updating drawings
- New signal cable (0367399-xxxx) has been added.
- Specific Conditions of Use extended.

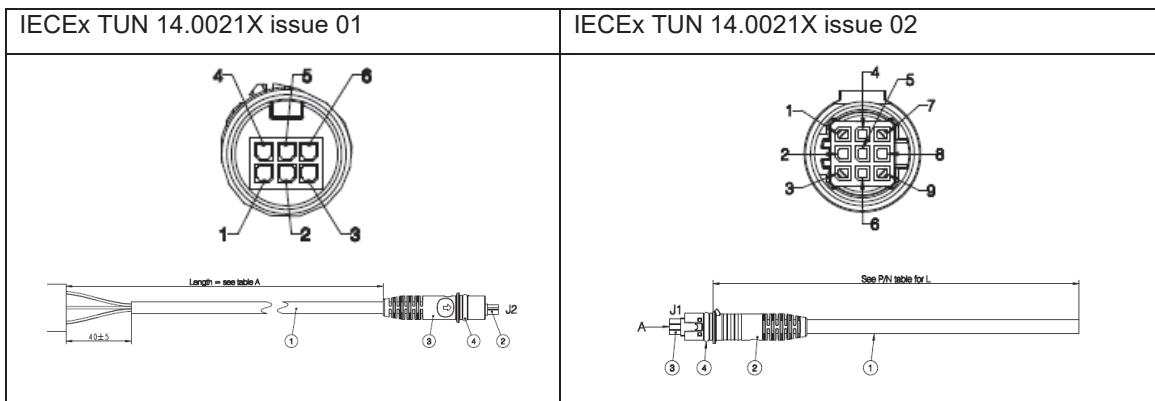

Special Conditions for Safe Use / Notes for Erection:

1. The max duty cycle specified at an ambient of +25 °C.

LOAD 0-6800 [N]	
STROKE	DUTY CYCLE
0-600 [mm]	20% int. - Max. 2 [min.] continuous drive followed by 8 [min.] rest.
600-1000 [mm]	15% int. - Max. 3 [min.] continuous drive followed by 17 [min.] rest.

LOAD 10000 [N]	
STROKE	DUTY CYCLE
0-1000 [mm]	5% int. - Max. 1 [min.] continuous drive followed by 19 [min.] rest.

2. Ambient temperature area is specified to -25 °C ... +65 °C.
3. The power supply cable is of special design fulfilling IP 6X ingress protection. The cable can be delivered in different lengths. Only cables delivered by Linak shall be mounted.
4. The connection between the actuator and the rest of the machine/device shall be conductive, and furthermore the application shall be grounded in order to remove any Electro Static Discharge. This counts for both of the actuator's fixation points (Back Fixture and Piston Rod Eye).

TÜV NORD CERT GmbH
Hannover Office
Am TÜV 1
30519 Hannover
Germany



Page 3 of 3
Attachment to IECEx TUN 14.0021X issue No.: 02

5. The cable is not UV-resistant and shall be protected from direct sunlight.
6. The supply has to be protected by a fuse according to the electrical data.
7. The Linear Actuator has to be installed in such a way, that highly effective potential electrostatic charges are prevented. The cleaning of the Linear Actuator shall be done only with a damp cloth.



CERTIFICATE FOR CHINA COMPULSORY PRODUCT CERTIFICATION

No.: 2021312307000228

Applicant	LINAK (SHENZHEN) ACTUATOR SYSTEMS LTD.
Address	Block B, Shanghe Industrial Park, Nanchang Road, Xixiang Street, Bao'an District, Shenzhen
Manufacturer	Linak A/S
Address	Smedevænget 8, Guderup, 6430 Nordborg, Denmark
Production Factory	Linak A/S
Production Address	Smedevænget 8, Guderup, 6430 Nordborg, Denmark
Product	Actuator
Model/Type	36XXX XXX X X XX X T - X X X X X XXXX X X X X X X
Ex marking	Ex tb IIIC T135°C Db
Reference Standards	GB/T3836.1-2021, GB/T3836.31-2021

Certification mode Type Test + Initial Factory Inspection + Post-Certification Surveillance

The product(s) is verified and certified according to CNCA-C23-01: 2019 *China Compulsory Certification Implementation Rule on Explosion Protected Electrical Product* and CNEX-C2301-2019 *Guideline of China Compulsory Certification Implementation Rule on Explosion Protected Electrical Product*.

See Annex for the detailed product information (6 pages).

Initial issue date: 2022-01-13

Issued date: 2023-01-13

Valid to: 2027-01-12

The validity of this certificate is maintained through the regular supervision of the issuing authority during the validity period.

Where any discrepancy arises between the English translation and the original Chinese version, the Chinese version shall prevail.

Director:



Nanyang Explosion Protected Electrical
Apparatus Research Institute Co., Ltd.



<http://www.ccc-cnex.com>
ccc.china-ex.com

Add: No. 20, North Zhongjing Road, Nanyang, Henan, P. R. China
Tel: 0377-63239734

P.C.: 473008
Email: ccc@cn-ex.com

CN 0001553



CERTIFICATE FOR CHINA COMPULSORY PRODUCT CERTIFICATION (Annex)

No.: 2021312307000228

Page 1 of 6

Product information:

1. This certificate covers the following models:

- 36XXX XXX X X XX X T - X X X X X XXXX X X X X X X

3	X	X	X	X	X	X	T	-	X	X	X	X	X	X	X	X	X	X	X	
6	X	X			X															
	X	X																		
a	b	c	d	e	f	g	h		i	j	k	l	m	n	o	p	q	r	s	t

- a: Actuator Type 36=LA36
- b: Spindle Pitch
080=8mm
120=12mm
160=16mm
200=20mm
- c: Stroke Length, mm (50-1200mm)
XXX=≤999
AXX=10XX
BXX=11XX
CXX=12XX
- d: Safety
0 = None
A = Safety nut
- e: Feedback
0=None
A=Hall Potentiometer
F=PWN
H=Dual Hall
K=Single Hall
L=Potentiale free endstop signals

Issued date: 2023-01-13

Director:



Nanyang Explosion Protected Electrical
Apparatus Research Institute Co.,Ltd.



<http://www.ccc-cnex.com> Add: No. 20, North Zhongjing Road, Nanyang, Henan, P. R. China P.C.: 473008
ccc.china-ex.com Tel: 0377-63239734 Email: ccc@cn-ex.com



CERTIFICATE FOR CHINA COMPULSORY PRODUCT CERTIFICATION (Annex)

No.: 2021312307000228

Page 2 of 6

P=Potmeter (only standard)
X=Special

f: Platform

00=Standard (Without Limit Switches)
01=Standard ((With Limit Switches)
13=IC Basic
23=IC Advanced
33=IC Parallel
04=MODBUS
06=LINBUS Switch
16=LINBUS Zero point
07=CANBUS(J19390 Switch
17=CANBUS(J1939) Zero point
08=CANBUS(CANOPEN) Switch
XX=Special

g: Motor Type

A=12VDC Normal	1=12VDC with dummy clutch
B=24VDC Normal	2=24VDC with dummy clutch
C=36VDC Normal	3=36VDC with dummy clutch
J=48VDC Normal	4=48VDC with dummy clutch
X=Other	

h: IP degree IP6X

i: Colour

6=Dark Olivish Grey NCS S7000-N
X=Special

j: Back fixture

1=0 degrees	3=Ball Eye
2=90 degrees	4=Outer thread
A=30 degrees	5=Inner thread
B=60 degrees	6=Rotated (interval 30°)
C=120 degrees	X=Special

Issued date: 2023-01-13

Director:



Nanyang Explosion Protected Electrical
Apparatus Research Institute Co.,Ltd.



<http://www.ccc-cnex.com>
ccc.china-ex.com

Add: No. 20, North Zhongjing Road, Nanyang, Henan, P. R. China
Tel: 0377-63239734

P.C.: 473008

Email: ccc@cn-ex.com



CERTIFICATE FOR CHINA COMPULSORY PRODUCT CERTIFICATION (Annex)

No.: 2021312307000228

Page 3 of 6

D=150 degrees

k: Piston Rod Eye orientation

1=With slot	2=Solid
4=Outer thread	5=Inner thread
6=Ball eye	X=Special

l: Gear

E=Gear ratio 1: 7 (F-Gear)
 F=Gear ratio 1: 18 (A-Gear)
 G=Gear ratio 1: 31 (B-Gear)
 H=Gear ratio 1: 46 (C-Gear)

m: Brake

1=Push
 2=Pull
 3=Push/Pull

n: BID (min 0300)

XXXX = 4 digits could be any number

o: FIRE CATEGORY(not affecting Ex performance)

A=A_HIGH / A_HIGH
 B=A_LOW / A_HIGH
 C=A_HIGH / A_LOW
 D=A_LOW / A_LOW
 E=LOW / A_HIGH
 F=HIGH / A_HIGH
 G=LOW / A_LOW
 H=HIGH / A_LOW
 J=A_HIGH / LOW
 K=A_LOW / LOW
 L=A_HIGH / HIGH
 M=A_LOW / HIGH
 N=LOW / LOW
 O=HIGH / LOW

Issued date: 2023-01-13

Director:



Nanyang Explosion Protected Electrical
 Apparatus Research Institute Co.,Ltd.



<http://www.ccc-cnex.com>
ccc.china-ex.com

Add: No. 20, North Zhongjing Road, Nanyang, Henan, P. R. China P.C.: 473008
 Tel: 0377-63239734

Email: ccc@cn-ex.com



CERTIFICATE FOR CHINA COMPULSORY PRODUCT CERTIFICATION (Annex)

No.: 2021312307000228

Page 4 of 6

P=LOW / HIGH
Q=HIGH / HIGH
X=special

p: Plug Type
U=Power cable UL1203 USA
0=NONE
C=Flying leads
H=AMP
K=AMP Super Seal
J=Deutsch
7=AMP Super Seal - Moulded
9=Deutsch Moulded
X=Special

q: Cable
0=None
A=90° angled connectors
S=Straight
Y=Y-Cable
X=Special

r: Safety factor
0=standard

s: SW Configuration (not affecting Ex performance)
0=Standard
X=Special Configuration

t: 0=Not used

The electrical data are as follows:

Supply (brown and blue)		
Type 1	U _n = 12VDC±20%	I _n = 22A
Type 2	U _n = 24VDC±10%	I _n = 11A
Type 3	U _n = 36VDC±10%	I _n = 8A

Issued date: 2023-01-13

Director:



Nanyang Explosion Protected Electrical
Apparatus Research Institute Co.,Ltd.



http://www.ccc-cnex.com
ccc.china-ex.com

Add: No. 20, North Zhongjing Road, Nanyang, Henan, P. R. China
Tel: 0377-63239734

P.C.: 473008
Email: ccc@cn-ex.com



CERTIFICATE FOR CHINA COMPULSORY PRODUCT CERTIFICATION (Annex)

No.: 2021312307000228

Page 5 of 6

Signal Power supply (red and black)	
U _n = 12 - 24VDC	I _n = 40mA

Ex marking: Ex tb IIIC T135°C Db

- Producers should organize production in accordance with the technical documents approved by the certification body.

2. Specific conditions of safety use:

- Ingress protection: IP6X.
- Ambient temperature range is specified to -25°C to +65°C.
- The max. duty cycle is specified as follows at an ambient temperature of +25°C:

LOAD 0-6800N	
STROKE	DUTY CYCLE
0-600mm	20% int. - Max. 2 [min.] continuous drive followed by 8 [min.] rest.
600-1000mm	15% int. - Max. 3 [min.] continuous drive followed by 17 [min.] rest.

LOAD 10000N	
STROKE	DUTY CYCLE
0-1000mm	5% int. - Max. 1 [min.] continuous drive followed by 19 [min.] rest.

- The power supply cable is of special design fulfilling IP 6X ingress protection. The cable can be delivered in different lengths. Only cables delivered by LINAK A/S shall be mounted.
- The connection between the actuator and the fixing points must be conductive and furthermore the application must be grounded in order to remove any electrostatic charge. This relates to both the fixing point on the motor housing and the point on the piston rod.
- The supply cable must be protected against UV-light.
- The supply must be protected by a fuse according to the electrical data.

Issued date: 2023-01-13

Director:



Nanyang Explosion Protected Electrical
Apparatus Research Institute Co.,Ltd.



http://www.ccc-cnex.com
ccc.china-ex.com

Add: No. 20, North Zhongjing Road, Nanyang, Henan, P. R. China
Tel: 0377-63239734

P.C.: 473008
Email: ccc@cn-ex.com



CERTIFICATE FOR CHINA COMPULSORY PRODUCT CERTIFICATION (Annex)

No.: 2021312307000228

Page 6 of 6

- Warning - DO NOT OPEN WHEN AN EXPLOSIVE ATMOSPHERE IS PRESENT !
 - Warning - DO NOT SEPARATE WHEN ENERGISED !
 - Warning - DO NOT OPEN WHEN ENERGISED !
 - Warning - POTENTIAL ELECTROSTATIC CHARGING HAZARD: SEE INSTRUCTIONS !
 - See instruction for other information.
3. Certificate related report(s):
- Type test report: CQST2107C011, CQST2107C011/01
 - Factory inspection report: CN2021Q010402
4. Certificate change information:
- 1st change on January 13, 2023: Updated the standards for certification.

Issued date: 2023-01-13

Director:



Nanyang Explosion Protected Electrical
Apparatus Research Institute Co.,Ltd.



<http://www.ccc-cnex.com>
ccc.china-ex.com

Add: No. 20, North Zhongjing Road, Nanyang, Henan, P. R. China P.C.: 473008
Tel: 0377-63239734

Email: ccc@cn-ex.com

Contacts

FACTORIES

Denmark - Headquarters
LINAK A/S
Phone: +45 73 15 15 15
Fax: +45 74 45 80 48
Fax (Sales): +45 73 15 16 13
Web: www.linak.com

China
LINAK (Shenzhen) Actuator Systems, Ltd.
Phone: +86 755 8610 6656
Phone: +86 755 8610 6990
Web: www.linak.cn

Slovakia
LINAK Slovakia s.r.o.
Phone: +421 51 7563 444
Web: www.linak.sk

Thailand
LINAK APAC Ltd.
Phone: +66 33 265 400
Web: www.linak.com

USA
LINAK U.S. Inc.
Americas Headquarters
Phone: +1 502 253 5595
Phone: +1 502 253 5596
Web: www.linak-us.com
www.linak-latinamerica.com

SUBSIDIARIES

Australia
LINAK Australia Pty. Ltd
Phone: +61 3 8796 9777
Fax: +61 3 8796 9778
E-mail: sales@linak.com.au
Web: www.linak.com.au

Austria
LINAK Zweigniederlassung - Österreich (Wien)
Phone: +43 (1) 890 7446
Fax: +43 (1) 890 744615
E-mail: info@linak.de
Web: www.linak.at - www.linak.hu

Belgium
LINAK Actuator-Systems NV/SA
(Belgium & Luxembourg)
Phone: +32 (0)9 230 01 09
E-mail: beinfo@linak.be
Web: www.linak.be - www.fr.linak.be

Brazil
LINAK Do Brasil Comércio De Atuadores Ltda.
Phone: +55 (11) 2832 7070
Fax: +55 (11) 2832 7060
E-mail: info@linak.com.br
Web: www.linak.com.br

Canada
LINAK Canada Inc.
Phone: +1 502 253 5595
Fax: +1 416 255 7720
E-mail: info@linak.ca
Web: www.linak-us.com

Czech Republic
LINAK C&S s.r.o.
Phone: +42 058 174 1814
Fax: +42 058 170 2452
E-mail: info@linak.cz
Web: www.linak.cz - www.linak.sk

Denmark - International
LINAK International
Phone: +45 73 15 15 15
E-mail: info@linak.com
Web: www.linak.com

Denmark - Sales
LINAK Danmark A/S
Phone: +45 86 80 36 11
Fax: +45 86 82 90 51
E-mail: linak@linak-silkeborg.dk
Web: www.linak.dk

Finland
LINAK OY
Phone: +358 10 841 8700
E-mail: linak@linak.fi
Web: www.linak.fi

France
LINAK France E.U.R.L
Phone: +33 (0) 2 41 36 34 34
Fax: +33 (0) 2 41 36 35 00
E-mail: linak@linak.fr
Web: www.linak.fr

Germany
LINAK GmbH
Phone: +49 6043 9655 0
Fax: +49 6043 9655 60
E-mail: info@linak.de
Web: www.linak.de

India
LINAK A/S India Liaison Office
Phone: +91 120 4531797
Fax: +91 120 4786428
E-mail: info@linak.in
Web: www.linak.in

Ireland
LINAK UK Limited (Ireland)
Phone: +44 (0)121 544 2211
Fax: +44 (0)121 544 2552
+44 (0)796 855 1606 (UK Mobile)
+35 387 634 6554 (Rep.of Ireland Mobile)
E-mail: sales@linak.co.uk
Web: www.linak.co.uk

Italy
LINAK ITALIA S.r.l.
Phone: +39 02 48 46 33 66
Fax: +39 02 48 46 82 52
E-mail: info@linak.it
Web: www.linak.it

Japan
LINAK K.K.
Phone: 81-45-533-0802
Fax: 81-45-533-0803
E-mail: linak@linak.jp
Web: www.linak.jp

Malaysia
LINAK Actuators Sdn. Bhd.
Phone: +60 4 210 6500
Fax: +60 4 226 8901
E-mail: info@linak-asia.com
Web: www.linak.my

Netherlands
LINAK Actuator-Systems B.V.
Phone: +31 76 5 42 44 40 /
+31 76 200 11 10
E-mail: info@linak.nl
Web: www.linak.nl

New Zealand
LINAK New Zealand Ltd
Phone: +64 9580 2071
Fax: +64 9580 2072
E-mail: nzsales@linak.com.au
Web: www.linak.com.au

Norway
LINAK Norge AS
Phone: +47 32 82 90 90
E-mail: info@linak.no
Web: www.linak.no

Poland
LINAK Polska
LINAK Danmark A/S (Spółka Akcyjna)
Phone: +48 22 295 09 70 /
+48 22 295 09 71
E-mail: info@linak.pl
Web: www.linak.pl

Republic of Korea
LINAK Korea Ltd.
Phone: +82 2 6231 1515
Fax: +82 2 6231 1516
E-mail: info@linak.kr
Web: www.linak.kr

Slovakia
LINAK Slovakia S.R.O.
Phone: +421 51 7563 444
Web: www.linak.sk

Spain
LINAK Actuadores, S.L.u
Phone: +34 93 588 27 77
Fax: +34 93 588 27 85
E-mail: esma@linak.es
Web: www.linak.es

Sweden
LINAK Scandinavia AB
Phone: +46 8 732 20 00
Fax: +46 8 732 20 50
E-mail: info@linak.se
Web: www.linak.se

Switzerland
LINAK AG
Phone: +41 43 388 31 88
Fax: +41 43 388 31 87
E-mail: info@linak.ch
Web: www.linak.ch - www.fr.linak.ch
www.it.linak.ch

Taiwan
LINAK (Shenzhen) Actuator systems Ltd.
Taiwan Representative office
Phone: +886 2 272 90068
Fax: +886 2 272 90096
E-mail: sales@linak.com.tw
Web: www.linak.com.tw

Turkey
LINAK İth. İhr. San. ve Tic. A.Ş.
Phone: +90 312 4726338
Fax: +90 312 4726635
E-mail: info@linak.com.tr
Web: www.linak.com.tr

United Kingdom
LINAK UK Limited
Phone: +44 (0)121 544 2211
Fax: +44 (0)121 544 2552
E-mail: sales@linak.co.uk
Web: www.linak.co.uk

DISTRIBUTORS

Argentina
Novotec Argentina SRL
Phone: 011-4303-8989 / 8900
Fax: 011-4032-0184
E-mail: info@novotecargentina.com
Web: www.novotecargentina.com

Colombia
MEM Ltda
Phone: +[57] (1) 334-7666
Fax: +[57] (1) 282-1684
E-mail: servicioalcliente@memltda.com.co
Web: www.mem.net.co

India
Mechatronics Control Equipments India Pvt Ltd
Phone: +91-44-28558484, 85
E-mail: bala@mechatronicscontrol.com
Web: www.mechatronicscontrol.com

Indonesia
PT. Himalaya Everest Jaya
Phone: +6 221 544 8956 /+6 221 544 8965
Fax: +6 221 619 1925
Fax (Sales): +6 221 619 4658
E-mail: hejplastic-div@centrin.net.id
Web: www.hej.co.id

Israel
NetivTech LTD
Phone: +972 55-2266-535
Fax: +972 2-9900-560
Email: info@NetivTech.com
Web: www.netivtech.com

Singapore
Servo Dynamics Pte Ltd
Phone: +65 6844 0288
Fax: +65 6844 0070
E-mail: servodynamics@servo.com.sg

South Africa
Industrial Specialised Applications CC
Phone: +27 011 466 0346
E-mail: gartht@isagroup.co.za
Web: www.isaza.co.za

United Arab Emirates
Mechatronics
Phone: +971 4 267 4311
Fax: +971 4 267 4312
E-mail: mechtron@emirates.net.ae