

# Lifting Column LC3 – 2-stage and 3-stage Data Sheet

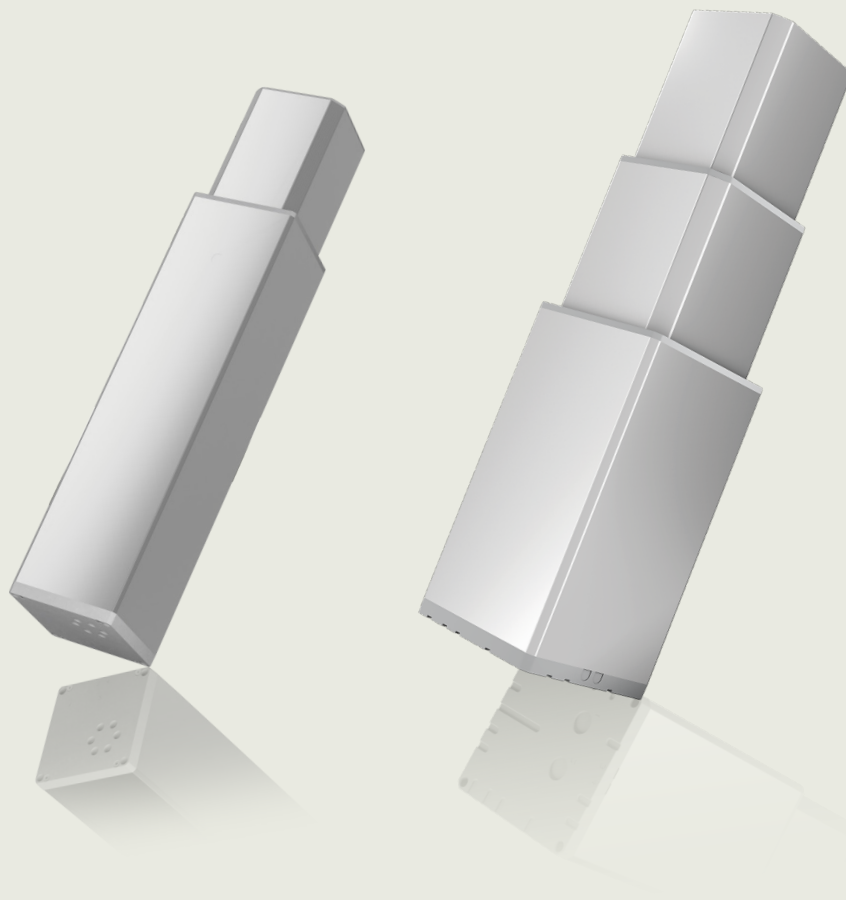

## Contents

<b>Introduction</b> .....	<b>4</b>
<b>Features and options</b> .....	<b>4</b>
<b>Usage</b> .....	<b>5</b>
<b>3-stage installation dimensions</b> .....	<b>6</b>
Standard profile vs stroke length.....	6
Special dimensions.....	6
Static bending moment (Nm).....	6
<b>2-stage installation dimensions</b> .....	<b>7</b>
Standard profile vs stroke length.....	7
Special dimensions.....	7
Static bending moment (Nm).....	7
<b>LC3 safety factor in push and pull</b> .....	<b>8</b>
<b>Ordering example</b> .....	<b>9</b>
<b>Dimensions</b> .....	<b>10</b>
LC3 3-stage.....	10
LC3 2-stage.....	10
<b>LC3 mounting guidelines</b> .....	<b>10</b>
<b>Cable connections overview</b> .....	<b>11</b>
T000.....	11
T001.....	11
T100.....	11
T200.....	12
T030.....	12
T040.....	12
T101.....	13
T201.....	13
T031.....	13
T041.....	14
T110.....	14
T120.....	14
T220.....	15
T130.....	15
T140.....	16
T230.....	16
T240.....	17
S300.....	17
S500.....	17
S301.....	18
S501.....	18

S310 .....	18
S320 .....	19
S520 .....	19
S330 .....	20
S340 .....	20
S530 .....	20
S540 .....	21
T051 .....	21
T061 .....	21
<b>Speed, load and current curves .....</b>	<b>22</b>
Load in push: 4,000 N, 5,000 N, 6,000 N, built-in dimension: S/2+120 (3-stage).....	22
Load in push: 4,000 N, 5,000 N, 6,000 N, built-in dimension: S/2+240 (3-stage).....	22
Load in push: 4,000 N, 5,000 N, 6,000 N, built-in dimension: S+180 (2-stage).....	23
Load in push: 4,000 N, 5,000 N, 6,000 N, built-in dimension: S+250 (2-stage).....	23
Load in push: 4,000 N, 5,000 N, 6,000 N – LC3 with stable power supply, type G-motor.....	24
Load in push: 4,000 N, 5,000 N, 6,000 N – LC3 in a system with CO71 .....	24
Load in push: 4,000 N, 5,000 N, 6,000 N - LC3 with stable power supply, type B motor .....	25
<b>Contacts .....</b>	<b>26</b>

## Introduction

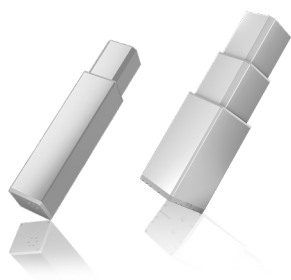

The LC3 2-stage and 3-stage set the standard for vertical lifting columns to high-end medical applications. This compact lifting column fulfils the market requirements for a solid and stable lifting column.

High speed and advanced memory options ensure fast and easy positioning of the application. The smooth design with cables through the column make it very cleaning friendly. The LC3 moves very quietly even with substantial loads.

## Features and options

Load in push	4,000 N, 5,000 N, 6,000 N
Load in pull	4,000 N
Profile colour	Anodised aluminium
Top and bottom plate colour	Zink grey
Protection class	IPX4 standard, IPX6 optional
Motor	24 V DC Type G to be used with LINAK control box Type B to be used with customer supplied control box
Stroke length	3-stage: 400-700 mm in steps of 50 mm, 200-700 mm in steps of 1 mm on request. 2-stage: 200-700 mm in steps of 50 mm, 200-700 mm in steps of 1 mm on request.
Built-in dimensions	See built-in dimension matrix 3-stage: $S/2 + 120$ mm, min. BID 320 or $S/2 + 240$ mm, min. BID 440 2-stage: $S+180$ mm, min. BID 320 or $S+250$ mm, min. BID 390
Positioning options	Dual Hall, Potentiometer
Noise level	50 dB (A)
Weight	16.4 kg - BID 320, 3-stage
Safety nut	Standard
Built-in end stop switch	Signal switch for LINAK CO control boxes. Power switch with G motor for CBJC - special item only. Power switch for customer supplied control box.
Safety factor	LC3 Push – see SF curve, Pull SF5
Dynamic bending moment	3-stage: Up to 1,400 Nm 2-stage: Up to 2,100 Nm
Static bending moment	3-stage: Up to 3,000 Nm 2-stage: Up to 3,000 Nm
Protective grounding cable	Optional
Cables through the column	Mains, hand control, motor cable
Mounting directions	Large profile down or large profile up
Connection of motor cable	Fixed or detachable
Mounting of accessory	Mounting holes for bracket on request

## Usage

Duty cycle	10%, 2 minutes continuous use followed by 18 minutes not in use
Operation temperature	+5 °C to + 40 °C
Storage temperature	-40 °C to + 70 °C
Compatibility	Compatible with LINAK control boxes. Please contact LINAK.
Relative humidity	20% to 80% – non-condensing
Atmospheric pressure	700 to 1060 hPa
Meters above sea level	Max. 3000 meters
Approvals	IEC 60601-1 IEC 60601-1-6 ANSI/AAMI ES60601-1 CAN/CSA-C22.2 No. 60601-1



## 3-stage installation dimensions

### Standard profile vs stroke length

	Stroke length: 400-700 mm*						
BID at stroke	400	450	500	550	600	650	700
S/2 + 120 mm Standard	320	345	370	395	420	445	470
S/2 + 240 mm Heavy duty	440	465	490	515	540	565	590

\* Stroke length tolerance: +3 / -7 mm

### Special dimensions

	Stroke length 200-400 mm	Stroke length 401-700 mm
	Built-in dimensions	
S/2 + 120 mm	Min. 320	S/2+120
S/2 + 240 mm	Min. 440	S/2+240

Example special dimensions: S=558 mm, BID = 399, S/2 + 120 mm

Minimum built-in dimension is 320 mm due to the motor housing and the design of the lifting column.

### Static bending moment (Nm)

	Push force (N)		
	4,000	5,000	6,000
S/2 + 120 mm Standard	1,000 Nm	1,000 Nm	1,000 Nm
S/2 + 240 mm Heavy duty	3,000 Nm	3,000 Nm	3,000 Nm



## 2-stage installation dimensions

### Standard profile vs stroke length

	Stroke length: 200-700 mm*											
	200	250	300	350	400	450	500	550	600	650	700	
BID at stroke												
S + 180 mm Standard	380	430	480	530	580	630	680	730	780	830	880	
S + 250 mm Heavy duty	450	500	550	600	650	700	750	800	850	900	950	

\* Stroke length tolerance: +3 / -7 mm

### Special dimensions

	Stroke length 140-700 mm	
	Built-in dimensions	
S + 180 mm	Min. 320	S+180
S + 250 mm	Min. 390	S+250

Example special dimensions: S=558 mm, BID = 738, S + 180 mm

Minimum built-in dimension is 320 mm due to the motor housing and the design of the lifting column.

### Static bending moment (Nm)

	Push force (N)		
	4,000	5,000	6,000
S + 180 mm Standard	2,000 Nm	2,000 Nm	2,000 Nm
S + 250 mm Heavy duty	3,000 Nm	3,000 Nm	3,000 Nm



## LC3 safety factor in push and pull

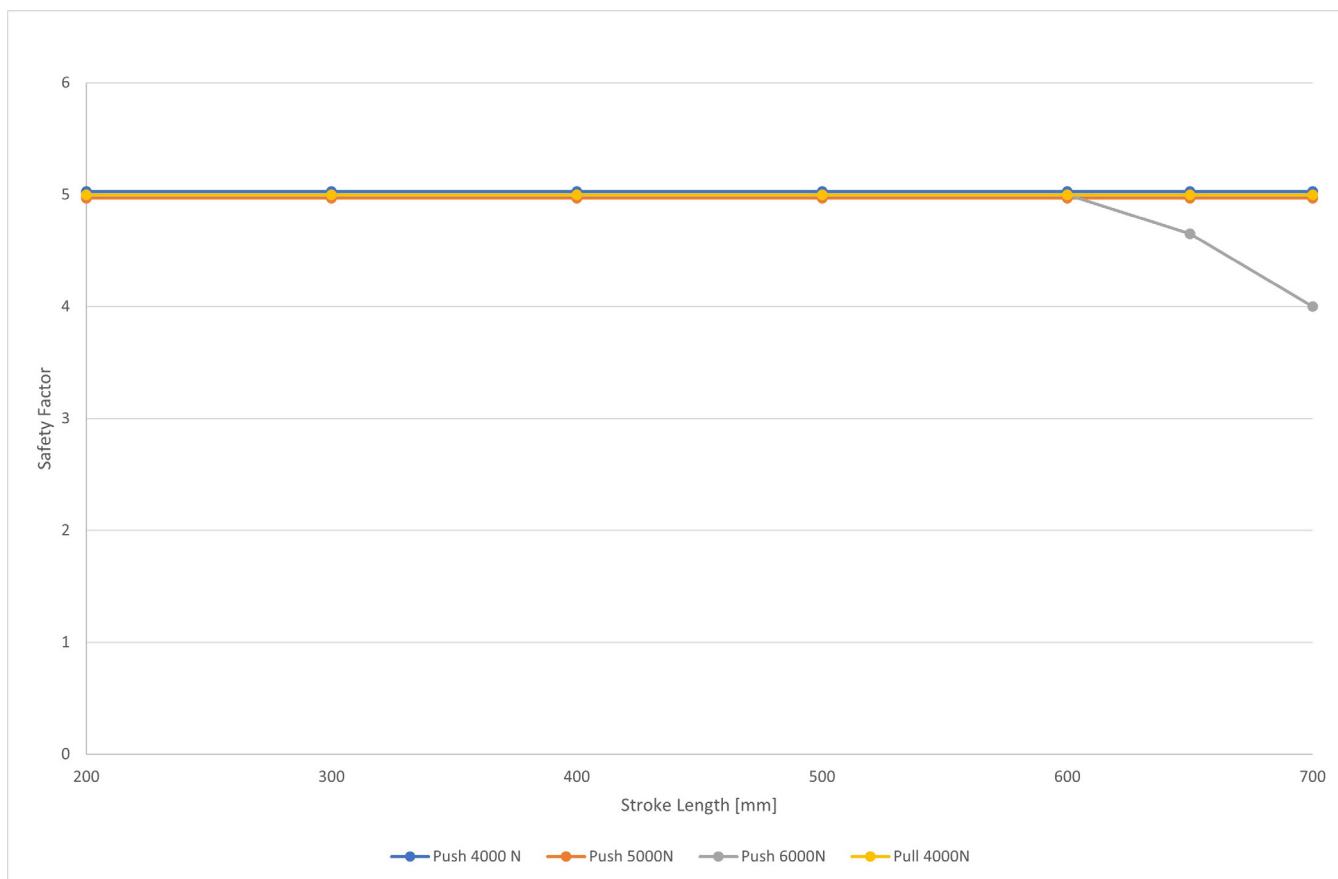

# Ordering example

<b>Lifting Column type:</b>	LC 3	
<b>Spindel pitch:</b>	100	060 : 6 mm (6000 N)      080 = 8 mm (5000 N)      100 = 10 mm (4000 N)
<b>Stroke length:</b>	400	000 : mm      Min. 200 - Max.700 mm in steps of 50 mm
<b>Option</b>	T000 ABCD	Count Max. : 2
	<p><b>A =</b>    T= Top entry motor supply           S= Side entry motor supply</p> <p><b>B =</b>    0 = None           1 = Minifit through           2 = HB Through           3 = Side entry motor supply, Cable length 500 mm           5 = Side entry motor supply, Cable length 80 mm</p> <p><b>C =</b>    0 = None           1 = Minifit through, available with 400 mm, 500 mm and 700 mm stroke length only           2 = HB Through, on request           3 = Mains through 1-2 pin on request           4 = Mains through 2-2 pin on request           5 = Mains through 1-3 pin: always with earth profile D=1 on request           6 = Mains through 2-3 pin: always with earth profile D=1 on request</p> <p><b>D =</b>    0 = No Earth profile           1 = Earth profile</p>	<p>0 1 0 1 1 0 0 0 1 1 1 1 1 1 0 1</p> <p>Please notice that max. sum of options is 2*</p>
<b>Feedback:</b>	0M	<p>00 : None (also to be used when encoded wo feedback 0 or 1)</p> <p>0H : Dual Hall digital (only possible with power switch 0)</p> <p>0M : Dual Hall, encoded (only possible with encoded switch 1)</p> <p>0P : Potentiometer (only possible with power switch 0) on request</p>
<b>Installation dimension:</b>	0320	0000 =
<b>Part</b>	0	<p>0 = 3 part column 1/2s + 120 min. BID 320</p> <p>1 = 3 part column 1/2s+240 min. BID 440, heavy duty</p> <p>2 = 2 part column S+180 min. BID = 320 mm</p> <p>5 = 2 part column S+250 (heavy duty min. BID 390)</p>
<b>Motor type:</b>	G	<p>B = 24 VDC to be used if customer supplied control box</p> <p>G = 24VDC to be used if LINAK control</p>
<b>Endstop:</b>	1	<p>0 : Power switch</p> <p>1 = Encoded signal swtch (ONLY "G" MOTOR)</p>
<b>Mounting direction:</b>	1	<p>1 : Top plate up 3-stage (not valid option for mains through)</p> <p>2 : Top plate down 3-stage</p> <p>3 : Top plate up 2-stage (not valid option for mains through)</p> <p>4 : Top plate down 2-stage</p>
<b>IP degree:</b>	4	<p>4 : IPX4 (only valid option for mains through with top plate down)</p> <p>6 : IPX6 (not valid option for mains through)</p>
<b>Colour:</b>	-	- : Aluminium
	0	0
	0	0
	0	0

**LC3100400T0000M03200G114-000**

\* Example: If an LC3 version with mains cable through the column is needed, it is possible to specify one more cable through the column, e.g. earth profile giving a maximum count of 2.



## Dimensions

All dimensions are in mm.

### LC3 3-stage

BID tolerance: +/- 2.5 mm

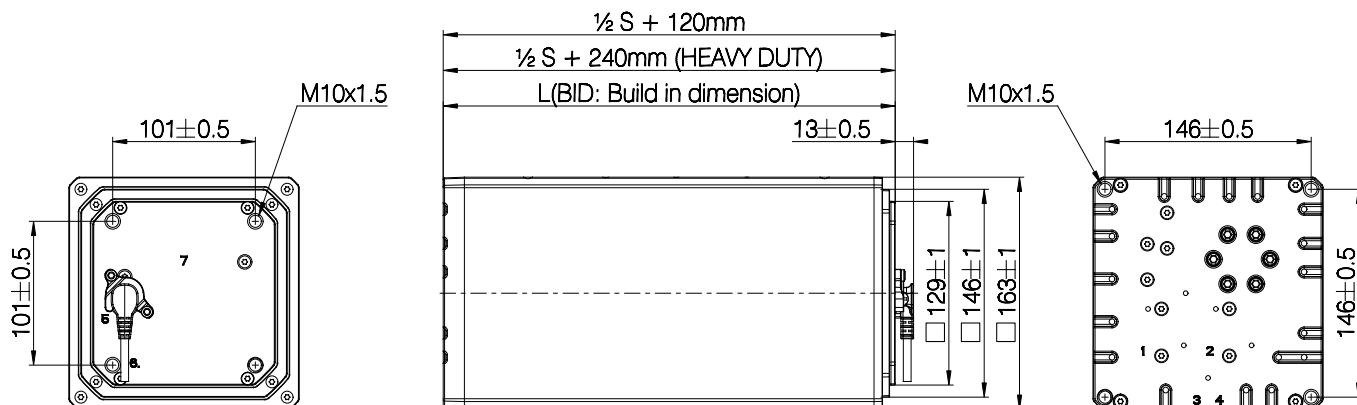

Drawing no: 1002W9005

### LC3 2-stage

BID tolerance: +/- 2.5 mm

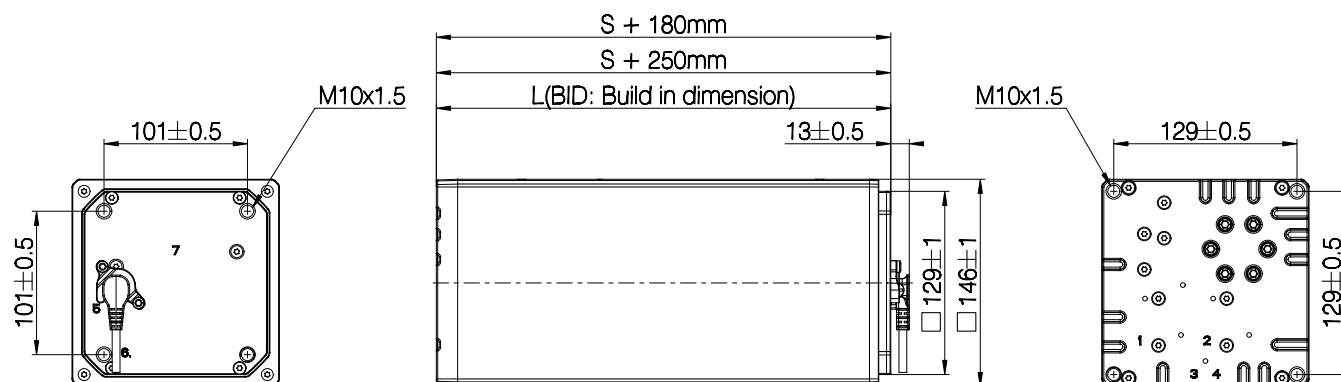

Drawing no: 1002W9008

## LC3 mounting guidelines

It is very simple to mount the LC3 in the application using the 4x M10 mounting holes in both endplates.

If the column is to be used with a high off-center load, we recommend to install the weight in one of the 3 ways illustrated by the green symbols. It is not recommended to install the weight on the opposite side of the mechanical endstop as illustrated with the red symbol. This installation can create an uneven movement when the lifting column reaches the endstop position.

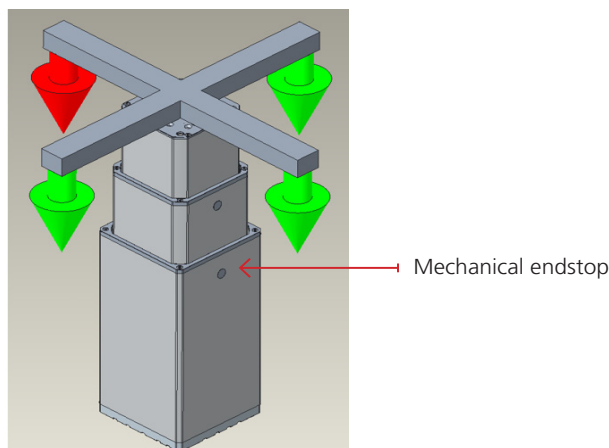

## Cable connections overview

3-stage is used as examples but variants are also applicable for 2-stage.

This overview shows all possible cable connections, but please notice that some variants are upon request.

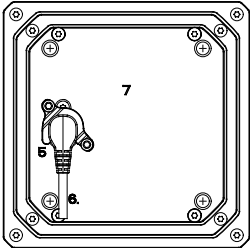
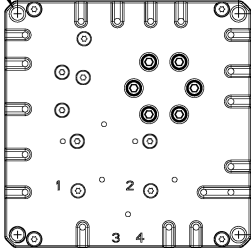
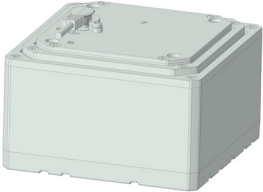
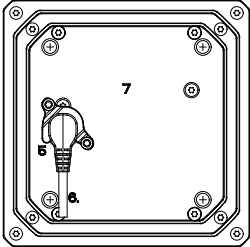
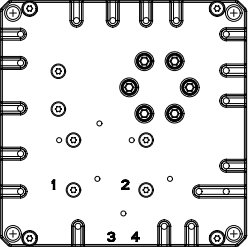
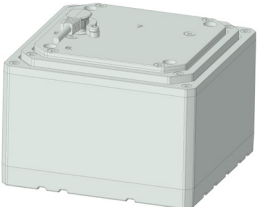
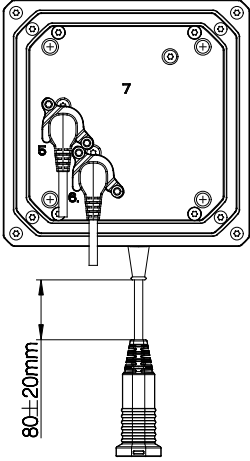
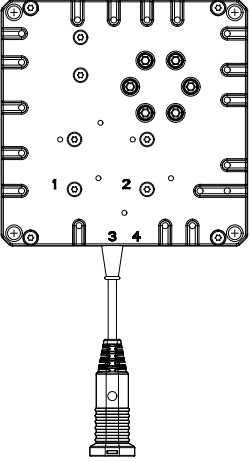
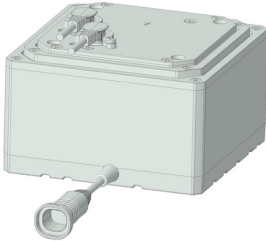
Variant	Top plate Drawing no.:1002W9005		Side entry Drawing no.:1002W9005	Model view
<b>T000</b>				
Connections	5: Motor			
<b>T001</b>				
Connections	5: Motor			Including protective grounding cable
<b>T100</b>				
Connections	5: Motor 6: Minifit through	↔	3: Minifit through	

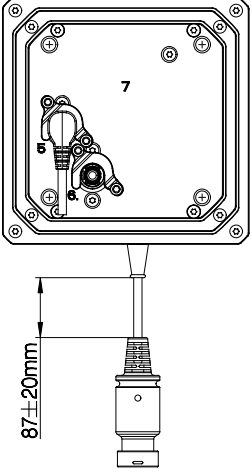
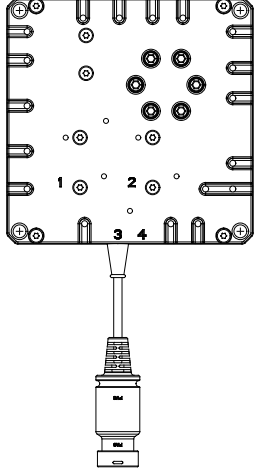
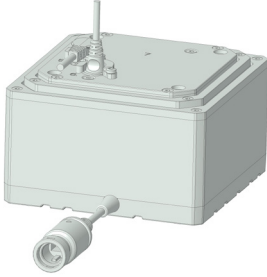
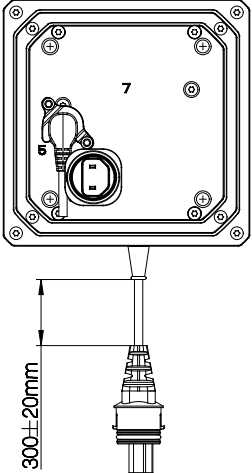
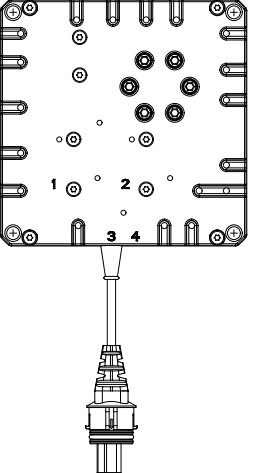
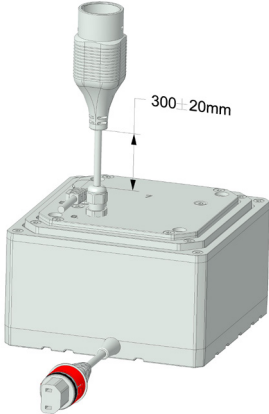
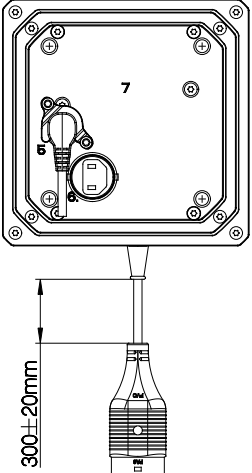
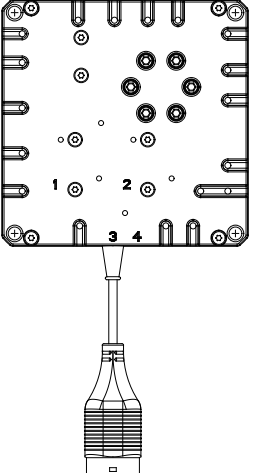
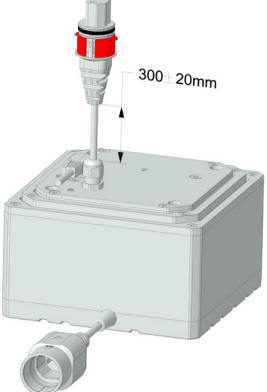
Variant	Top plate Drawing no.:1002W9005	Side entry Drawing no.:1002W9005	Model view
<b>T200</b>			
Connections	5: Motor 6: HB through	↔ 3: HB through	
<b>T030</b>			 <p data-bbox="1118 1263 1422 1357">Note: With mains through option, the top plate will point downwards.</p>
Connections	5: Motor 6: Mains through 1-2 pin	↔ 3: Mains through 1-2 pin	
<b>T040</b>			 <p data-bbox="1118 1883 1422 1977">Note: With mains through option, the top plate will point downwards.</p>
Connections	5: Motor 6: Mains through 2-2 pin	↔ 3: Mains through 2-2 pin	

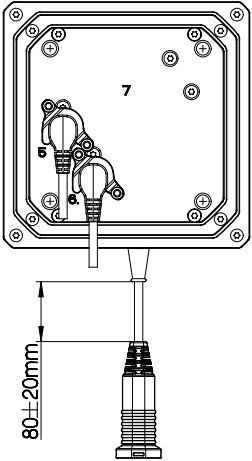
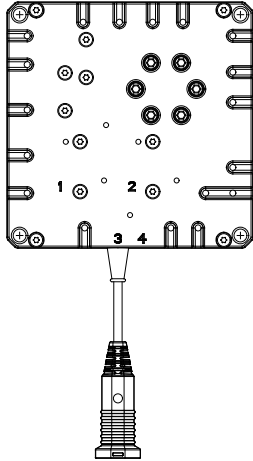
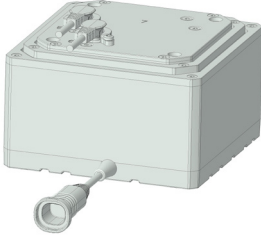
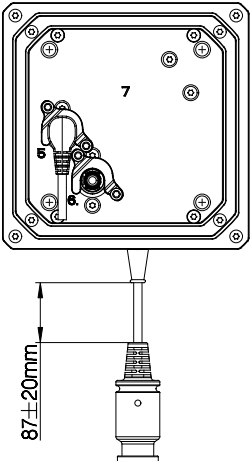
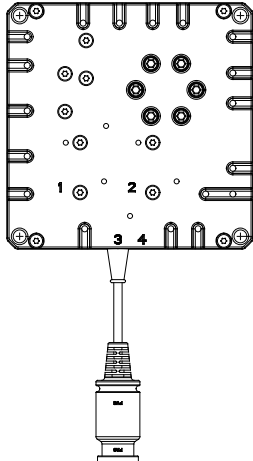
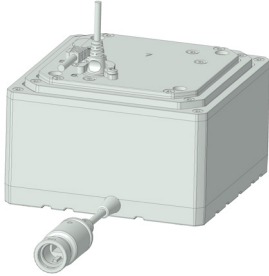
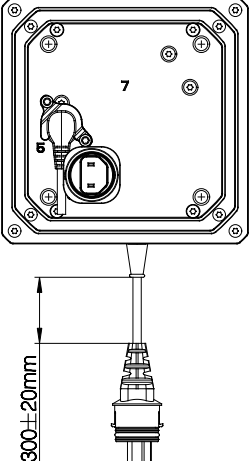
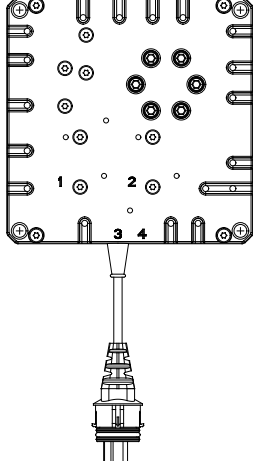
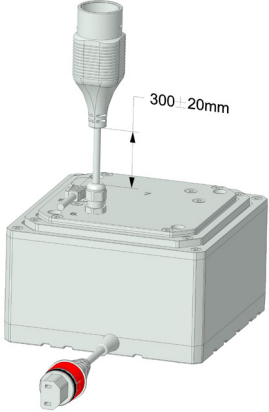
Variant	Top plate Drawing no.:1002W9005	Side entry Drawing no.:1002W9005	Model view
<b>T101</b>			
Connections	5: Motor 6: Minifit through	↔ 3: Minifit through	Including protective grounding cable
<b>T201</b>			
Connections	5: Motor 6: HB through	↔ 3: HB through	Including protective grounding cable
<b>T031</b>			 <p data-bbox="1118 1839 1422 1928">Note: With mains through option, the top plate will point downwards.</p>
Connections	5: Motor 6: Mains through 1-2 pin	↔ 3: Mains through 1-2 pin	Including protective grounding cable

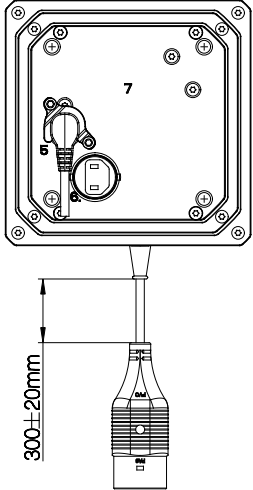
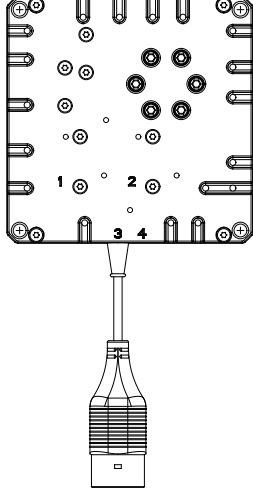
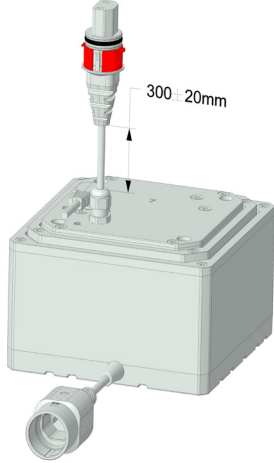
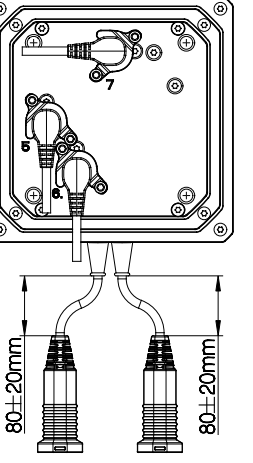
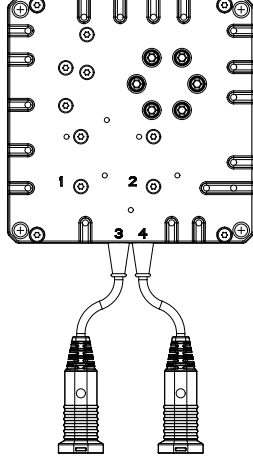
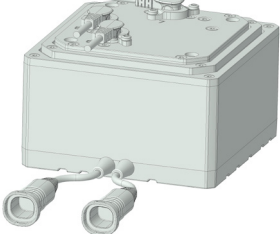
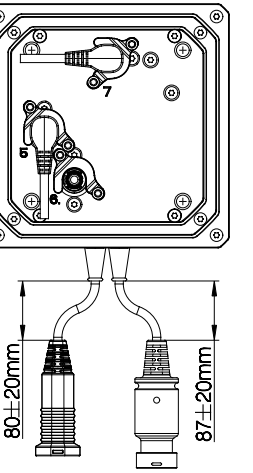
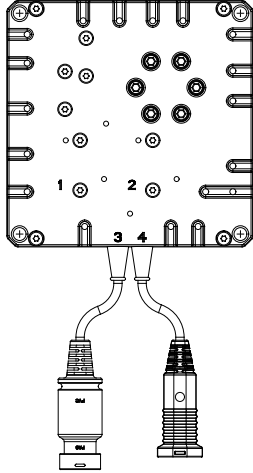
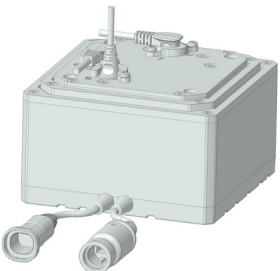
Variant	Top plate Drawing no.:1002W9005	Side entry Drawing no.:1002W9005	Model view
<b>T041</b>			 <p data-bbox="1118 689 1422 786">Note: With mains through option, the top plate will point downwards.</p>
Connections	5: Motor 6: Mains through 2-2 pin	↔ 3: Mains through 2-2 pin	Including protective grounding cable
<b>T110</b>			
Connections	5: Motor 6: Minifit through (top) 7: Minifit through (top)	↔ 3: Minifit through (side) ↔ 4: Minifit through (side)	
<b>T120</b>			
Connections	5: Motor 6: HB through 7: Minifit through	↔ 3: HB through ↔ 4: Minifit through	

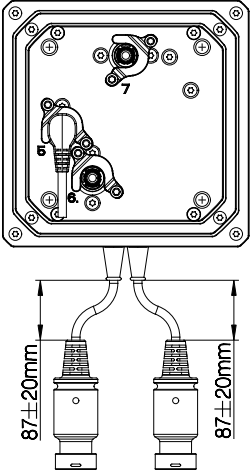
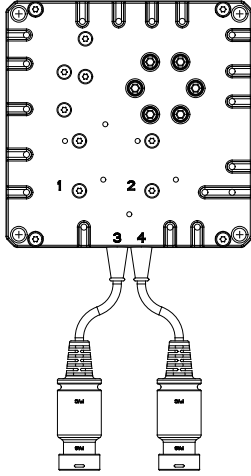
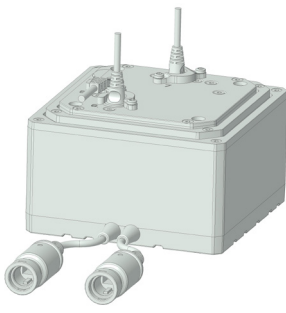
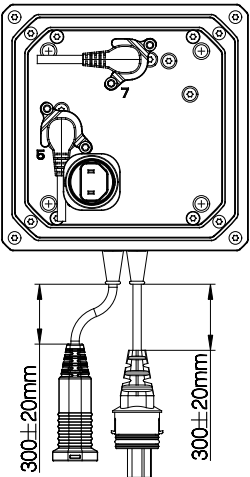
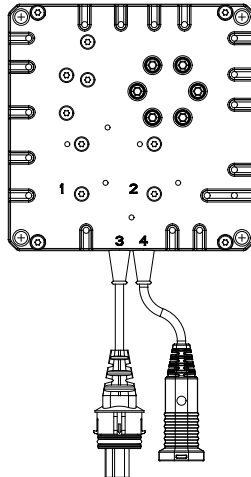
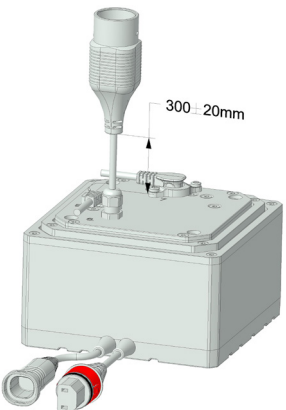
Variant	Top plate Drawing no.:1002W9005	Side entry Drawing no.:1002W9005	Model view
<p><b>T220</b></p>			
<p>Connections</p>	<p>5: Motor 6: HB through (top) 7: HB through (top)</p>	<p>↔ 3: HB through (side) ↔ 4: HB through (side)</p>	
<p><b>T130</b></p>			 <p>Note: With mains through option, the top plate will point downwards.</p>
<p>Connections</p>	<p>5: Motor 6: Mains through 1-2 pin 7: Minifit through</p>	<p>↔ 3: Mains through 1-2 pin ↔ 4: Minifit through</p>	

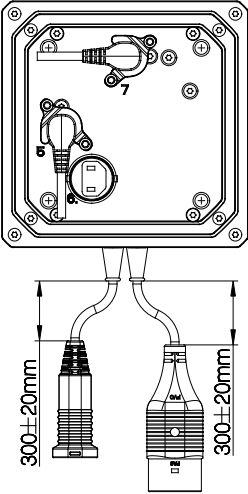
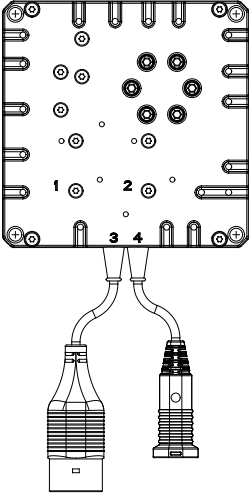
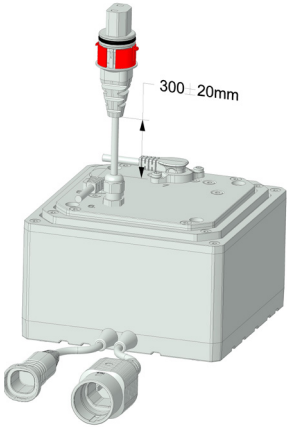
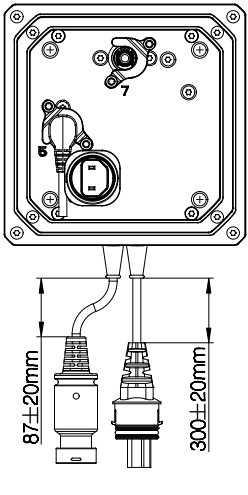
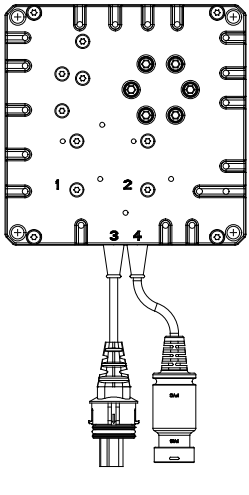
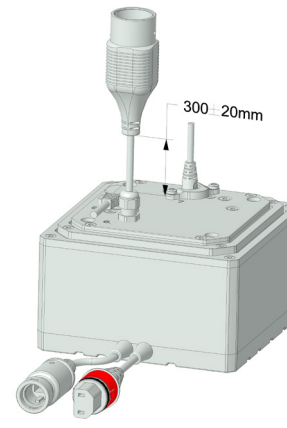
Variant	Top plate Drawing no.:1002W9005	Side entry Drawing no.:1002W9005	Model view
<b>T140</b>			 <p data-bbox="1118 667 1422 757">Note: With mains through option, the top plate will point downwards.</p>
Connections	5: Motor 6: Mains through 2-2 pin 7: Minifit through	↔ 3: Mains through 2-2 pin ↔ 4: Minifit through	
<b>T230</b>			 <p data-bbox="1118 1328 1422 1417">Note: With mains through option, the top plate will point downwards.</p>
Connections	5: Motor 6: Mains through 1-2 pin 7: HB through	↔ 3: Mains through 1-2 pin ↔ 4: HB through	

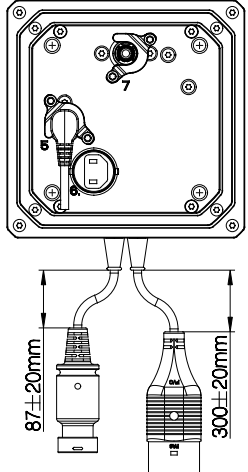
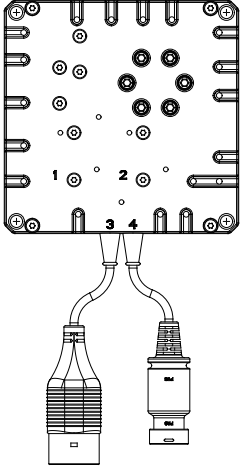
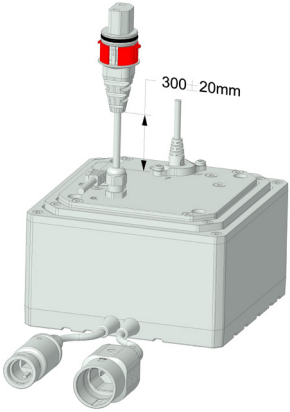
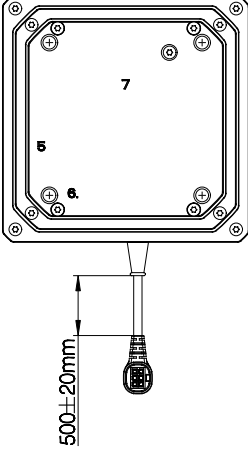
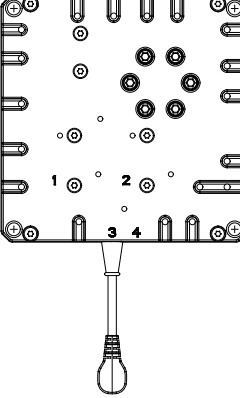
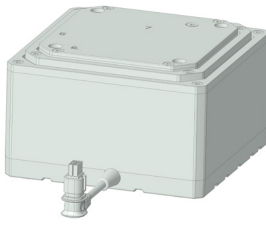
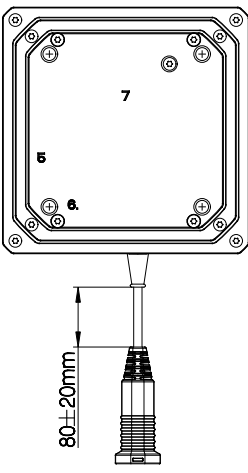
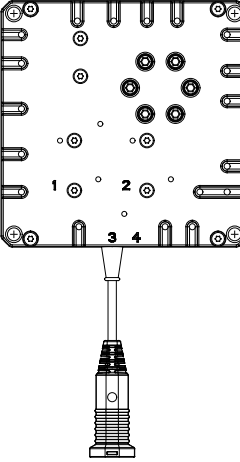
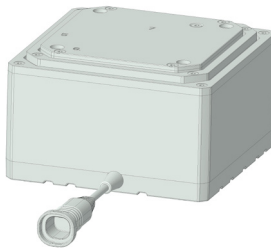
Variant	Top plate Drawing no.:1002W9005	Side entry Drawing no.:1002W9005	Model view
<p><b>T240</b></p>			 <p>Note: With mains through option, the top plate will point downwards.</p>
<p>Connections</p>	<p>5: Motor 6: Mains through 2-2 pin 7: HB through</p>	<p>↔ 3: Mains through 2-2 pin ↔ 4: HB through</p>	
<p><b>S300</b></p>			
<p>Connections</p>		<p>3: Motor supply</p>	
<p><b>S500</b></p>			
<p>Connections</p>		<p>3: Motor supply</p>	

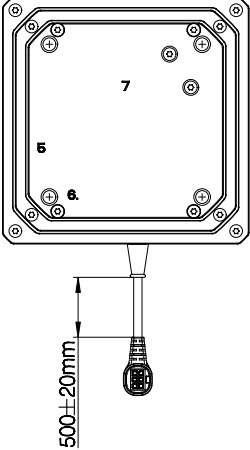
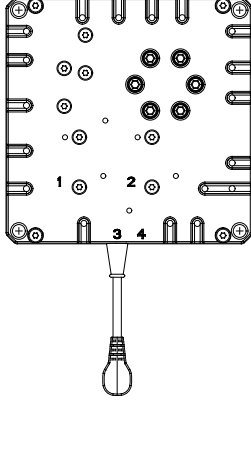
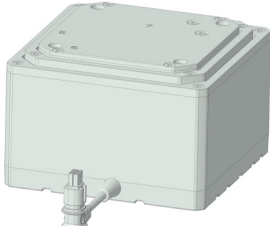
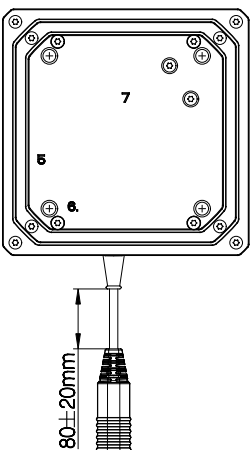
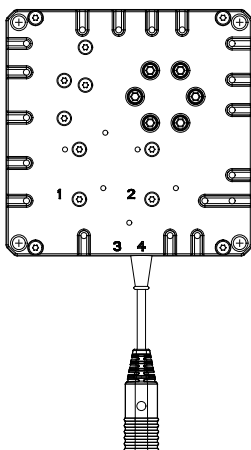
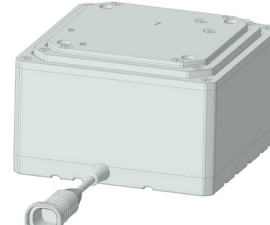
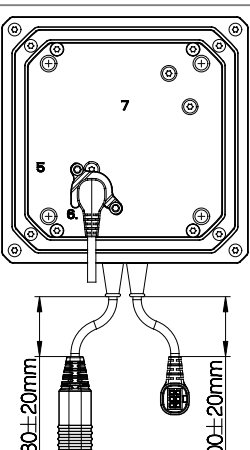
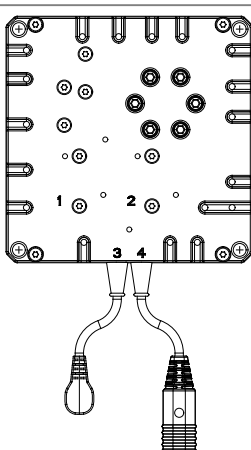
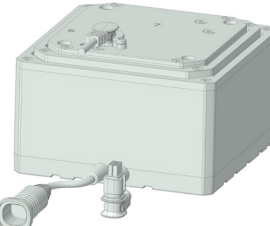
Variant	Top plate Drawing no.:1002W9005	Side entry Drawing no.:1002W9005	Model view
<b>S301</b>			
Connections		3: Motor supply	Including protective grounding cable
<b>S501</b>			
Connections		3: Motor supply	Including protective grounding cable
<b>S310</b>			
Connections	6: Minifit through	3: Motor supply ↔ 4: Minifit through	

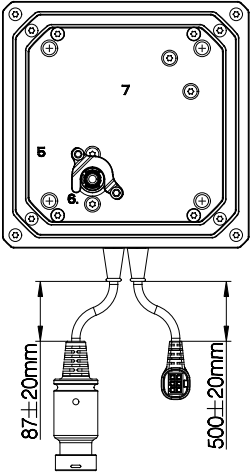
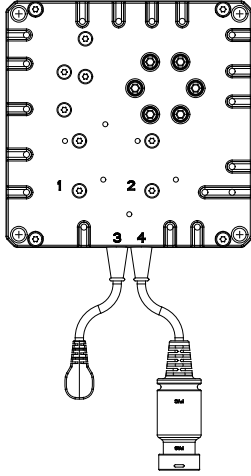
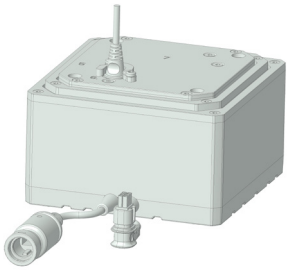
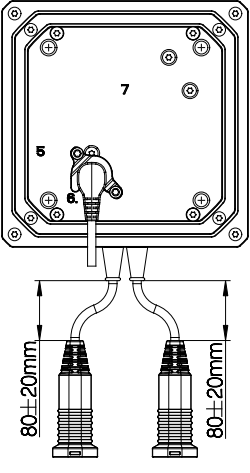
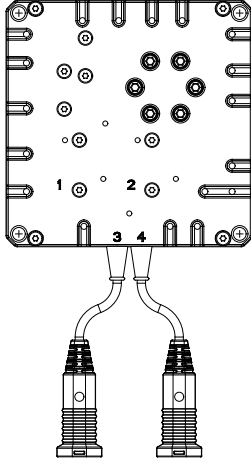
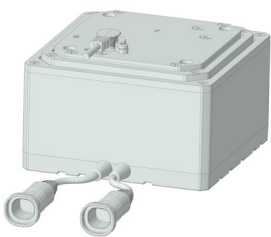
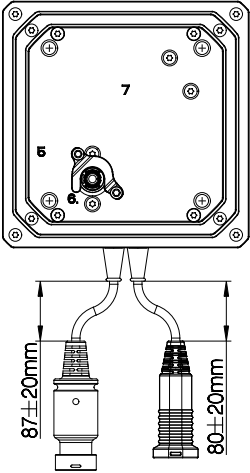
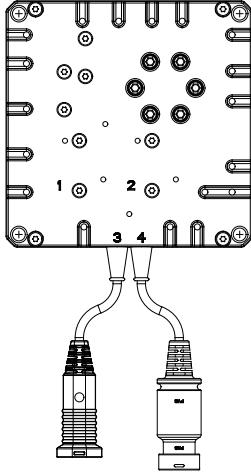
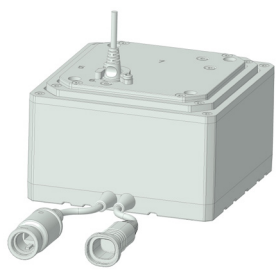
Variant	Top plate Drawing no.:1002W9005	Side entry Drawing no.:1002W9005	Model view
S320			
Connections	6: HB through	↔ 3: Motor supply 4: HB through	
S510			
Connections	6: Minifit through	↔ 3: Motor supply 4: Minifit through	
S520			
Connections	6: HB through	↔ 3: Motor supply 4: HB through	

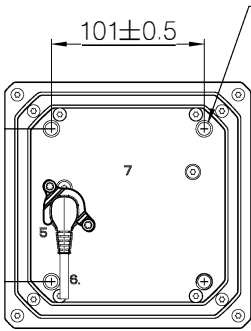
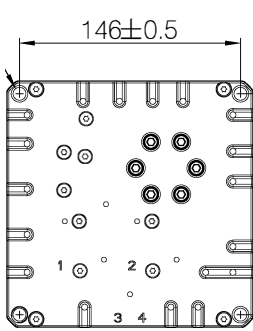
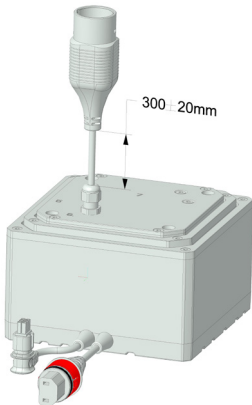
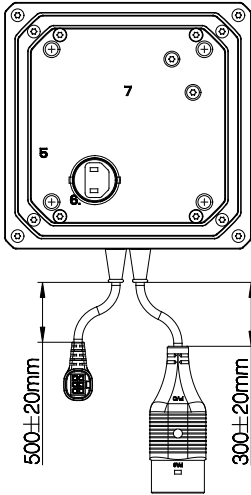
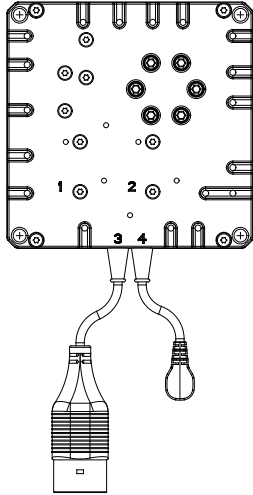
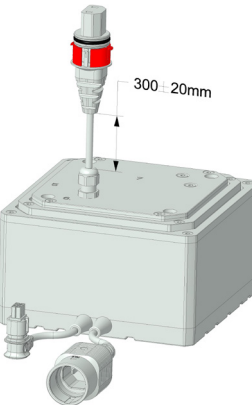
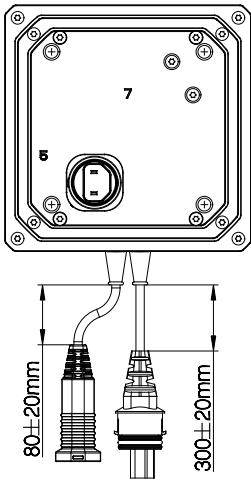
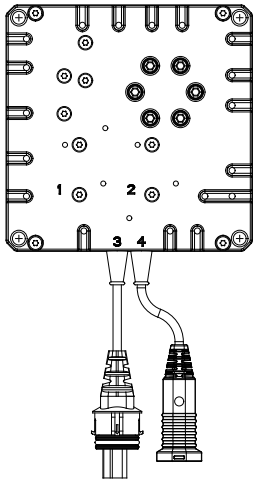
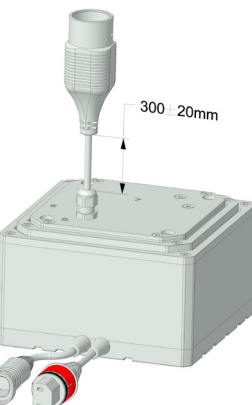
Variant	Top plate Drawing no.:1002W9005	Side entry Drawing no.:1002W9005	Model view
<b>S330</b>			 <p data-bbox="1118 663 1422 757">Note: With mains through option, the top plate will point downwards.</p>
Connections	6: Mains through 1-2 pin	↔ 3: Mains through 1-2 pin 4: Motor	
<b>S340</b>			 <p data-bbox="1118 1279 1422 1373">Note: With mains through option, the top plate will point downwards.</p>
Connections	6: Mains through 2-2 pin	↔ 3: Mains through 2-2 pin 4: Motor	
<b>S530</b>			 <p data-bbox="1118 1895 1422 1989">Note: With mains through option, the top plate will point downwards.</p>
Connections	6: Mains through 1-2 pin	↔ 3: Mains through 1-2 pin 4: Motor	

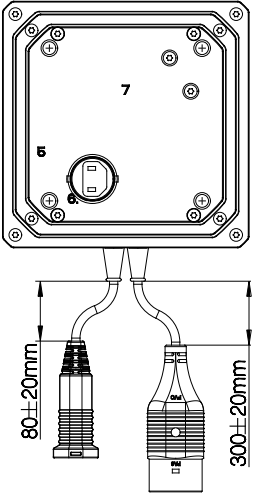
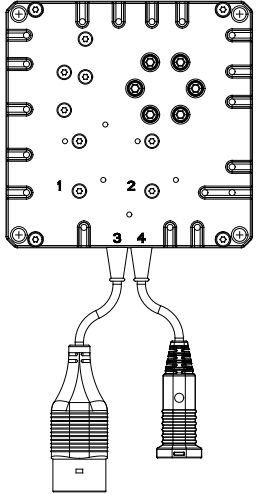
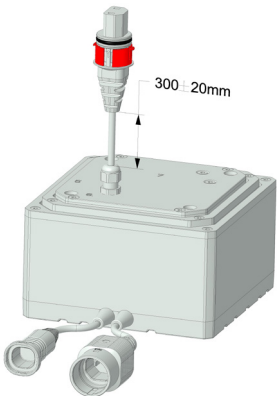
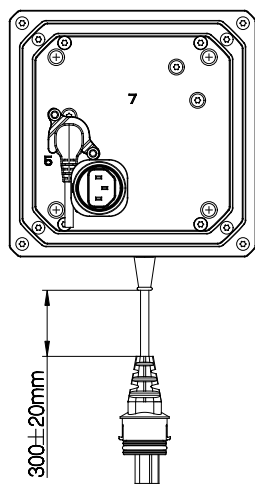
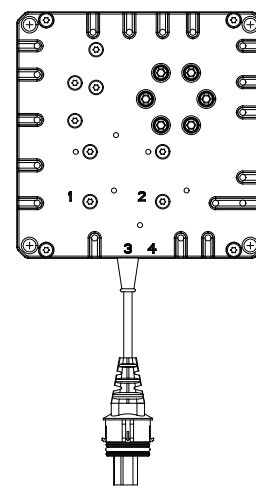
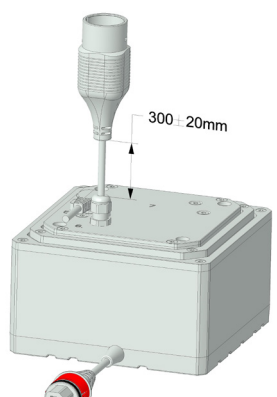
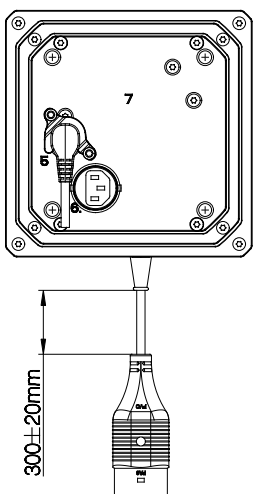
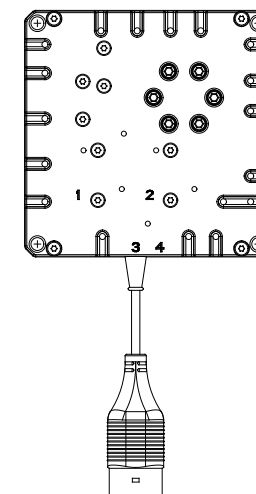
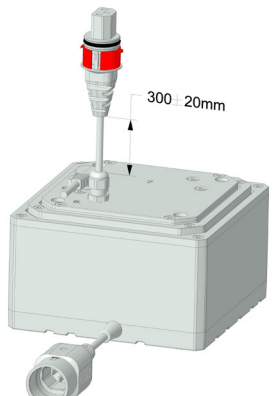
Variant	Top plate Drawing no.:1002W9005	Side entry Drawing no.:1002W9005	Model view
<b>S540</b>			 <p data-bbox="1118 629 1422 719">Note: With mains through option, the top plate will point downwards.</p>
Connections	6: Mains through 2-2 pin	↔ 3: Mains through 2-2 pin 4: Motor	
<b>T051</b>			 <p data-bbox="1118 1249 1422 1339">Note: With mains through option, the top plate will point downwards.</p>
Connections	5: Motor 6: Mains through 1-3 pin with earth	↔ 3: Mains through 1-3 pin	
<b>T061</b>			
Connections	5: Motor 6: Mains through 2-3 pin with earth	↔ 3: Mains through 2-3 pin	

## Speed, load and current curves

Bending load curve including off center load

### Load in push: 4,000 N, 5,000 N, 6,000 N, built-in dimension: S/2+120 (3-stage)

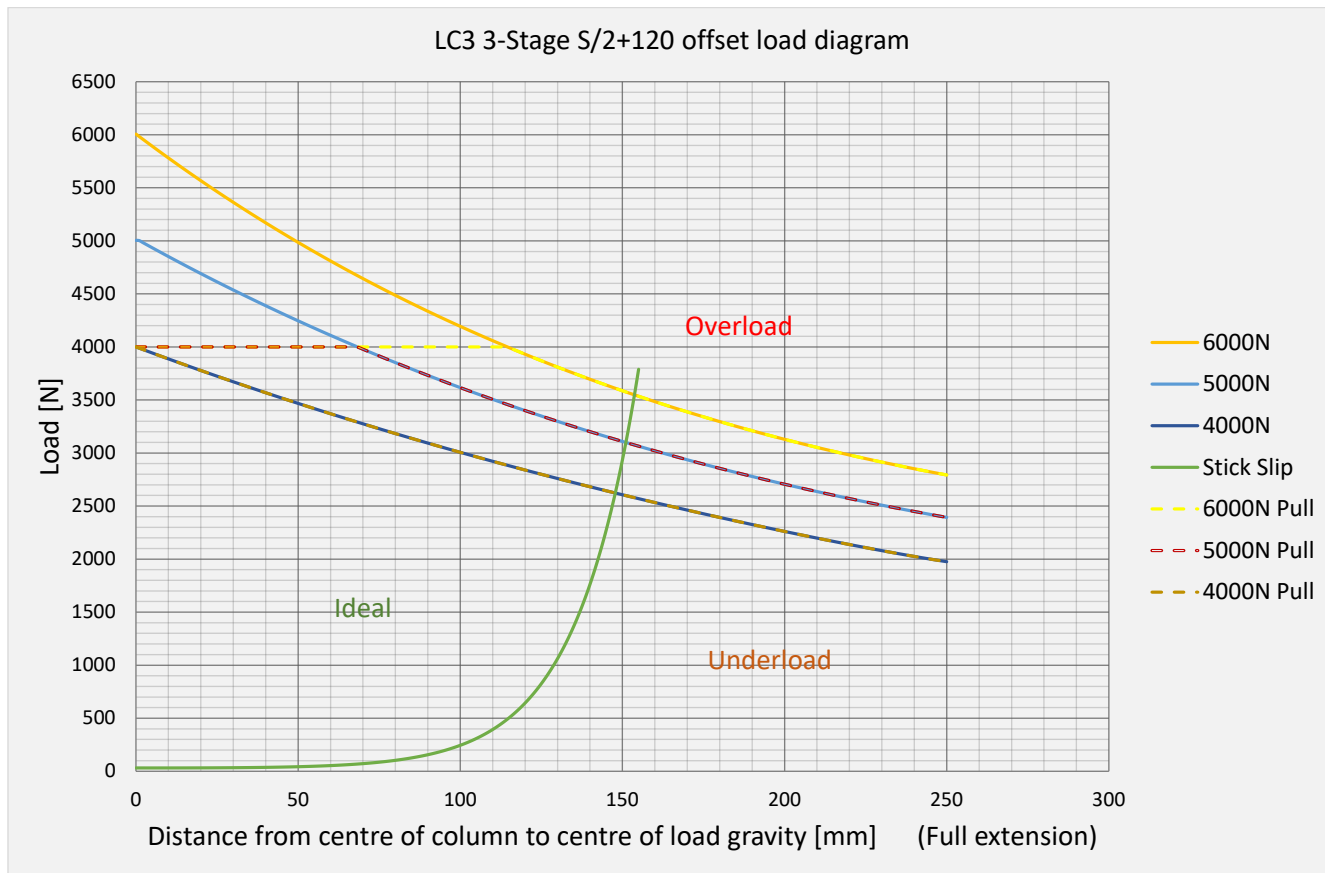

### Load in push: 4,000 N, 5,000 N, 6,000 N, built-in dimension: S/2+240 (3-stage)

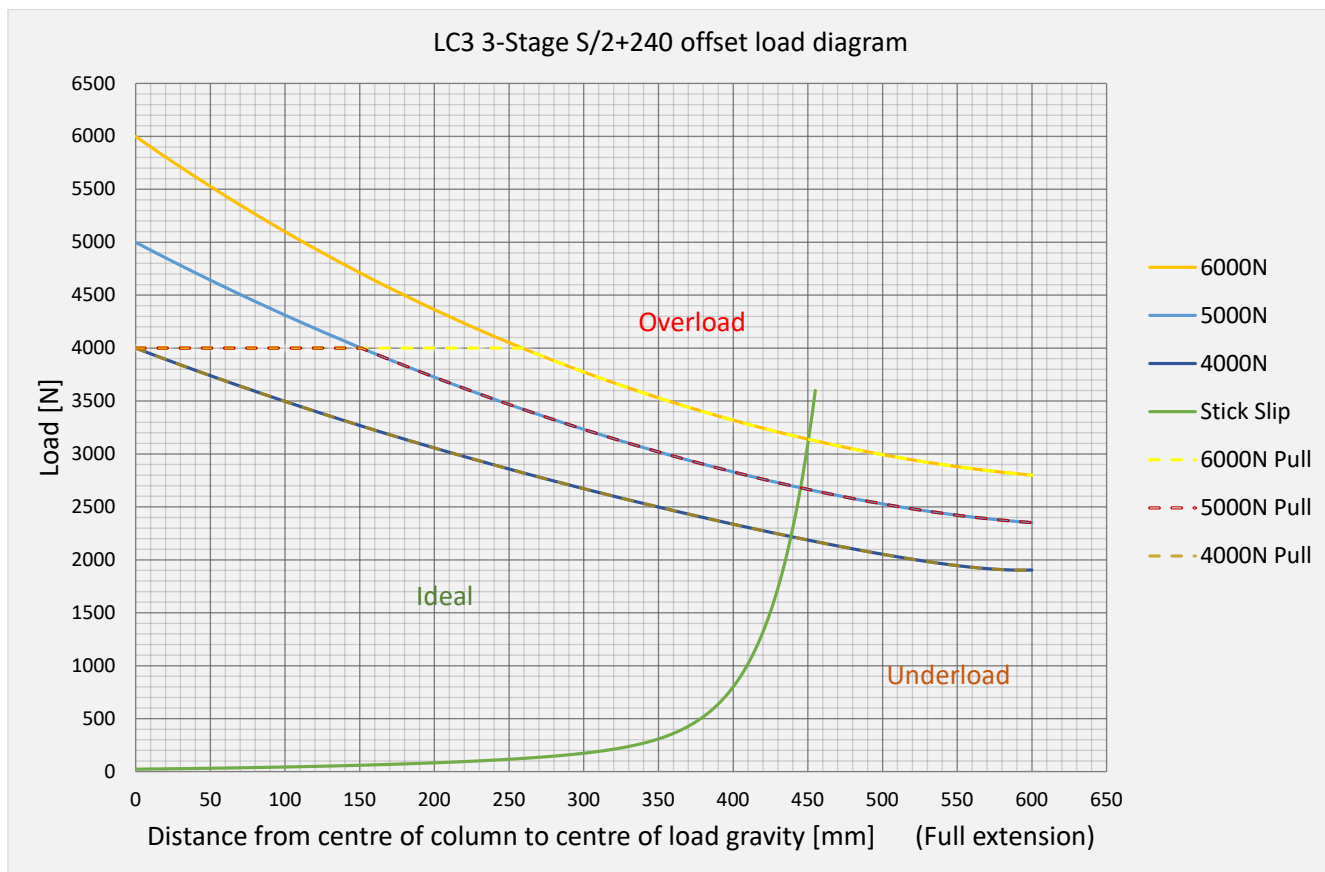

### Load in push: 4,000 N, 5,000 N, 6,000 N, built-in dimension: S+180 (2-stage)

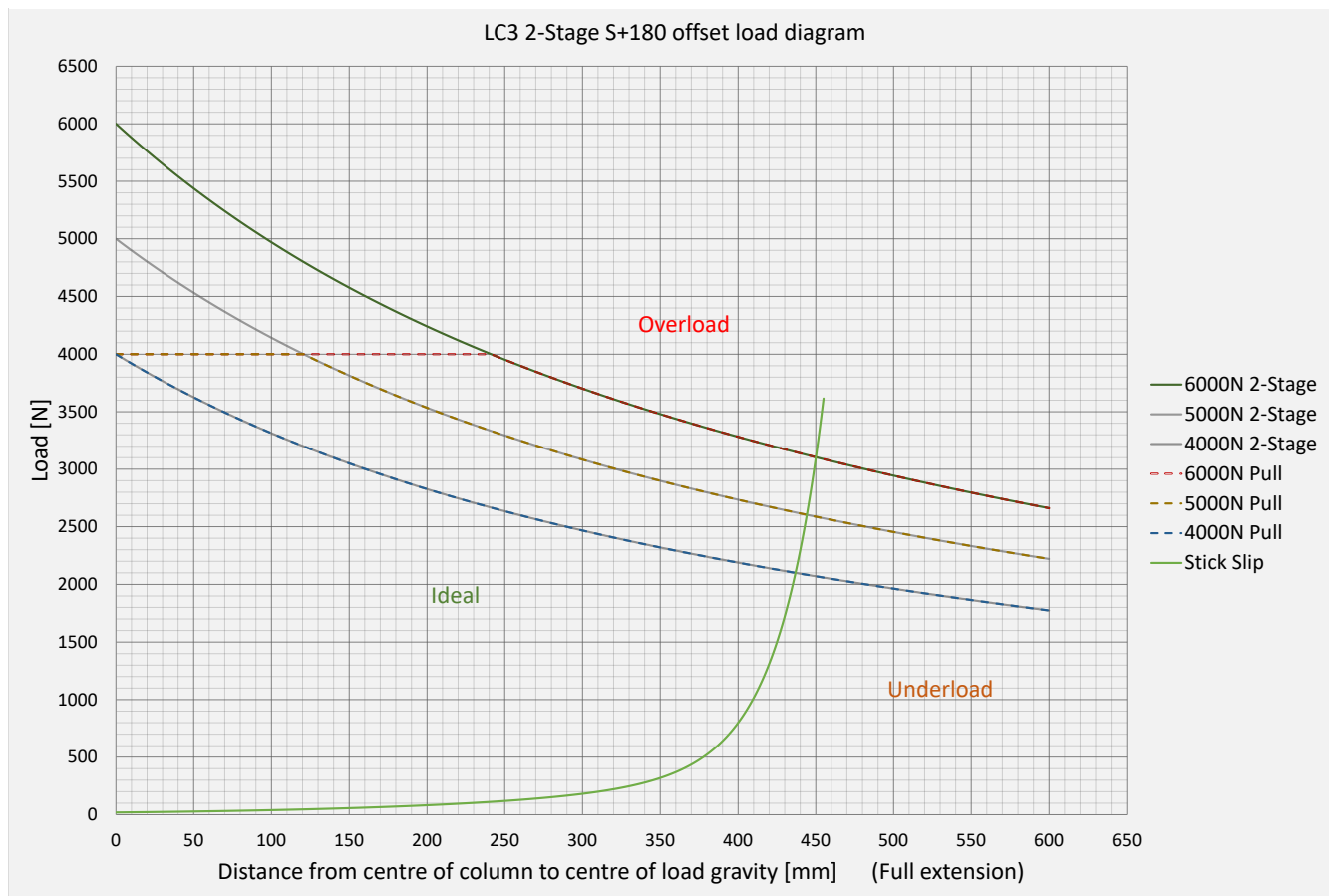

### Load in push: 4,000 N, 5,000 N, 6,000 N, built-in dimension: S+250 (2-stage)

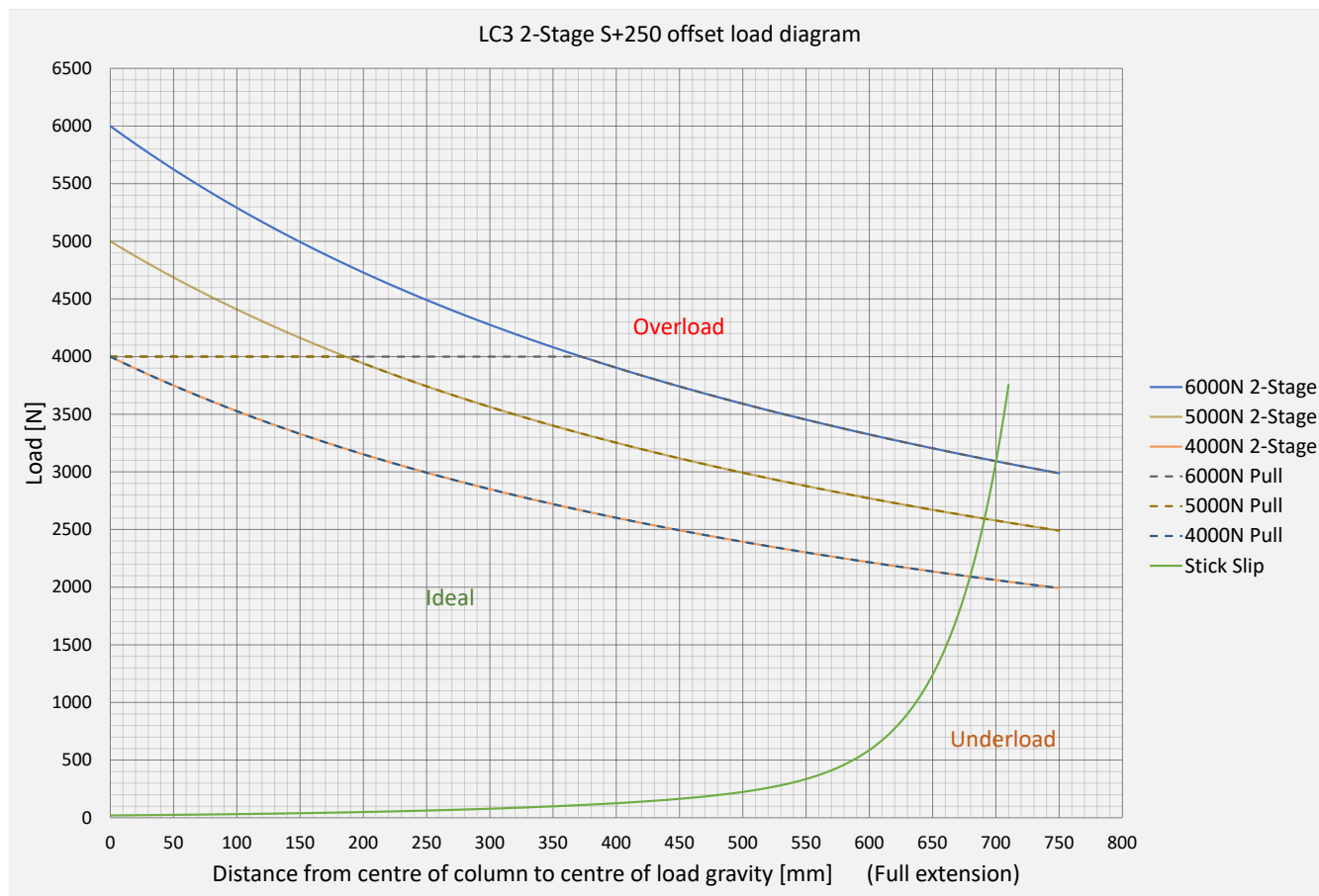

Load in push: 4,000 N, 5,000 N, 6,000 N – LC3 with stable power supply, type G-motor

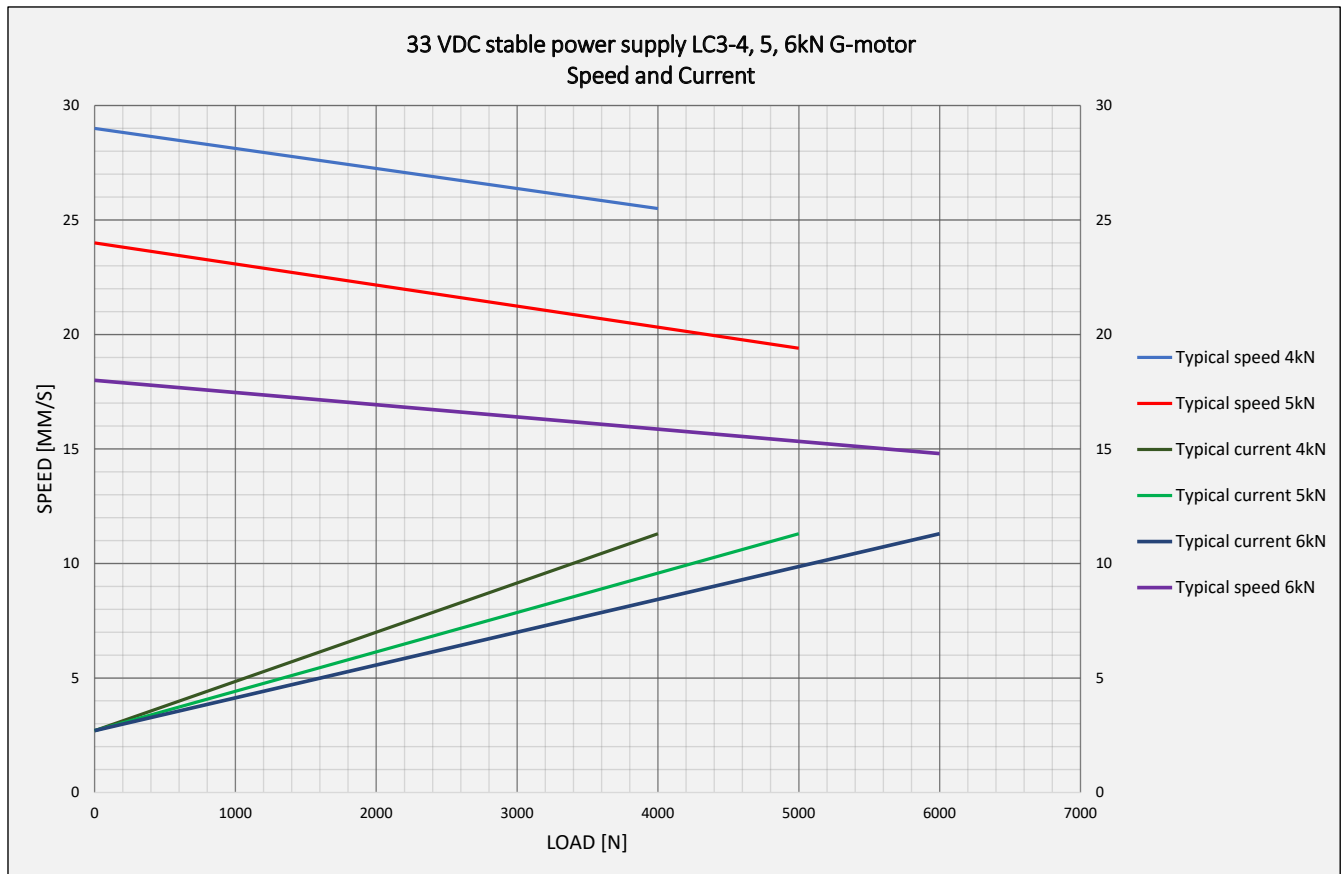

Load in push: 4,000 N, 5,000 N, 6,000 N – LC3 in a system with CO71

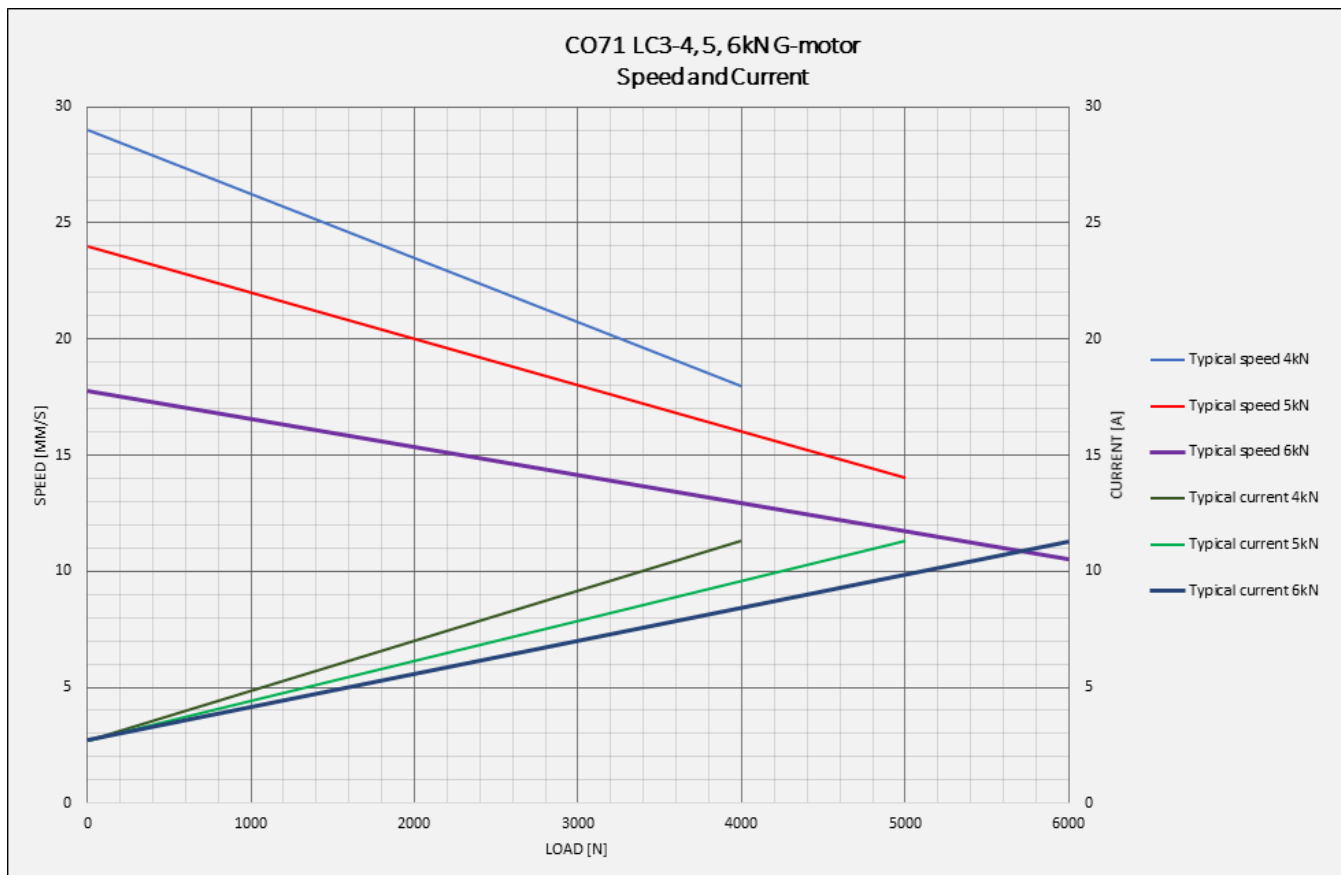

Load in push: 4,000 N, 5,000 N, 6,000 N - LC3 with stable power supply, type B motor

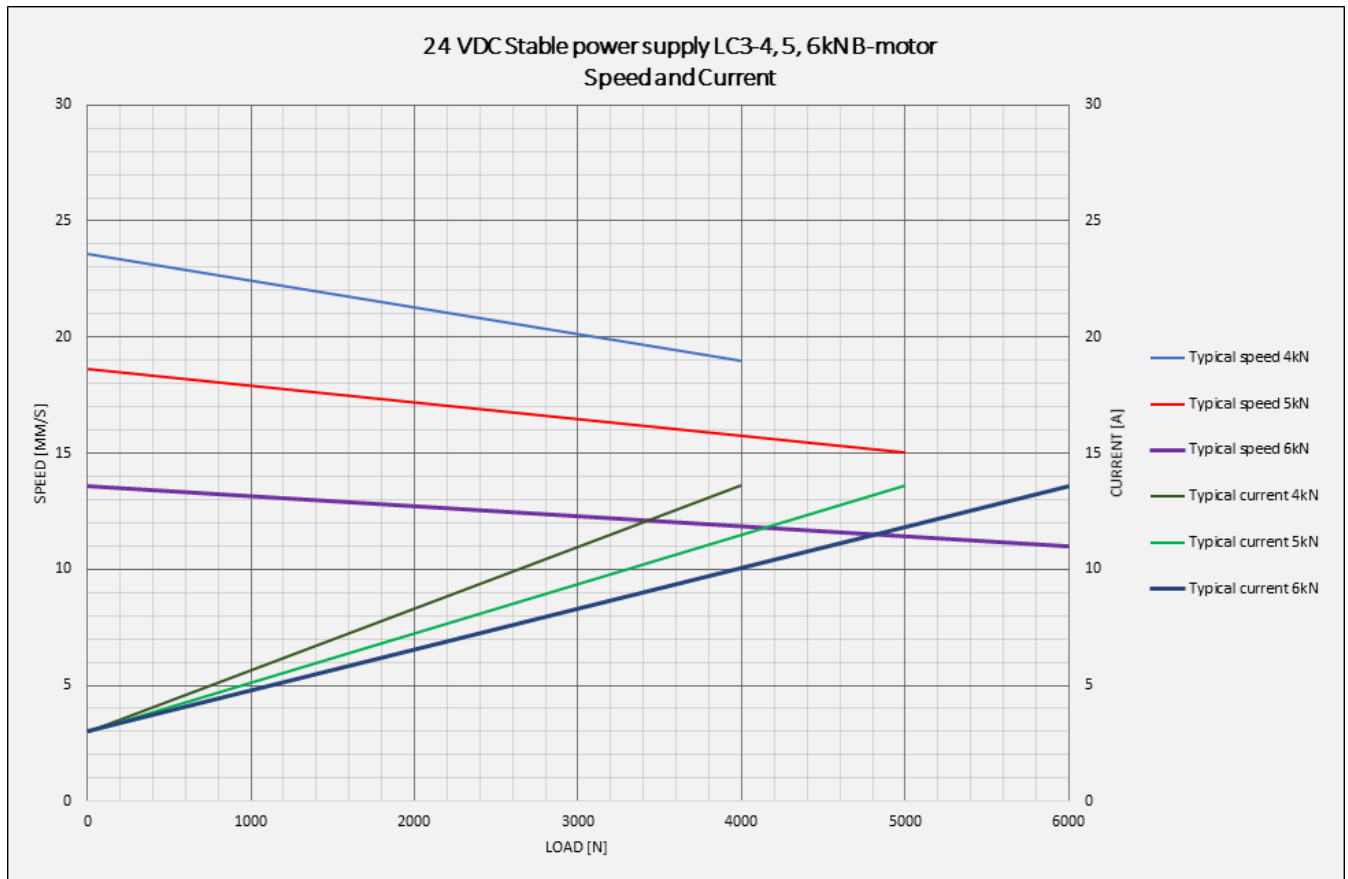

# Contacts

## FACTORIES

Denmark - Headquarters  
LINAK A/S  
Phone: +45 73 15 15 15  
Fax: +45 74 45 80 48  
Fax (Sales): +45 73 15 16 13  
Web: www.linak.com

China  
LINAK (Shenzhen) Actuator Systems, Ltd.  
Phone: +86 755 8610 6656  
Phone: +86 755 8610 6990  
Web: www.linak.cn

Slovakia  
LINAK Slovakia s.r.o.  
Phone: +421 51 7563 444  
Web: www.linak.sk

Thailand  
LINAK APAC Ltd.  
Phone: +66 33 265 400  
Web: www.linak.com

USA  
LINAK U.S. Inc.  
Americas Headquarters  
Phone: +1 502 253 5595  
Fax: +1 502 253 5596  
Web: www.linak-us.com  
www.linak-latinamerica.com

## SUBSIDIARIES

Australia  
LINAK Australia Pty. Ltd  
Phone: +61 3 8796 9777  
Fax: +61 3 8796 9778  
E-mail: sales@linak.com.au  
Web: www.linak.com.au

Austria  
LINAK Zweigniederlassung - Österreich (Wien)  
Phone: +43 (1) 890 7446  
Fax: +43 (1) 890 744615  
E-mail: info@linak.de  
Web: www.linak.at - www.linak.hu

Belgium  
LINAK Actuator-Systems NV/SA  
(Belgium & Luxembourg)  
Phone: +32 (0)9 230 01 09  
E-mail: beinfo@linak.be  
Web: www.linak.be - www.fr.linak.be

Brazil  
LINAK Do Brasil Comércio De Atuadores Ltda.  
Phone: +55 (11) 2832 7070  
Fax: +55 (11) 2832 7060  
E-mail: info@linak.com.br  
Web: www.linak.com.br

Canada  
LINAK Canada Inc.  
Phone: +1 502 253 5595  
Fax: +1 416 255 7720  
E-mail: info@linak.ca  
Web: www.linak-us.com

Czech Republic  
LINAK C&S s.r.o.  
Phone: +42 058 174 1814  
Fax: +42 058 170 2452  
E-mail: info@linak.cz  
Web: www.linak.cz - www.linak.sk

Denmark - International  
LINAK International  
Phone: +45 73 15 15 15  
E-mail: info@linak.com  
Web: www.linak.com

Denmark - Sales  
LINAK Danmark A/S  
Phone: +45 86 80 36 11  
Fax: +45 86 82 90 51  
E-mail: linak@linak-silkeborg.dk  
Web: www.linak.dk

Finland  
LINAK OY  
Phone: +358 10 841 8700  
E-mail: linak@linak.fi  
Web: www.linak.fi

France  
LINAK France E.U.R.L.  
Phone: +33 (0) 2 41 36 34 34  
Fax: +33 (0) 2 41 36 35 00  
E-mail: linak@linak.fr  
Web: www.linak.fr

Germany  
LINAK GmbH  
Phone: +49 6043 9655 0  
Fax: +49 6043 9655 60  
E-mail: info@linak.de  
Web: www.linak.de

India  
LINAK A/S India Liaison Office  
Phone: +91 120 4531797  
Fax: +91 120 4786428  
E-mail: info@linak.in  
Web: www.linak.in

Ireland  
LINAK UK Limited (Ireland)  
Phone: +44 (0)121 544 2211  
Fax: +44 (0)121 544 2552  
+44 (0)796 855 1606 (UK Mobile)  
+35 387 634 6554 (Rep.of Ireland Mobile)  
E-mail: sales@linak.co.uk  
Web: www.linak.co.uk

Italy  
LINAK ITALIA S.r.l.  
Phone: +39 02 48 46 33 66  
Fax: +39 02 48 46 82 52  
E-mail: info@linak.it  
Web: www.linak.it

Japan  
LINAK K.K.  
Phone: 81-45-533-0802  
Fax: 81-45-533-0803  
E-mail: linak@linak.jp  
Web: www.linak.jp

Malaysia  
LINAK Actuators Sdn. Bhd.  
Phone: +60 4 210 6500  
Fax: +60 4 226 8901  
E-mail: info@linak-asia.com  
Web: www.linak.my

Netherlands  
LINAK Actuator-Systems B.V.  
Phone: +31 76 5 42 44 40 /  
+31 76 200 11 10  
E-mail: info@linak.nl  
Web: www.linak.nl

New Zealand  
LINAK New Zealand Ltd  
Phone: +64 9580 2071  
Fax: +64 9580 2072  
E-mail: nzsales@linak.com.au  
Web: www.linak.com.au

Norway  
LINAK Norge AS  
Phone: +47 32 82 90 90  
E-mail: info@linak.no  
Web: www.linak.no

Poland  
LINAK Polska  
LINAK Danmark A/S (Spółka Akcyjna)  
Phone: +48 22 295 09 70 /  
+48 22 295 09 71  
E-mail: info@linak.pl  
Web: www.linak.pl

Republic of Korea  
LINAK Korea Ltd.  
Phone: +82 2 6231 1515  
Fax: +82 2 6231 1516  
E-mail: info@linak.kr  
Web: www.linak.kr

Slovakia  
LINAK Slovakia S.R.O.  
Phone: +421 51 7563 444  
Web: www.linak.sk

Spain  
LINAK Actuadores, S.L.u  
Phone: +34 93 588 27 77  
Fax: +34 93 588 27 85  
E-mail: esma@linak.es  
Web: www.linak.es

Sweden  
LINAK Scandinavia AB  
Phone: +46 8 732 20 00  
Fax: +46 8 732 20 50  
E-mail: info@linak.se  
Web: www.linak.se

Switzerland  
LINAK AG  
Phone: +41 43 388 31 88  
Fax: +41 43 388 31 87  
E-mail: info@linak.ch  
Web: www.linak.ch - www.fr.linak.ch  
www.it.linak.ch

Taiwan  
LINAK (Shenzhen) Actuator systems Ltd.  
Taiwan Representative office  
Phone: +886 2 272 90068  
Fax: +886 2 272 90096  
E-mail: sales@linak.com.tw  
Web: www.linak.com.tw

Turkey  
LINAK İhr. San. ve Tic. A.Ş.  
Phone: +90 312 4726338  
Fax: +90 312 4726635  
E-mail: info@linak.com.tr  
Web: www.linak.com.tr

United Kingdom  
LINAK UK Limited  
Phone: +44 (0)121 544 2211  
Fax: +44 (0)121 544 2552  
E-mail: sales@linak.co.uk  
Web: www.linak.co.uk

## DISTRIBUTORS

Argentina  
Novotec Argentina SRL  
Phone: 011-4303-8989 / 8900  
Fax: 011-4032-0184  
E-mail: info@novotecargentina.com  
Web: www.novotecargentina.com

Colombia  
MEM Ltda  
Phone: +[57] (1) 334-7666  
Fax: +[57] (1) 282-1684  
E-mail: servicioalcliente@memlda.com.co  
Web: www.mem.net.co

India  
Mechatronics Control Equipments India Pvt Ltd  
Phone: +91-44-28558484, 85  
E-mail: bala@mechatronicscontrol.com  
Web: www.mechatronicscontrol.com

Indonesia  
PT. Himalaya Everest Jaya  
Phone: +6 221 544 8956 /+6 221 544 8965  
Fax: +6 221 619 1925  
Fax (Sales): +6 221 619 4658  
E-mail: hejplastic-div@centrin.net.id  
Web: www.hej.co.id

Israel  
NetivTech LTD  
Phone: +972 55-2266-535  
Fax: +972 2-9900-560  
Email: info@NetivTech.com  
Web: www.netivtech.com

Singapore  
Servo Dynamics Pte Ltd  
Phone: +65 6844 0288  
Fax: +65 6844 0070  
E-mail: servodynamics@servo.com.sg

South Africa  
Industrial Specialised Applications CC  
Phone: +27 011 466 0346  
E-mail: gartht@isagroup.co.za  
Web: www.isaza.co.za

United Arab Emirates  
Mechatronics  
Phone: +971 4 267 4311  
Fax: +971 4 267 4312  
E-mail: mechtron@emirates.net.ae

## Terms of use

LINAK® takes great care in providing accurate and up-to-date information on its products. However, the user is responsible for determining the suitability of LINAK products for a specific application. Due to continual development, LINAK products are subject to frequent modifications and changes. LINAK reserves the rights to conduct modifications, updates, and changes without any prior notice. For the same reason, LINAK cannot guarantee the correctness and actual status of imprinted information on its products.

LINAK uses its best efforts to fulfil orders. However, for the reasons mentioned above, LINAK cannot guarantee availability of any particular product at any given time. LINAK reserves the right to discontinue the sale of any product displayed on its website or listed in its catalogues or in other written material created and produced by LINAK, LINAK subsidiaries, or LINAK affiliates. All sales are subject to the 'Standard Terms of Sale and Delivery for LINAK A/S' available on LINAK websites. LINAK and the LINAK logotype are registered trademarks of LINAK A/S. All rights reserved.