

ELEVATE™

User Manual



Contents

Preface	3
Terms of use	4
Introduction	5
Safety instructions	6
Recommendations	8
Features	9
Options in general	9
Usage	9
Approvals	9
Speed and current curves	10
Motor current vs power supply current	10
Installation and usage guidelines	11
Stop time	11
Bending	12
Bending moment - Static	12
Bending moment - Dynamic	14
Built-in dimensions	15
LC3 IC mounting guidelines	15
Accessories	17
Cable set	17
Base plate	18
Accessory kits available for ELEVATE™	19
Cable set	19
ELEVATE Cobot kit	19
LC3 IC Mounting kit	19
Electrical installation	20
ELEVATE™ Modbus TCP/IP	21
Connection diagram	21
I/O specifications	22
Wiring example ELEVATE™ Modbus TCP/IP	23
Universal Robots cobots with ELEVATE Modbus TCP/IP	23
OMRON TM cobots with ELEVATE Modbus TCP/IP	23
Kassow cobots with ELEVATE Modbus TCP/IP	24
Contacts	27

Preface

Dear User,

We are delighted that you have chosen a LINAK® product.

LINAK systems are high-tech products based on many years of experience in the manufacture and development of actuators, lifting columns, desk frames, electric control boxes, controls, batteries, accessories and chargers.

This User Manual does not address the end user. It is intended as a source of information for the equipment or system manufacturer only, and it will tell you how to install, use and maintain your LINAK electronics. The manufacturer of the end product has the responsibility to provide a User Manual, where relevant safety information from this manual is passed on to the end user.

We are convinced that your LINAK product/system will give you many years of problem-free operation.

Before our products leave the factory, they undergo both function and quality testing. Should you, nevertheless, experience problems with your product/system, you are always welcome to contact your supplier.

LINAK subsidiaries and some distributors situated all over the world have authorised service centres, which are always ready to help you. Locate your local contact information on the back page.

LINAK provides a warranty on all products. (See warranty section).

This warranty, however, is subject to correct use in accordance with the specifications, maintenance being done correctly, and any repairs being carried out at a service centre, which is authorised to repair LINAK products.

Changes in installation and use of LINAK systems can affect their operation and durability. The products may only be opened by authorised personnel.

This User Manual has been written based on the present technical knowledge. LINAK reserves the right to carry out technical modifications and keeps the associated information updated.

LINAK A/S

Terms of use

LINAK® takes great care in providing accurate and up-to-date information on its products. However, the user is responsible for determining the suitability of LINAK products for a specific application.

Due to continual development, LINAK products are subject to frequent modifications and changes. LINAK reserves the rights to conduct modifications, updates, and changes without any prior notice. For the same reason, LINAK cannot guarantee the correctness and actual status of imprinted information on its products.

LINAK uses its best efforts to fulfil orders. However, for the reasons mentioned above, LINAK cannot guarantee availability of any particular product at any given time. LINAK reserves the right to discontinue the sale of any product displayed on its website or listed in its catalogues or in other written material created and produced by LINAK, LINAK subsidiaries, or LINAK affiliates.

All sales are subject to the 'Standard Terms of Sale and Delivery for LINAK A/S' available on LINAK websites.

LINAK and the LINAK logotype are registered trademarks of LINAK A/S. All rights reserved.

Introduction

The LC3 IC is a smart electric lifting column featuring an integrated controller that allows for seamless connectivity in industrial applications through a variety of interfaces. Designed and field-tested for robust, long-lasting performance, the LC3 IC is a reliable solution for your vertical lift applications.

The LC3 IC is an ideal choice for automation technology that streamlines processes between machines and improves the working environment. And if your application requires a strong foundation for managing high loads and enhancing stability, you can run several columns in parallel.

Speed up your development with these benefits:

- Three-stage telescopic design: High performance in a compact size – flexible mounting in both vertical directions
- Many customisation options: 400–1,100 mm stroke lengths, 24 or 48 V, up to 6,000 N loads, and up to 100 mm/s
- Integrated Controller: Direct control over a wide range of industrial PLCs
- Brushless DC motor: Smooth movement and long service life
- Status LED and diagnostics: Easy troubleshooting to increase up-time

With its quiet operation, this discreet electric lifting column also enhances the work environment.

Safety instructions

Please read this safety information carefully.

Be aware of the following three symbols throughout the document:



Warning!

Failing to follow these instructions can cause accidents resulting in serious personal injury.



Recommendations

Failing to follow these instructions can result in the product suffering damage or being ruined.



Additional information

Usage tips or additional information that is important in connection with the use of the product.

Furthermore, ensure that all staff who are to connect, mount, or use the product are in possession of the necessary information and that they have access to this document.

Persons who do not have the necessary experience or knowledge of the product/products must not use the product/products. Besides, persons with reduced physical or mental abilities must not use the product/products, unless they are under surveillance or they have been thoroughly instructed in the use of the apparatus by a person who is responsible for the safety of these persons.

Moreover, children must be under surveillance to ensure that they do not play with the product.



Warnings

- Always use a cable lock to ensure cables are fixed and not squeezed, pulled, or subjected to stress or damage.
- Make a proper cable installation and inspect regularly for wear, damage, and jarring sounds to avoid cable interruption and lifting column defects. Defective parts must be replaced.
- Damaged parts can cause moisture to gather and lead to dangerous electrical connections between metal parts and wires.
- Always check correct assembly after mounting or service and ensure the cable lock is fitted.
- Do not exceed the max. nominal pull or push load specified on the label.
- Do not add dynamic load when changing between pull and push.
- Do not manually adjust anything during movement or while connected to power supply unit, as this may cause personal injury.
- Cables must remain plugged in the column during cleaning to prevent water ingress.
- After service inspection, the application must be tested for correct functionality before use to avoid misalignment between two or more columns moving in parallel.
- If LC3 IC is used in ceiling-hang applications, consider if additional third-party safety devices are required to prevent personal injuries.
- Not to be used horizontally.
- The product is NOT to be opened by unauthorized personnel.
- LC3 IC is heavy (more than 20 kg). To avoid personal injury and product damage, DO NOT DROP!
- Do not loosen any screws on the LC3 IC, as this can cause collapse of the column!
- The lifting column can become a functional safety system compliant with EN ISO10218-2. To integrate the LC3 IC into a functional safety chain, external safety devices such as safety contactors/relays must be implemented.
- Pinching Hazard Warning: Be aware of the risk of pinching during column movement. If a top plate larger than the smallest profile is mounted, it poses a pinching risk for objects higher than 4 cm. Additionally, mounting the column upside down at ground level creates a pinching hazard at the moving profile ends. Please implement appropriate safeguards to prevent injury.



Recommendations

- Always follow the important LC3 IC mounting guidelines and LINAK specifications to ensure correct functionality.
- Self-designed mounting plates must cover the entire bottom plate and be strong enough to carry the load.
- Do not use chemicals for cleaning nor remove sliders grease on profiles.
- Intended for indoor use only and not for use in harsh environments like pool or marine environments and agriculture buildings with ammonia vapours.
- Assure free space for movement of the application in both directions to avoid blockage.
- Listen for unusual sounds and watch for uneven running during operation. Stop the lifting column immediately if anything unusual is observed.
- When using Actuator Connect™ to modify parameters, please proceed at your own risk. Ensure that the soft start and soft stop times are set to no less than 500 milliseconds (1,500 ms for the 1,000 N version).
- Avoid dynamic load changes while the column is operating, as moving loads can increase the total load beyond the column's specifications, potentially shortening its lifespan and causing stick-slip issues.
- For applications with suitable built-in dimensions, we recommend heavy-duty profiles due to their enhanced resistance to side forces and bending moments, especially under off-center loads. Standard profiles are ideal for applications requiring compact dimensions without off-center loads.
- Avoid clamping the column on the outer profile, as this can alter the system's internal friction and negatively affect the column's lifespan.
- Avoid placing the column in dusty environments, as this can impact the sliders and reduce the column's lifespan. If a dusty environment is unavoidable, use a cover solution to protect the column.

Features

- Position accuracy: +/- 1.5 mm
- Profile colour: Anodised aluminium
- Top and bottom plate colour: Zinc grey bottom plate / zinc grey top plate
- Built-in dimensions: Stroke/2 + 280 mm - min. BID is 400/2 + 280 = 480 mm
- Dynamic bending moment: Up to 1,400 Nm (allowed bending moment between cobot and column while the column is running in or out)
- Static bending moment: Up to 3,000 Nm (allowed bending moment between cobot and column while the column is not moving)
- Protection class: IP4X
- Noise level: Max. 58 dB (A)
- Weight: 29 kg with 900 mm stroke

Options in general

- 24 V DC Brushless motor
- 1,000 N load in push and pull
- Max. speed: 100 mm/sec (adjustable and independent of load)
- Stroke length from 400 mm to 1,100 mm in steps of 100 mm
- IC options:
 - Modbus TCP/IP

Usage

- Duty cycle is max. 20% (4 min. drive and 16 min. rest) at full load and 25°C ambient temperature
- Current consumption: 20 A (Supply)
- Operation temperature: +5°C to +40°C
- Storage temperature: -40°C to +70°C
- Relative humidity: 20% to 80% - non-condensing
- Atmospheric pressure: 700 to 1,060 hPa
- Metres above sea level: Max. 3,000 metres

Approvals

- BS EN 61000-6-2:2019 - Part 6-2
- BS EN 61000-6-4:2019 - Part 6-4

Speed and current curves

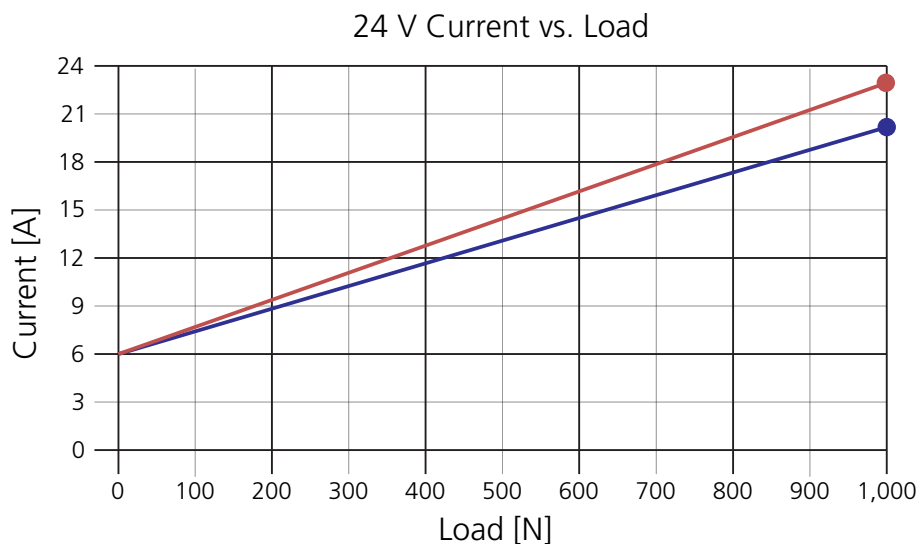
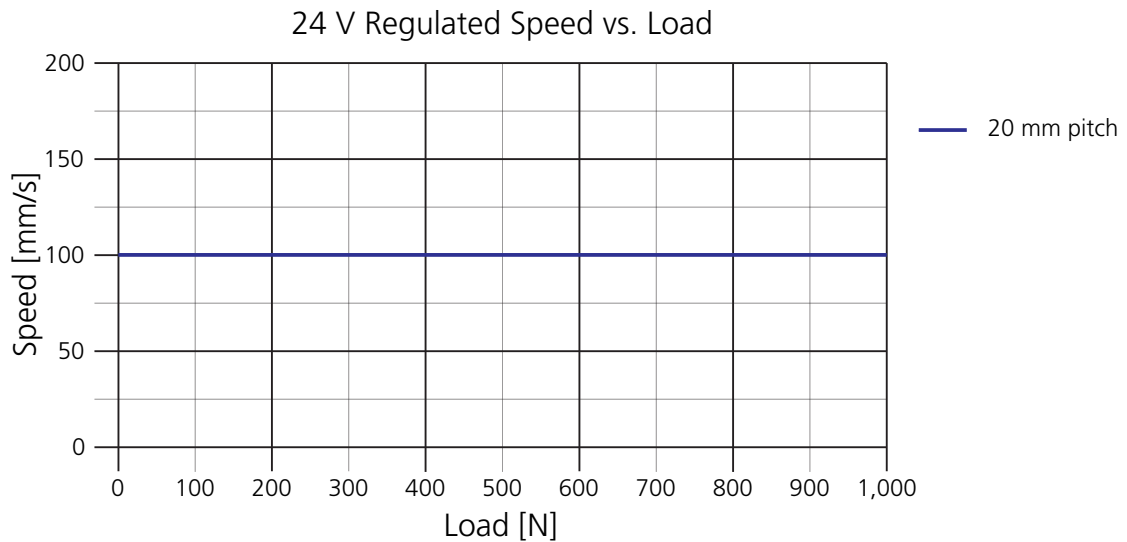

● Minor side load during extension* ● High side load during extension**

* The cobot and the load is positioned around the centre of the column during extension.

** The cobot and the load can be freely positioned, placed, or moved during extension.

Motor current vs power supply current

When choosing a suitable power supply, please be aware of how the lifting column current consumption is defined. The current feedback from the lifting column via bus communication and the Actuator Connect™ service tool can appear higher than the current measured at your power supply. This is due to the way the lifting column speed is regulated and can affect the expected result of a set current limit. The internal current limit is based on the motor current and not the current of the power supply.

Example:

If the power supply current reads 16 amps, the motor current may be measured to 19 amps due to the speed regulation. The set current limit is based on the motor current and if set to 18 amps, it can trigger an overcurrent state even though the power supply current is at 16 amps.

Installation and usage guidelines

Before mounting/dismounting the lifting column, ensure that the following points are observed:

- The lifting column is not in operation.
- The lifting column is free from loads that could be released during this work.

Before the lifting column is being put into operation, check the following:

- The lifting column is correctly mounted as indicated in the relevant user instructions.
- The equipment can be freely moved over the lifting column's whole working area.
- The lifting column is connected to a mains electricity supply/transformer with the correct voltage, and which is dimensioned and adapted to the lifting column in question.
- The voltage applied matches the voltage specified on the lifting column label.
- The connection screws are secured safely.

During operation:

- Periodically run the column through the stroke area between 35 mm and 70 mm. This is the calibration zone for the Zero Point. When the column moves through this area, the controller will automatically calibrate the incremental encoder feedback system. This process corrects any offset that may occur from column sinking or movement without power.
- If you observe black or dark stripes on the column, it is likely due to dust or small particles on the slide. Avoid placing the column in very dusty environments, as this can affect the sliders and reduce the lifespan of the column. Use a cover solution if a dusty environment is unavoidable.
- For the best accuracy, always move to the desired position from the same direction.
- Ensure that the LC3 IC has a load of minimum 100 N. Failure to meet this requirement may cause the column to shift between pulling and pushing, which can impact the accuracy negatively.

Stop time

When the speed of the column is reduced or the motor power is removed, the brake will engage and stop the column and self-lock it. The following table shows the stop time when a stop signal is sent or the motor power is removed:

Interface	Soft stop when stop signal is sent	Stop time by power loss
ELEVATE™ Modbus	1,500 ms	500 ms



Ensure that the soft start and soft stop must be no less than 1,500 milliseconds. Setting stop times too short can cause the back electromotive force of the motor to damage the integrated controllers of the columns.

Bending

Bending moment - Static

The maximal bending moment for static column use is 3,000 Nm. Static column use is when the column is not moving and e.g. the cobot creates a bending moment.

High off-centre loads apply bending moments onto the lifting column and cause bending of the column. The following graph shows the expected bending for different bending moments (M_B , M_T) and strokes. The data is representative for columns with 900 mm stroke. Runtime has an impact on the bending of the column. The graphics show the bending for a new column with 900 mm stroke (0.1 km runtime), a new column with 1,100 mm stroke, and a used 900 mm stroke column (135 km runtime). The used column ran 135 km with a constant off-centre of 100 kg and a bending moment of 350 Nm.

It might appear that the column has a greater bending when high bending moments are applied. However, this is mainly caused by the bending of the basis on which the column is mounted. Small bending on the basis causes greater bending of the whole application. Make sure your basis is resilient enough to withstand forces from the column and cobot.

For heavy cobots like UR20, H2017 etc., we recommend running the cobot at default collaborated speed and acceleration to avoid vibrations in the system and ground. Too fast acceleration and deceleration negatively affect position accuracy and lifetime of the column and robot. Examples of default collaborated speed are:

- Speed $60^\circ /s$ (joint movement)
- Acceleration $80^\circ /s^2$ (joint movement)

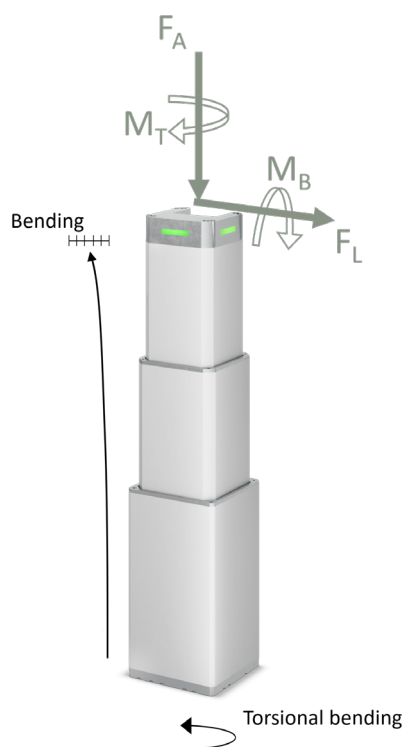

Bending with bending moment M_B

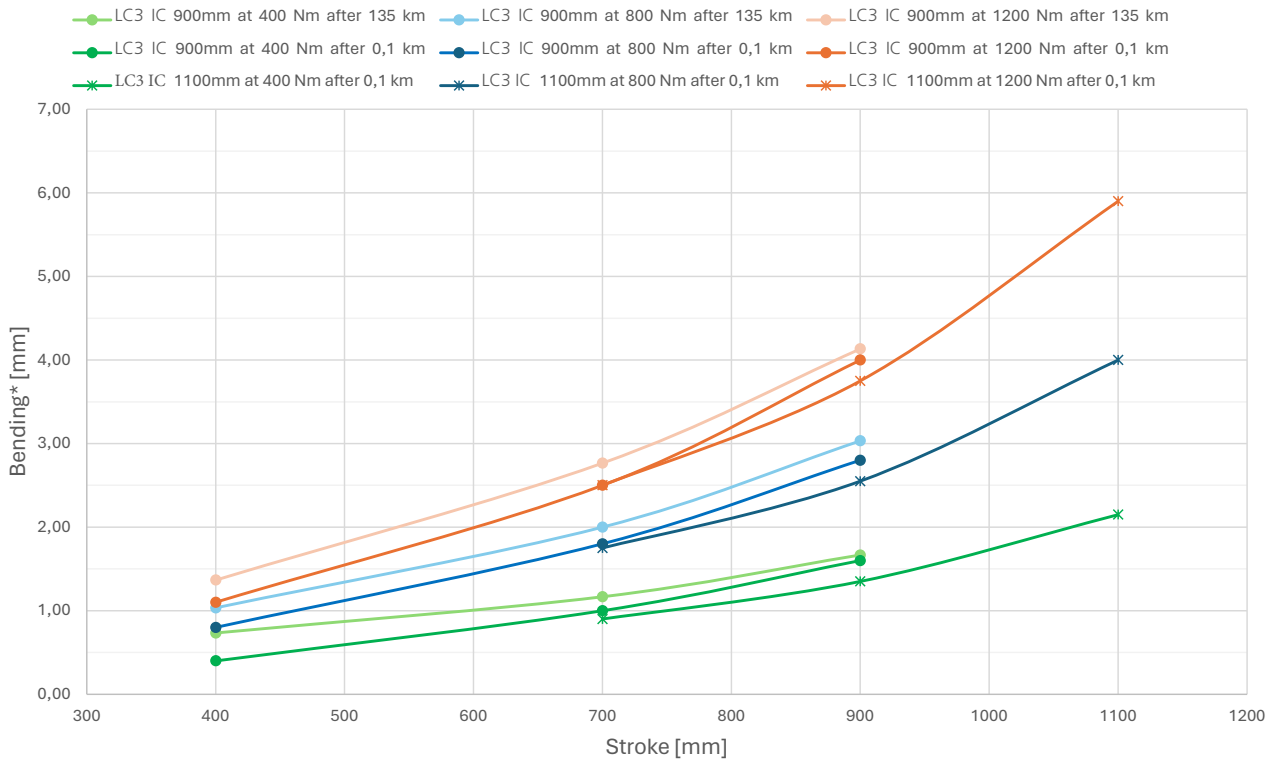

* The bending is measured at the top of the column in a horizontal direction.

Bending with torsional moment M_T

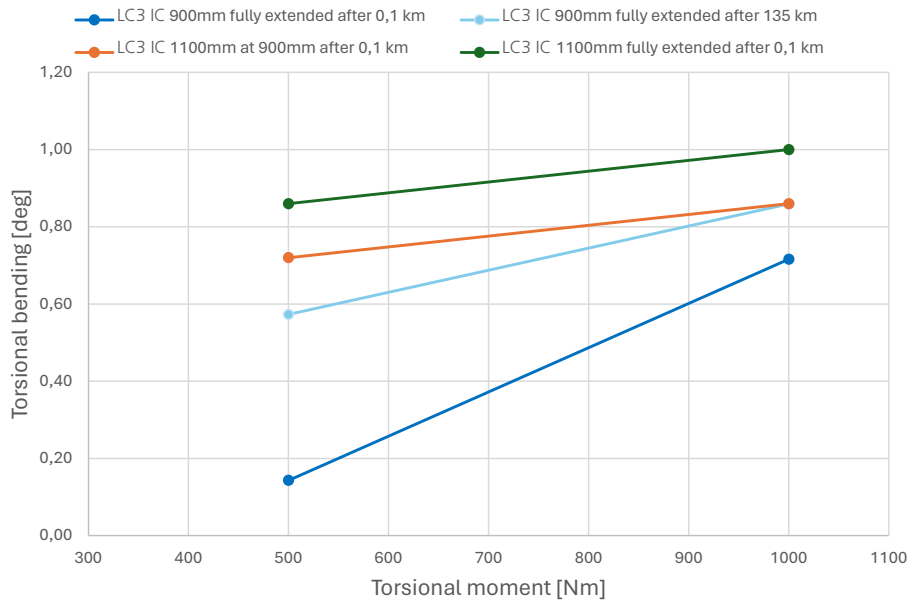

Bending moment - Dynamic

The maximal bending moment for dynamic column use is 1,400 Nm. This value must not be exceeded while the column is running in or out. In general, it is recommended to retract or partially retract the cobot while the column is running. Do not operate the column while the cobot arm is fully extended.

A fully horizontal extended cobot can cause a stick and slip effect at the last 200 mm of stroke (for 900 mm stroke: between position 700 mm and 900 mm) during downward movement of the column. Stick and slip is the result of an interplay between sliding friction and static friction between sliders and aluminium profiles inside the lifting column. This is caused by a too high bending moment and the absence of downwards force on the column. The result is short start/stop movements, which should be avoided during operation.

If off-centre load is applied to an LC3 column, final testing and approval by the customer is recommended, as stability and performance depend on each specific customer application.

The following two graphs show the stick and slip areas for ELEVATE™ with 900 mm and 1,100 mm stroke.

ELEVATE with 900 mm stroke:

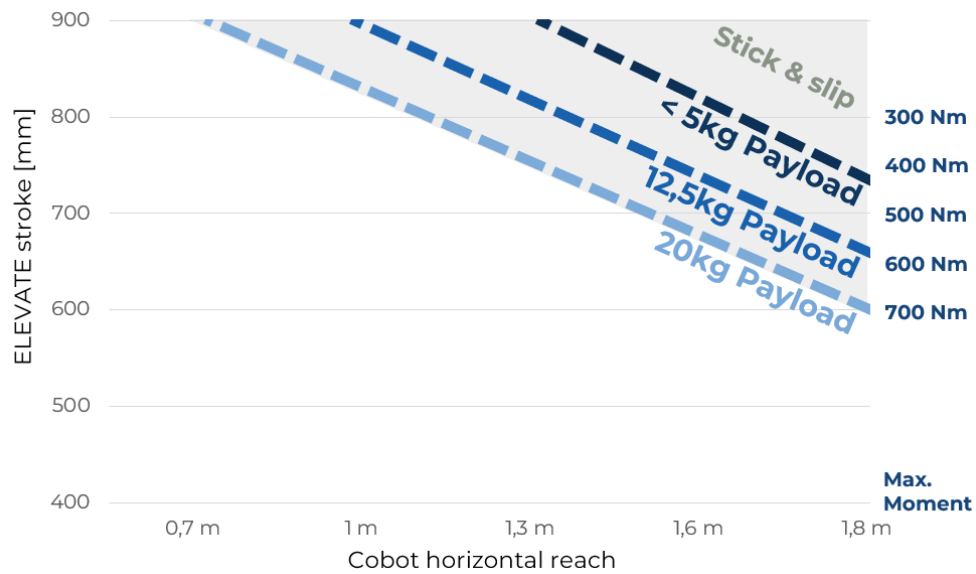

No stick and slip below 600-700 mm (depending on load)

ELEVATE with 1,100 mm stroke and improved stick and slip:

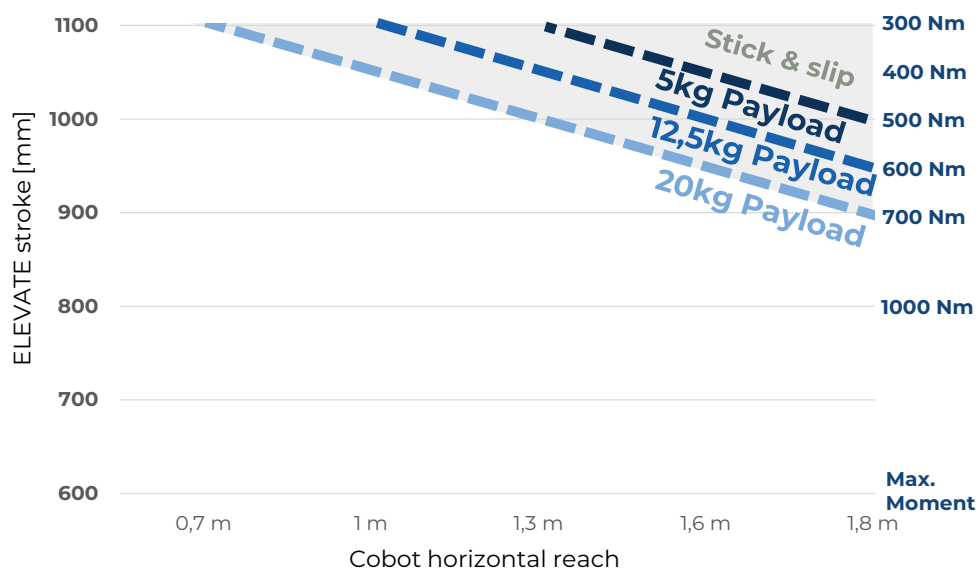

No stick and slip until 900 mm stroke.

Built-in dimensions

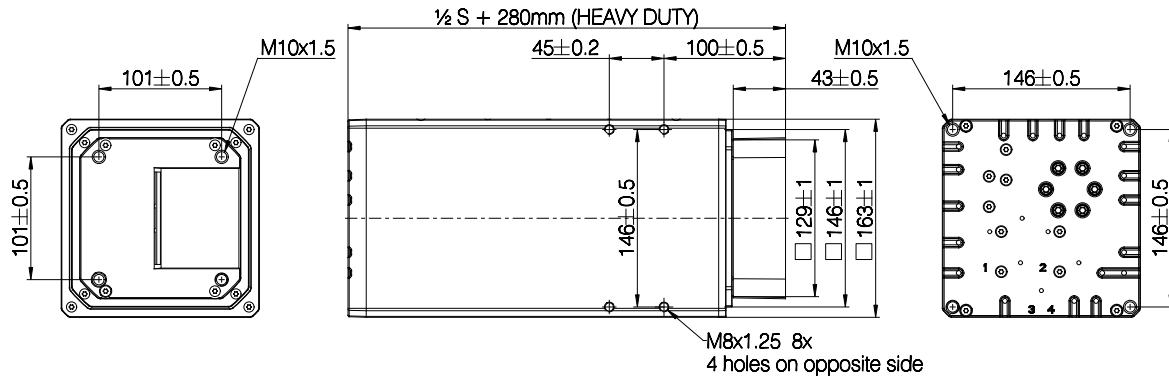

ELEVATE™ comes with 8 M8 mounting holes on the outer profile.

LC3 IC mounting guidelines

LC3 IC is for use in push and pull applications and can be mounted right-side up or in an upside down position. The column can only be used for vertical movement, not horizontal.

Upside down Right-side up



Note: The cable outlet for motor connection is positioned at the top (smallest profile)
Mount the LC3 IC in the application using the 4x M10 mounting holes in both end plates.

If the column is to be used with a constant high off-centre load, we recommend to install the constant weight in one of the 3 ways illustrated by the green symbols. It is not recommended to install the weight on the opposite side of the mechanical endstop as illustrated with the red symbol. This installation can create an uneven movement and noise when the lifting column reaches the endstop position.

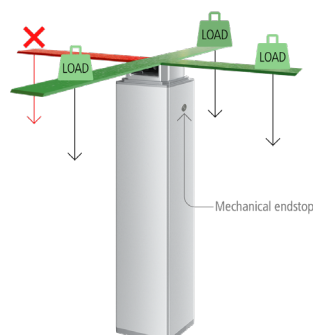

LC3 IC mounting guidelines

Use 4 pcs. M10 8.8 bolts at each end of the column for mounting to the application.
The screw depth must be min. 20 mm and max. 30 mm in the aluminium profile.

Screw torque: 35 Nm.

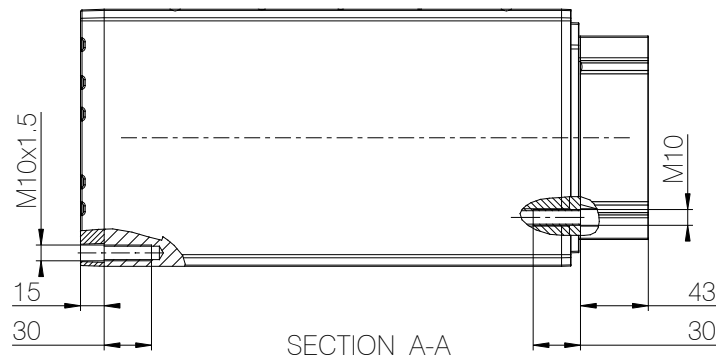

15 mm distance to thread

Bolt depth min. 20 mm

43 mm distance to thread

Mounting holes

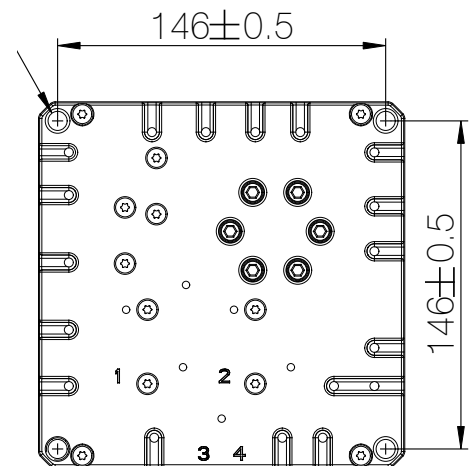
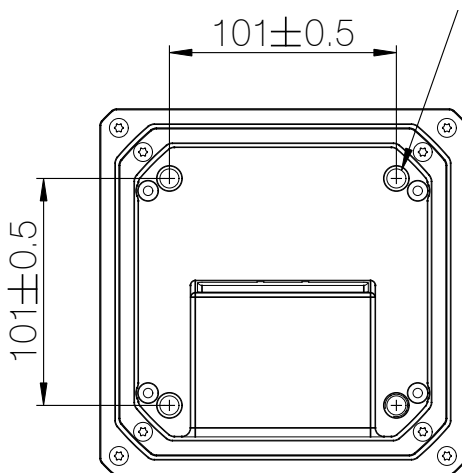

- It is recommended to use bolts with thread-lock adhesive
- Bolts of high quality steel 8.8 or 10.9 must be used to secure safe mounting of the LC3 IC to the application.

Accessories

ELEVATE™ is the cobot option for LC3 IC. There are different accessories available to simplify the integration with compatible cobot brands. Plug-in software is freely available on LINAK.com.



Cable set

The set includes a 5 m power cable, a 5 m signal cable, and a cable lock with a mounting screw. The cable set is required for the electrical installation of an LC3 IC.



The internal bending radius of the cables must be bigger than 3 times the outer dimension of the cable.

For instance, if the outer cable dimension is $\varnothing 7$, the internal radius of the maximum cable bending is 21 mm.

Base plate

The base plate is the standard bottom plate for LC3 IC to mount the column to the base of your application. It is important to use a solid ground since deflections on the ground influence the precision of the whole system. The steel plate can also be used to mount on the top of the column. Drawings can be downloaded from LINAK.com

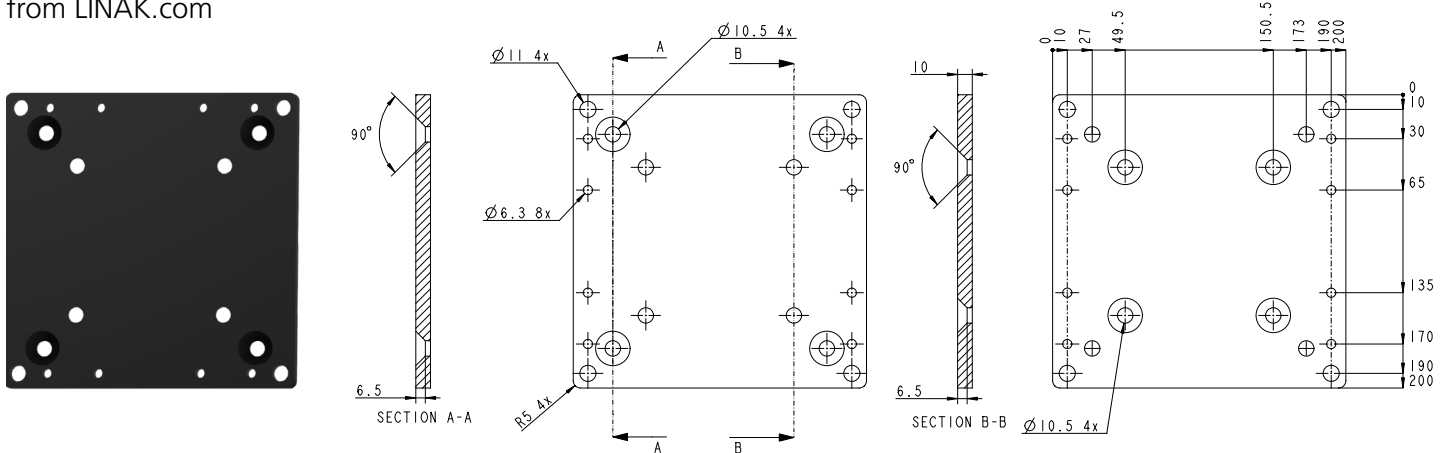

ELEVATE™ Universal Mounting Plate

The universal mounting plate is compatible with most cobot brands. The aluminium plate comes with 2 additional M6 x 1.0 holes to mount an energy chain. Drawings can be downloaded from LINAK.com

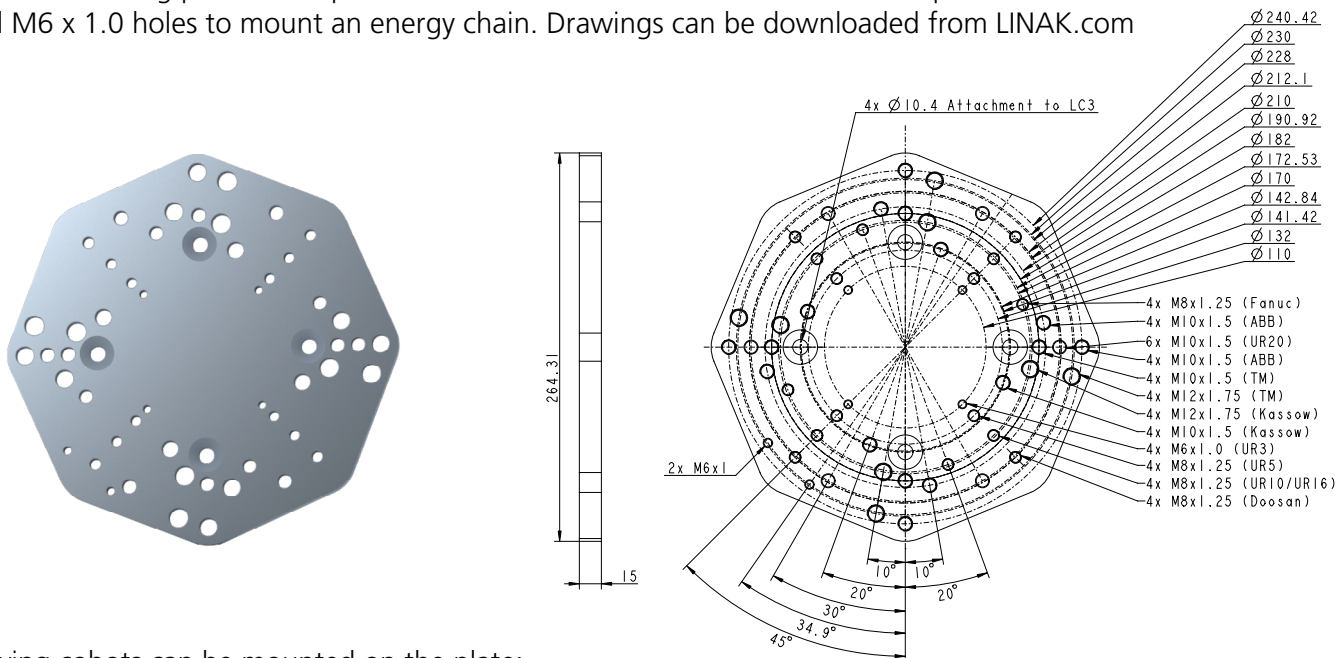

The following cobots can be mounted on the plate:

Cobot brand	Cobot model
Universal Robots	UR3, UR5, UR10, UR16, UR20, UR30
Doosan	H2017, H2515, M-series
OMRON/TECHMAN	TM12, TM14, TM16, TM20, TM25
FANUC	CRX-10iA, 10 iA/L, 20 iA/L
JAKA	Pro12, Zu 12, Zu 18, Zu 3
AUBO	Not compatible
DOBOT	CR5, CR7, CR10, CR12, CR16, A and S-series, CR20A
Yaskawa	Not compatible
Kassow	KR810, KR1205, KR1018, KR1410, KR1805
ABB	GoFa5, GoFa10, GoFa12
KUKA	Not compatible
ELITE	CS612, CS620, CS625
Hanwha	HCR-12A

Accessory kits available for ELEVATE™

Cable set

Article number: 1002W8165

Description	Quantity
Power cable, 5 m, 6-pin minifit	1
Signal cable, 5 m, 9-pin microfit	1
Cable lock with mounting screw T15	1

ELEVATE Cobot kit

Article number: 1002W8191

Description	Quantity
Power cable, 5 m, 6-pin minifit	1
Signal cable, 5 m, 9-pin microfit	1
Cable lock with mounting screw T15	1
Base screw M10 x 45 A2 ISO 10642	4
Base plate	1
Top screw M10 x 80 A2 ISO 10642	4
ELEVATE Universal mounting plate	1

LC3 IC Mounting kit

Article number: 1002W8192

Description	Quantity
Power cable, 5 m, 6-pin minifit	1
Signal cable, 5 m, 9-pin microfit	1
Cable lock with mounting screw T15	1
Base screw M10 x 45 A2 ISO 10642	4
Base plate	2
Top screw M10 x 80 A2 ISO 10642	4

Electrical installation

The default soft stop on the column will send a short peak of higher voltage back towards the power supply. It is important when selecting the power supply that it does not turn off the output, when this backwards load dump occurs.



The power supply should not be able to supply more than 700 Watt to 1,000 N columns. A power supply above 700 Watt has a negative effect on the lifetime of the column if the column runs several times into the mechanical endstop.



The top and the bottom of the column are **not** interconnected with a ground cable.



1. Power connector: The 6-pin connector is for the power supply. It uses a CAB0367046-xxxx cable.
2. Signal connector: The 9-pin connector is used for controlling the LC3 IC, obtaining position information, and supplying power to the communication controller. It requires a CAB0368543-xxxx cable, which should be connected to the PLC of the application.
3. Ethernet connector: The RJ45 connector is used for the Ethernet communication. It requires a shielded (STP) Cat6 Ethernet cable or a cable suitable for the required transmission speed.



For detailed information on pin configurations and I/O specifications, please refer to the interface user manuals available at LINAk.com

When connecting the power and signal cables to the lifting column, use the cable lock to secure them. Tighten the screw with a Torx bit T15 screwdriver to 1.6 Nm.

The signal connector provides access to Actuator Connect™. Additional information can be found in the interface manuals at LINAk.com

ELEVATE™ Modbus TCP/IP

Connection diagram

Platform: OE

BROWN	24 V DC
BLUE	GND

RED	Extends the column
BLACK	Retracts the column
ORANGE	Split power supply V DC

Power Cable



Flying Leads

Signal Cable

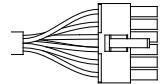

Flying Leads
(Molex mini-fit 12-pin)

Ethernet

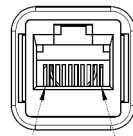

8 1

RJ45



Please be aware that if the power supply is not properly connected, you might damage the column!



For detailed information about the interface, please read the [Modbus TCP/IP Interface user manual](#).

ELEVATE™ Modbus TCP/IP

I/O specifications

Input/Output	Specification	Comments
Description	<p>Easy-to-use interface with integrated power electronics.</p> <p>Uses Modbus TCP/IP messages to command movement, set parameters, and to deliver feedback from the lifting column.</p>	
Brown	<p>24 V DC + (VCC)</p> <p>24 V ± 10 %, motor current limit: 25 A</p> <p>Connect Brown to positive</p>	<p>Note:</p> <p>Do not change the power supply polarity on the Brown and Blue wires!</p> <p>Power supply GND (-) is electrically connected to the housing.</p>
Blue	<p>24 V DC - (GND)</p> <p>Connect Blue to negative</p>	
Red	Extends the column	<p>The signal becomes active at:</p> <p>> 67% of V_{IN}</p> <p>The signal becomes inactive at:</p> <p>< 33% of V_{IN}</p>
Black	Retracts the column	<p>Input current: 10 mA</p> <p>The column comes with a 1,500 ms soft stop and start.</p> <p>Only available if Ethernet communication is established.</p>
Yellow	Not to be connected	
Green	Not to be connected	
Orange	Split power supply V DC	<p>24 V DC with ≈28 mA current consumption.</p> <p>The split power supply uses the common GND from the power supply (Blue).</p> <p>Split power supply is only for powering the communication of the integrated controller.</p>
Light Blue	Not to be connected	
Violet	Not to be connected	
White	Not to be connected	
Grey	Not to be connected	



Current cut-offs should not be used as stop function! This might damage the column. Current cut-offs should only be used in emergencies!

Current cut-off limits are not proportional with the load curves of the column. This means that the current cut-offs cannot be used as load indicator.

There are tolerances on the spindle, nut, gear wheels etc. and these tolerances will have an influence on the current consumption for the specific column.

Wiring example ELEVATE™ Modbus TCP/IP

Universal Robots cobots with ELEVATE Modbus TCP/IP

ELEVATE Modbus TCP/IP can be directly used with a UR cobot due to the ELEVATE URcap. ELEVATE Modbus TCP/IP is recommended when the cobot needs to be positioned at several positions within the column's stroke. Connect the column to the UR control box as shown in the wiring diagram. ELEVATE does not come with safety relay/contactors nor power supply. The wiring diagram only shows a suggestion to integrate ELEVATE into a safe torque off system.

Download the ELEVATE URcap from LINAK.com and get more information.

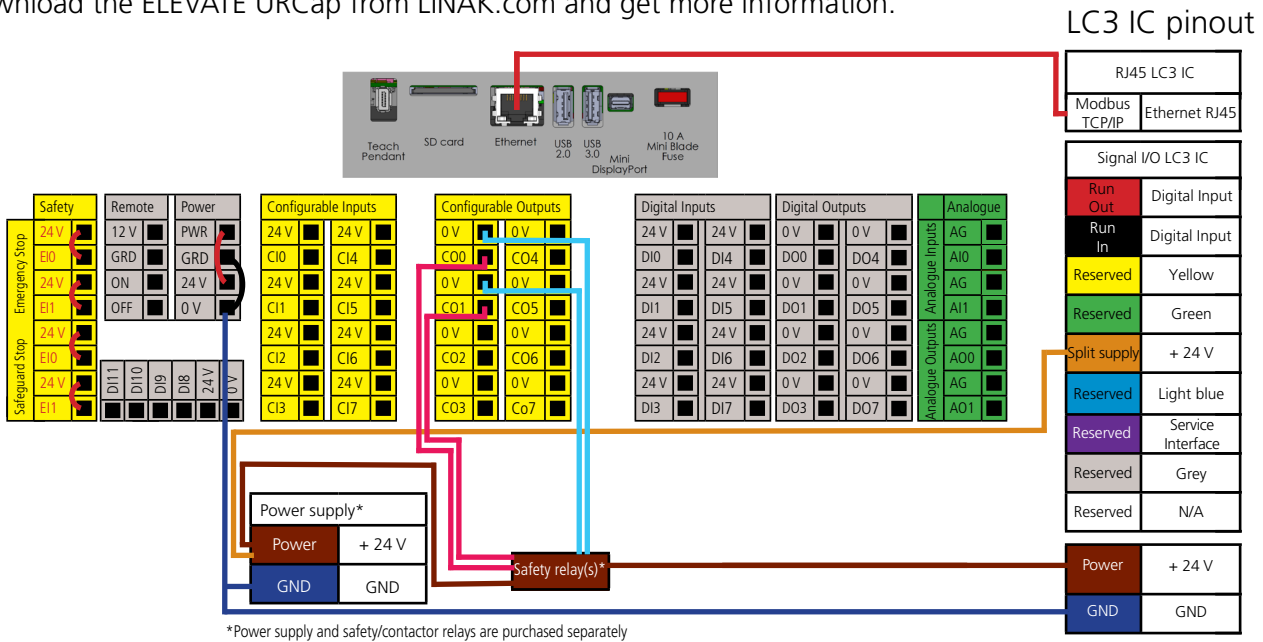

OMRON TM cobots with ELEVATE Modbus TCP/IP

ELEVATE Modbus TCP/IP can be directly used with an OMRON TM cobot due to ELEVATE components for TMFlow. Connect the column to the TM control box as shown in the wiring diagram. ELEVATE does not come with safety relay/contactors nor power supply. The wiring diagram only shows a suggestion to integrate ELEVATE into a safe torque off system.

Download the ELEVATE components for TMFlow from LINAK.com and get more information.

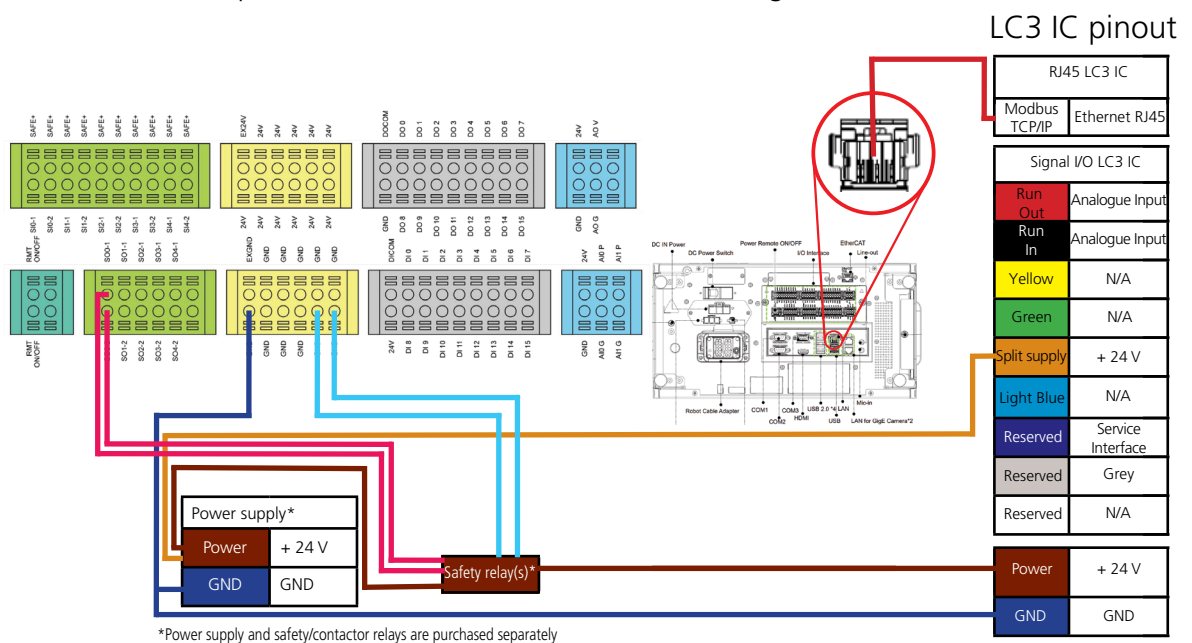

Wiring example ELEVATE™ Modbus TCP/IP

Kassow cobots with ELEVATE Modbus TCP/IP

ELEVATE Modbus TCP/IP can be directly used with Kassow cobots with the ELEVATE Cbun.

Connect the column to the Kassow controller as shown in the wiring diagram. ELEVATE does not come with safety relay/contactors nor a power supply. The wiring diagram only shows a suggestion to integrate ELEVATE into a safe torque off system.

Download the ELEVATE Cbun from LINAK.com and get more information.

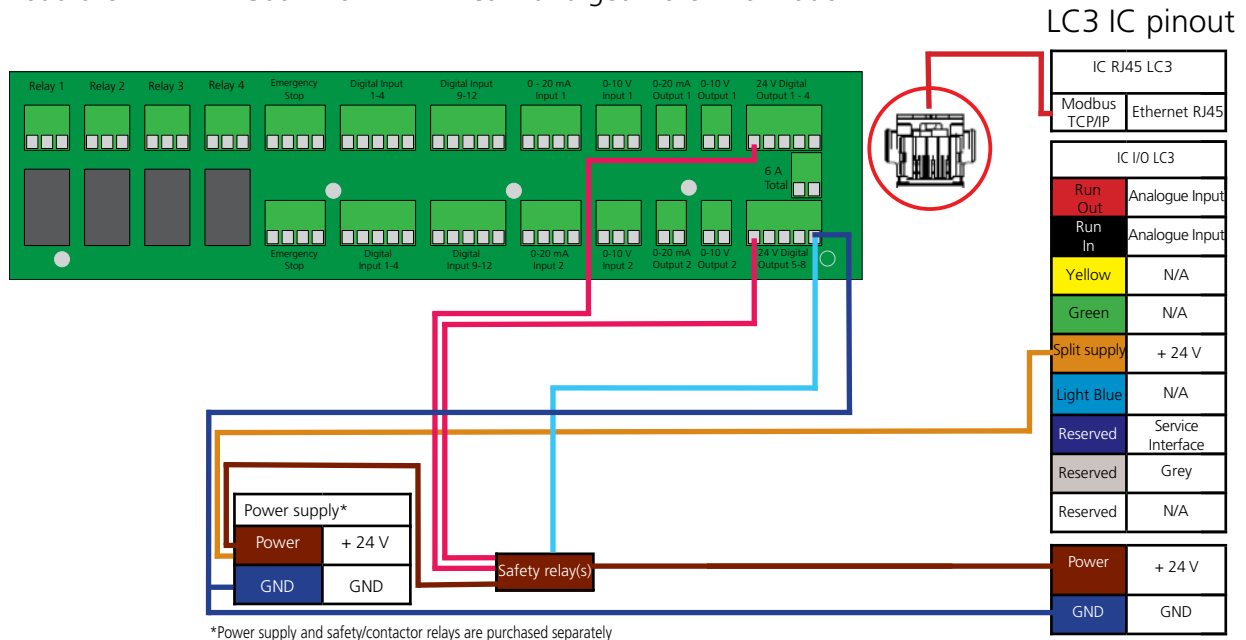

*Power supply and safety/contactors relays are purchased separately



DECLARATION OF CONFORMITY

LINA K A/S
Smedevænget 8
DK - 6430 Nordborg

Hereby declares that LINA K Lifting Column:

LC3*****3**_***

(The * in the product description can either be a character or a number, thereby defining the variation of the product)

complies with the EMC Directive 2014/30/EU according to following standards:

EN 55016-2-3:2017+A1+A2, EN 55016-2-1:2014+A1
 EN 61000-4-2:2009, EN IEC 61000-4-3:2020, EN 61000-4-4:2012
 EN 61000-4-5:2014+A1, EN 61000-4-6:2014, EN 61000-4-8:2010

complies with RoHS2 Directive 2011/65/EU according to the standard:
 EN IEC 63000:2018

Additional information:

The product does comply with selected parts of the standards:

EN 61000-6-2:2019, Electromagnetic compatibility (EMC) – Part 6-2: Generic standards – Immunity for industrial environments
 EN 61000-6-4:2019: Electromagnetic compatibility (EMC) – Part 6-4: Generic standards – Emission standard for industrial environments

DK-6430 Nordborg, 2024-05-31

LINA K A/S
 John Kling, B.Sc.E.E.
 Regulatory Affairs Manager
 Authorized to compile the relevant technical documentation

This declaration of conformity is issued under the sole responsibility of the manufacturer.
 Original Declaration

DECLARATION OF INCORPORATION OF PARTLY COMPLETED MACHINERY

LINAK A/S
Smedevænget 8
DK - 6430 Nordborg

LINAK A/S hereby declares that LINAK DESKLINE® products, characterised by the following models and types:

Control Boxes	CBD6S
Linear Actuators	DB5, DB6, DB14, LA23, LA31
Lifting Columns	DL1A, DL2, DL4S, DL5, DL6, DL8, DL9, DL10, DL11, DL12, DL14, DL15, DL16, DL17, DL18, DL19, DL20, DL21, BASE1, LC1
Desk Panels	DPA, DPB, DPH, DPF, DPG, DPT, DP, DP1CS, DPI
Wireless Controls	BP10
Accessories	BA001, BLE2LIN, CHUSB, DESK Sensor, DF2, Kick & Click, SLS, SMPS, USB2LIN, WiFi2LIN, DC Connector, RFRL

LINAK A/S hereby declares that LINAK HOMELINE® products, characterised by the following models and types:

Control Boxes	CBD6DC
Linear Actuators	LA10, LA18, LA40 HOMELINE
Dual Actuators	TD4, TD5
Controls	BP10, HC10, HC20, HC40
Accessories	BA002, CP, BLE2DC, BLE2LIN, LED Light Rail, MD1, SMPS, WiFi2LIN

LINAK A/S hereby declares that LINAK MEDLINE® & CARELINE® products, characterised by the following models and types:

Control Boxes	CA10, CA20, CA30, CA40, CA63, CAL40, CB6, CB6S, CB6P2, CB8, CB9, CBJ2, CBJ Care, CBJ Home, CO41, CO53, CO61, CO65, CO71, COL50, OPS, PJ2, PJB4
Linear Actuators	LA20, LA23, LA24, LA27, LA28, LA29, LA30, LA31, LA34, LA40, LA44
Lifting Columns	BL1, LC1, LC3
Controls	ABL, ACC, ACK, ACO, ACOM, ACL, DP, DPH, FS, FS3, FPP, HB30, HB70, HB80, HB100, HB190, HB200, HB400, HD80, HL70, HL400
Accessories	BA16, BA18, BA19, BA22, BAJ, BAJL, BAL40, BAL50, CH01, CHJ2, CHL40, CHL50, DJB, LIN2OB, MJB2, MJB5 Plus, Massage Motor, PJB4, QLCI2, SLS, SMPS10, UBL, UBL2, UBL4 Motion, USB-A Power Adapter

LINAK A/S hereby declares that LINAK TECHLINE® products, characterised by the following models and types:

Linear Actuators	LA12, LA14, LA23, LA25, LA30, LA33, LA35, LA36, LA37, LA76, LA77
Lifting Columns	LC3 IC
Accessories	FMB

comply with the following parts of the Machinery Directive 2006/42/EC, ANNEX I, Essential health and safety requirements relating to the design and construction of machinery: 1.5.1 Electricity supply

The relevant technical documentation is compiled in accordance with part B of Annex VII and this documentation or part hereof will be transmitted by post or electronically to a reasoned request by the national authorities.

This partly completed machinery must not be put into service until the final machinery into which it is to be incorporated has been declared in conformity with the provisions of the Machinery Directive 2006/42/EC where appropriate.

Nordborg, 2024-07-10

John Kling

LINAK A/S

John Kling, B.Sc.E.E., Certification and Regulatory Affairs
Authorised to compile the relevant technical documentation

Original declaration

Contacts

FACTORIES

Denmark - Headquarters
LINAK A/S
Phone: +45 73 15 15 15
Fax: +45 74 45 80 48
Fax (Sales): +45 73 15 16 13
Web: www.linak.com

China
LINAK (Shenzhen) Actuator Systems, Ltd.
Phone: +86 755 8610 6656
Phone: +86 755 8610 6990
Web: www.linak.cn

Slovakia
LINAK Slovakia s.r.o.
Phone: +421 51 7563 444
Web: www.linak.sk

Thailand
LINAK APAC Ltd.
Phone: +66 33 265 400
Web: www.linak.com

USA
LINAK U.S. Inc.
Americas Headquarters
Phone: +1 502 253 5595
Fax: +1 502 253 5596
Web: www.linak-us.com
www.linak-latinamerica.com

SUBSIDIARIES

Australia
LINAK Australia Pty. Ltd
Phone: +61 3 8796 9777
Fax: +61 3 8796 9778
E-mail: sales@linak.com.au
Web: www.linak.com.au

Austria
LINAK Zweigniederlassung - Österreich (Wien)
Phone: +43 (1) 890 7446
Fax: +43 (1) 890 744615
E-mail: info@linak.de
Web: www.linak.at - www.linak.hu

Belgium
LINAK Actuator-Systems NV/SA
(Belgium & Luxembourg)
Phone: +32 (0)9 230 01 09
E-mail: beinfo@linak.be
Web: www.linak.be - www.fr.linak.be

Brazil
LINAK Do Brasil Comércio De Atuadores Ltda.
Phone: +55 (11) 2832 7070
Fax: +55 (11) 2832 7060
E-mail: info@linak.com.br
Web: www.linak.com.br

Canada
LINAK Canada Inc.
Phone: +1 502 253 5595
Fax: +1 416 255 7720
E-mail: info@linak.ca
Web: www.linak-us.com

Czech Republic
LINAK C&S s.r.o.
Phone: +42 058 174 1814
Fax: +42 058 170 2452
E-mail: info@linak.cz
Web: www.linak.cz - www.linak.sk

Denmark - International
LINAK International
Phone: +45 73 15 15 15
E-mail: info@linak.com
Web: www.linak.com

Denmark - Sales
LINAK Danmark A/S
Phone: +45 86 80 36 11
Fax: +45 86 82 90 51
E-mail: linak@linak-silkeborg.dk
Web: www.linak.dk

Finland
LINAK OY
Phone: +358 10 841 8700
E-mail: linak@linak.fi
Web: www.linak.fi

France
LINAK France E.U.R.L
Phone: +33 (0) 2 41 36 34 34
Fax: +33 (0) 2 41 36 35 00
E-mail: linak@linak.fr
Web: www.linak.fr

Germany
LINAK GmbH
Phone: +49 6043 9655 0
Fax: +49 6043 9655 60
E-mail: info@linak.de
Web: www.linak.de

India
LINAK A/S India Liaison Office
Phone: +91 120 4531797
Fax: +91 120 4786428
E-mail: info@linak.in
Web: www.linak.in

Ireland
LINAK UK Limited (Ireland)
Phone: +44 (0)121 544 2211
Fax: +44 (0)121 544 2552
+44 (0)796 855 1606 (UK Mobile)
+35 387 634 6554 (Rep.of Ireland Mobile)
E-mail: sales@linak.co.uk
Web: www.linak.co.uk

Italy
LINAK ITALIA S.r.l.
Phone: +39 02 48 46 33 66
Fax: +39 02 48 46 82 52
E-mail: info@linak.it
Web: www.linak.it

Japan
LINAK K.K.
Phone: 81-45-533-0802
Fax: 81-45-533-0803
E-mail: linak@linak.jp
Web: www.linak.jp

Malaysia
LINAK Actuators Sdn. Bhd.
Phone: +60 4 210 6500
Fax: +60 4 226 8901
E-mail: info@linak-asia.com
Web: www.linak.my

Netherlands
LINAK Actuator-Systems B.V.
Phone: +31 76 5 42 44 40 /
+31 76 200 11 10
E-mail: info@linak.nl
Web: www.linak.nl

New Zealand
LINAK New Zealand Ltd
Phone: +64 9580 2071
Fax: +64 9580 2072
E-mail: nzsales@linak.com.au
Web: www.linak.com.au

Norway
LINAK Norge AS
Phone: +47 32 82 90 90
E-mail: info@linak.no
Web: www.linak.no

Poland
LINAK Polska
LINAK Danmark A/S (Spółka Akcyjna)
Phone: +48 22 295 09 70 /
+48 22 295 09 71
E-mail: info@linak.pl
Web: www.linak.pl

Republic of Korea
LINAK Korea Ltd.
Phone: +82 2 6231 1515
Fax: +82 2 6231 1516
E-mail: info@linak.kr
Web: www.linak.kr

Slovakia
LINAK Slovakia S.R.O.
Phone: +421 51 7563 444
Web: www.linak.sk

Spain
LINAK Actuadores, S.L.u
Phone: +34 93 588 27 77
Fax: +34 93 588 27 85
E-mail: esma@linak.es
Web: www.linak.es

Sweden
LINAK Scandinavia AB
Phone: +46 8 732 20 00
Fax: +46 8 732 20 50
E-mail: info@linak.se
Web: www.linak.se

Switzerland
LINAK AG
Phone: +41 43 388 31 88
E-mail: info@linak.ch
Web: www.linak.ch - www.fr.linak.ch
www.it.linak.ch

Taiwan
LINAK (Shenzhen) Actuator systems Ltd.
Taiwan Representative office
Phone: +886 2 272 90068
Fax: +886 2 272 90096
E-mail: sales@linak.com.tw
Web: www.linak.com.tw

Turkey
LINAK İth. İhr. San. ve Tic. A.Ş.
Phone: +90 312 4726338
Fax: +90 312 4726635
E-mail: info@linak.com.tr
Web: www.linak.com.tr

United Kingdom
LINAK UK Limited
Phone: +44 (0)121 544 2211
Fax: +44 (0)121 544 2552
E-mail: sales@linak.co.uk
Web: www.linak.co.uk

DISTRIBUTORS

Argentina
Novotec Argentina SRL
Phone: 011-4303-8989 / 8900
Fax: 011-4032-0184
E-mail: info@novotecargentina.com
Web: www.novotecargentina.com

Colombia
MEM Ltda
Phone: +[57] (1) 334-7666
Fax: +[57] (1) 282-1684
E-mail: servicioalcliente@memltda.com.co
Web: www.mem.net.co

India
Mechatronics Control Equipments India Pvt Ltd
Phone: +91-44-28558484, 85
E-mail: bala@mechatronicscontrol.com
Web: www.mechatronicscontrol.com

Indonesia
PT. Himalaya Everest Jaya
Phone: +6 221 544 8956 /+6 221 544 8965
Fax: +6 221 619 1925
Fax (Sales): +6 221 619 4658
E-mail: hejplastic-div@centrin.net.id
Web: www.hej.co.id

Israel
NetivTech LTD
Phone: +972 55-2266-535
Fax: +972 2-9900-560
E-mail: info@NetivTech.com
Web: www.netivtech.com

Singapore
Servo Dynamics Pte Ltd
Phone: +65 6844 0288
Fax: +65 6844 0070
E-mail: servodynamics@servo.com.sg

South Africa
Industrial Specialised Applications CC
Phone: +27 011 466 0346
E-mail: gartht@isagroup.co.za
Web: www.isaza.co.za

United Arab Emirates
Mechatronics
Phone: +971 4 267 4311
Fax: +971 4 267 4312
E-mail: mechtron@emirates.net.ae