

Focus on
Wastewater treatment

Advantages of linear electric actuator systems

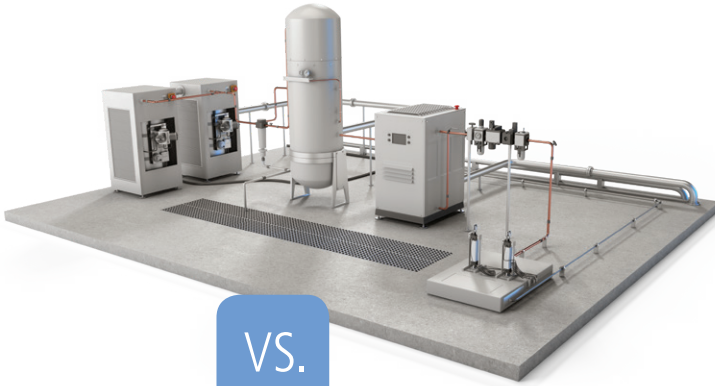

VS.

Pneumatic system

- Complex system of compressor, pumps, valves, filters, lubricators, flow controls etc.
- Difficult to control the linear position
- Requires routine maintenance
- High energy consumption



VS.

Rotary actuator/gear

- Heavy and bulky
- Requires routine maintenance
- Installation and replacement is done using a crane



Electric actuator system

- Simple system of actuator, control and power connection
- Maintenance-free
- Low energy consumption
- Lightweight
- DIY installation

Reliable and optimised solutions for wastewater treatment

In the wastewater industry easy control and monitoring are key elements for ensuring optimal day-to-day running of wastewater treatment facilities. LINAK® actuators provide easy to monitor automation for a wide range of applications within this industry, which ensures a reliable operation in the facility in that the operator knows if the valves are running optimally according to their position.

An electric movement solution from LINAK is easy and simple to install and can be used for several different types of valves, e.g. slide gate, sluice gate/penstock, gate and knife gate valves that are mounted in wells and around the wastewater facilities. Also, when using a LINAK actuator solution high service costs are avoided because the actuators are maintenance-free. With a LINAK actuator it is possible to control valves over long distances using an internal communication and feedback system. The system can also connect with SCADA. This ensures that the valves can open and close variably, leading the wastewater in the right direction. Furthermore, if the control system is down, it is possible to operate the actuator manually.

A LINAK system has many advantages:

- Easy to install and to operate (by means of hand controls, remote controls or switches)
- Compatible with various PLC systems – no need for extra backup
- Maintenance free
- Built-in feedback
- Low operating costs
- Low standby power consumption
- Robust and reliable solution well-suited for operation in very harsh environments (IP69K)
- Offers a good price/performance ratio compared to pneumatics
- An environmentally friendly solution
- A complete movement solution
- High self-locking ability, also when the actuator is turned off
- Precise position feedback and accurate variable control over acceleration and velocity

LINAK as your partner

We do not want to be merely another supplier to our customers. We want to be your partner.

It is important to us that your wastewater applications work relentlessly and we know that many applications often require 100% uptime - because any failure can lead to harmful or costly disruptions. All our actuators have gone through extensive testing so you can rest assured that your TECHLINE® actuator solutions will do the job no matter what.

Furthermore, all members of the TECHLINE team of engineers and consultants have vast product and application expertise.

So, when partnering with LINAK you get more than just a product in your hands. It is our goal to create added value to our customers by offering innovative solutions, extensive knowledge, world-class production and global presence.

LINAK offers service
worldwide

Please contact your local LINAK office with
your enquiry



What LINAK actuators do for wastewater treatment applications

Electric actuator solutions from LINAK® provide precise and smooth motion control for wastewater treatment plants. For industry valves (slide-, sluice-, gate- and knife gate valves) used on sludge heat exchangers, decanter centrifuges, sand washers, aeration tank blowers and tilting weirs, LINAK actuators improve automation performance.

The actuator systems offer simple installation with few components and an easy 'all in one package' solution.

Furthermore, their multiple and advanced feedback options ensure a reliable and high level of performance.

All these advantages combined provide cost-efficient automation for wastewater treatment facilities.





TRLU191142 0
US4532

TRLU191142 0

LINAK systems for valves and gates

LINAK® knows the market and the demands that utility companies and valve producers have for movement solutions for valves.

For many years LINAK has been a supplier of electric movement solutions for industries requiring solutions that are able to work relentlessly in extremely harsh environments.

This is why our products are well suited as valve actuators which are often mounted in demanding environments.

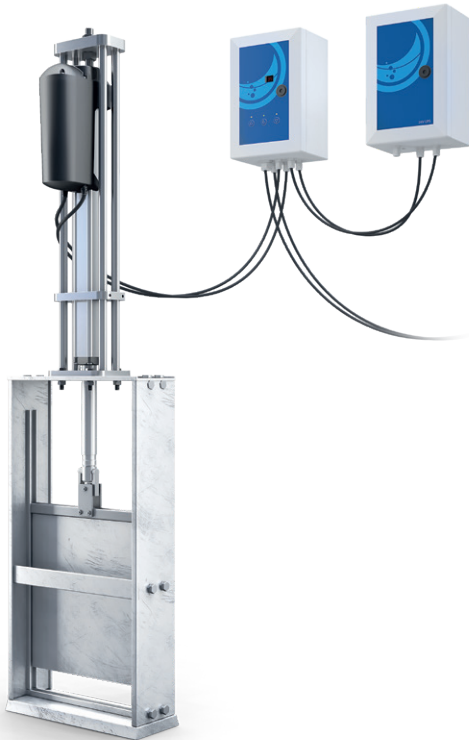

Sluice gate

A LINAK solution for sluice gates can be controlled over long distances due to its built-in communications and feedback system. The solution ensures that the sluice gate can open and close variably.



Knife gate valve

The knife gate valve can be mounted on various wastewater handling applications. LINAK has taken an innovative approach to the control of the actuator by designing an external control box which is easy to access - no matter how and where the actuator and valve are installed.



The Water Valve Control Unit (WCU) ensures a reliable connection to the wastewater treatment plant's SCADA system, making remote control of the actuator easy.

The battery backup is an optional add-on ensuring a fail-safe operation in case of power cut-offs.



What LINAK actuators do for hatches and weirs

One of the advantages of using a LINAK® actuator for the tilting weir is the simple installation of the electric system, which can be fitted to an already existing tilting weir solution without having to make a completely new solution design.

It is also easy to change the position settings on the actuator to ensure a correct flow of water from the tilting weir. Furthermore, with this maintenance-free and easily adjustable actuator solution service is not necessary, and position adjustments can be made by the wastewater facility's own technician.

Hatches are seen on several wastewater applications for instance disc fillers, drum fillers and decanter centrifuge. With LINAK actuators it is possible to have a simple one-patch-solution that can lift a large hatch in parallel.

This will create greater accessibility to for instance the disc filters, providing easier service and increased operational efficiency.

Service is also made easier with the internal feedback of LINAK actuators, that allows the user to make different position settings for the system. E.g. the hood covering the disc filters can be set to a position for regular maintenance of the filters, and a position for when the filters need to be changed.

Hatch

Opening and closing the hatch for easy access to the disc filters



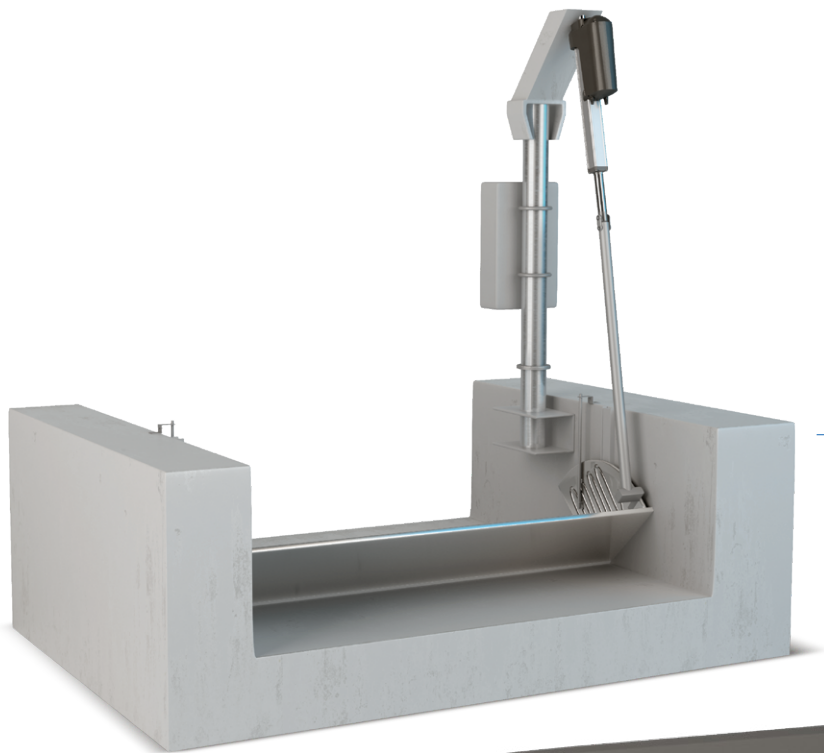

Tilting weir

Adjusting the tilting weir to ensure a correct flow of water



Hatch

Raising and lowering the hatch of the decanter centrifuge

What LINAK actuators do for clarifier cleaning

For the clarifier LINAK® actuator systems offer a maintenance-free 'all in one package' solution that is simple to install and operate. With its small built-in dimensions the actuator can easily be fitted to the top of the brush for the purpose of raising and lowering the brush for de-icing or cleaning the surface of the basin edge. Using temperature sensors together with the actuator will ensure a very reliable automation without the need for manual adjustment or external control. Furthermore, the feedback system of the actuator makes it possible to always read out the position of the brush.

Brush

Raising and lowering the cleaning and de-icing brush

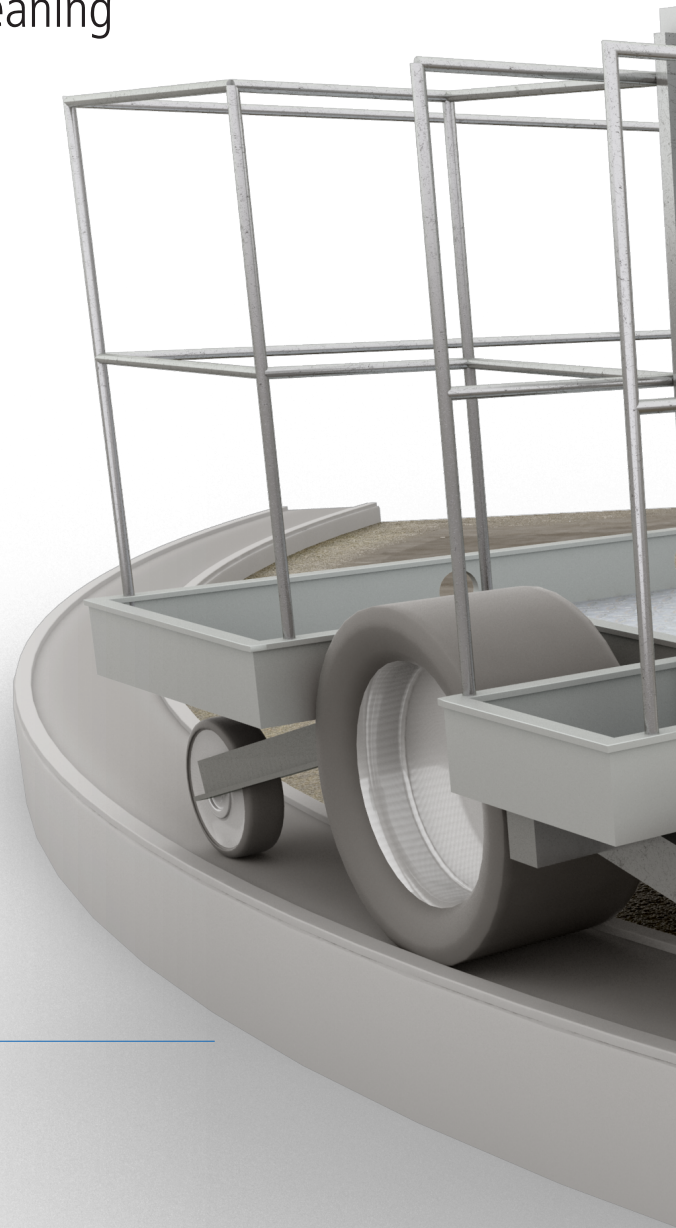



Explore the rich technology behind actuators



At the Actuator Academy™, you will find a library of videos and information about actuator components, actuator testing, and intelligent actuator control.

Find out what you should expect of a good industrial actuator, what affects its performance and efficiency, and how to best utilise your linear motion actuator.

We hope to inspire you and ultimately make you wiser on the moving electric revolution we are all part of.

Happy exploring!

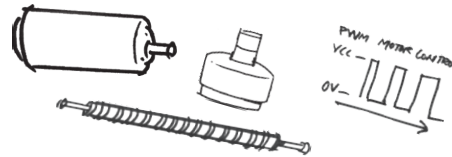
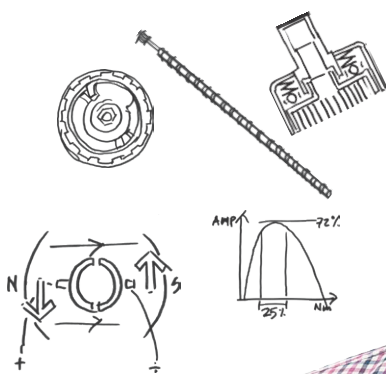

Check out the
Actuator Academy

**LINAK.COM/
ACTUATOR-ACADEMY**

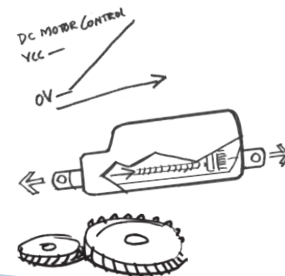

Smart movement for wastewater treatment

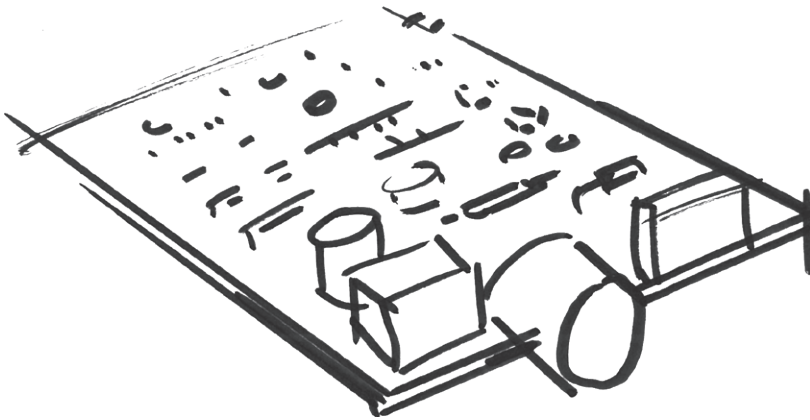

A LINAK® IC actuator with built-in controller reduces the number of external components and the need for a third-party supplier for power electronics.

It also offers a comprehensive range of interfaces and gives you access to productivity enhancing data - all delivered by a single supplier you can trust.

By helping you move smarter at every stage of your application process, from development, installation and integration to tailored movement and improved productivity, our IC actuators add value across the board.

IC INTEGRATED CONTROLLER™

Choosing an IC actuator for your application is a smart move in many ways:

- Reduced complexity for faster development and production
- Flexible integration with a variety of industrial interfaces
- Data monitoring that minimise downtime and boost productivity
- Benefit from one single supplier



For more information on IC, please visit LINAK.COM or scan the QR code.

Actuators for wastewater treatment

LINAK® industrial actuators offer a versatile array of movement solutions for wastewater treatment.

With **thrusts up to 15,000 N, max speeds up to 160 mm/s, and strokes between 20 and 999 mm**, the actuators are highly adaptable for a wide variety of applications.

Industrial actuators with **heavy-duty aluminium housings** are very suitable for use in corrosive environments. Having been thoroughly **salt spray and chemical resistance** tested and approved for ratings up to IP66 and IP69K static, these actuators will work reliably for years, even when exposed to salt, water, wind, and sun.

Operating temperatures between -40°C to +85°C make them fit for work in numerous settings.

Actuator LA36



Actuator LA33



Actuator LA25



Accessories

Flange Mounting Bracket

The Flange Mounting Bracket serves an easy flange mounting of LINAK® electric actuators on industrial valves typically used in wastewater treatment facilities. The bracket interface dimensions are in accordance with the industry standards ISO 5210 and ISO 5211, and it fits with the flange types F07 and F10.

Features:

- Flange mounting possibilities
- Surface treatment: Stainless steel
- Compatible with: LA36, LA37

Facts:

- Bracket for flange mounting of actuators
- In accordance with ISO 5210 and ISO 5211
- Flanges F07 and F10

Scope of application:

- Valves



Accessories and controls

Water valve control unit

WCU-Basic: Analogue/Digital

WCU-BUS: Profibus

Features for WCU-Basic:

- Endstop signals
- Controlled with an analogue 4-20 mA signal or digital on/off signal
- 4-20 mA feedback signal
- Can be remotely or manually controlled
- Ready signal for auto mode
- Signal for overcurrent and manual operation
- Display showing actual valve position (0-100%)
(*)

Features for WCU-BUS:

- Available with Profibus as a standard or as an add-on

Battery back-up

WCU-UPS

Features for WCU-UPS:

- 24V DC power supply
- Automatic charge and control of battery level
- Fail safe positioning
- Output: 5 A continuous
12 A for 5 min.
15 A for 10 sec.
(*)



(*) "The specified product is a third party product that is produced by third party and distributed by LINAK as a supplement to the existing LINAK product range. It is the responsibility of the product user to determine the suitability of the product for a specific application. LINAK will at point of delivery replace/repair defective products covered by the warranty if promptly returned to LINAK."



QUALITY

Built by market leading experts, using state-of-the-art technologies and perfected production methods, you can expect the same quality worldwide.



INNOVATION

Innovation is in our core. We take the lead and have the courage to make it real.



RESPONSIBILITY

We are responsible in what we do – towards customers, employees and environment. Creating trust is a natural part of who we are.



**LOCAL
& GLOBAL**

From global presence to local understanding. We believe in world-wide support and being close to our customers.

Testing programme

In each industrial application, the actuator is just one component of many, but at LINAK® we fully appreciate that it is of utmost importance to you and your customers. Not a single actuator leaves the factory until it has undergone a 100% function test.

Depending on the actuator type, various tests have been carried through. Please consult your local LINAK office or take a look at the actuator data sheet in question to get a thorough test overview.

This is your guarantee that a solution based on LINAK TECHLINE electric actuator systems is a solution that will work reliably for years and years.

“Our actuators must never malfunction. Therefore, it is important that all our products are tested inside and out, and to the extreme in a wide range of tests.”

- Claus H. Sørensen, Director R&D

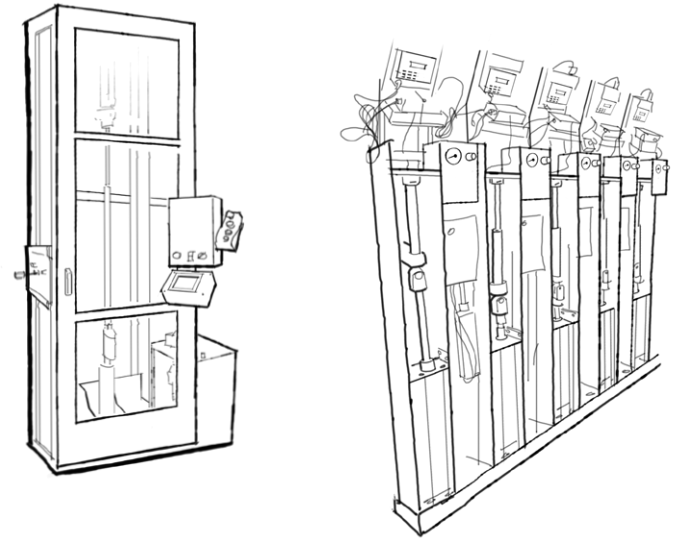

Climatic tests:

In the climatic test the actuators are tested to operate in extreme temperatures as well as to endure rapid changes in temperature. In a dunk test, the actuators have to withstand repeating temperature fluctuations between +85°C to -40°C and still maintain full functionality and ingress protection.

EN60529-IP6X	- Dust
EN60529-IPX6	- Water
ISO16750- IP69K	- High pressure cleaning
IEC60068-2-3	- Moisture storage
IEC60068-2-30	- Operation in moisture
ISO16750-4:2010	- Dunk test
EN60068-2-52	- Salt spray
BS7691 Section 6.11.2.4	- Chemicals

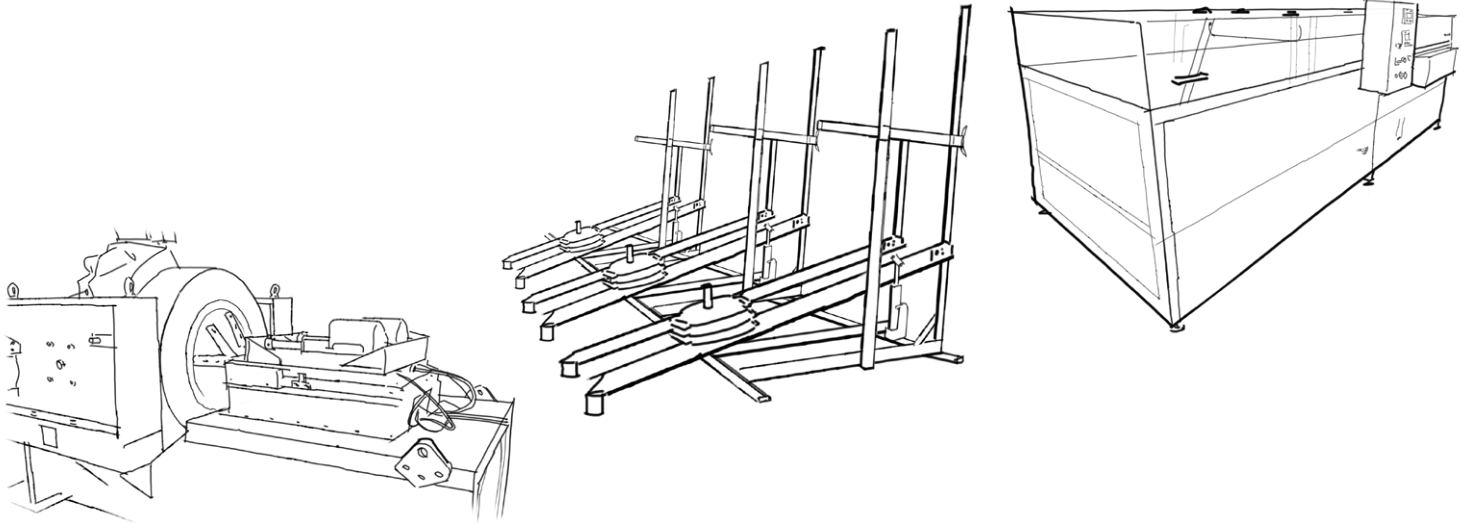

Electrical tests:

All electrical parts are tested i.e. power supply, power and signals cables, control signals etc. Electrical immunity is tested according to industrial standards i.e. for radio noise, electrical discharge and burst.*

EN/IEC 61000-6-4	- Generic standard emission industry
EN/IEC 60204	- Electrical equipment of machinery
EN 50121-3-2	- Railway applications - Rolling stock apparatus
94/25/EC	- Recreational crafts directive
EN/ISO 13766	- Earth moving machinery
EN/IEC 61000-6-2	- Generic standard immunity industry
2004/104/EC	- Automotive Directive
EN/ISO 14982	- Agricultural and forestry machines
EN/ISO 13309	- Construction machinery

* These tests do not apply to third party products!

Mechanical tests:

Vibration: The actuator must withstand continuous vibration in three directions.

Shock: The shock test puts the actuator through 3 shocks of up to 50 G in each of six directions.

Bump: The actuator receives bumps of up to 30 G in each of six directions several hundred times.

EN60068-2-64 (Fh) - Random vibration

EN60068-2-27 (Ea) - Shock

EN60068-2-29 (Eb) - Bump

Find out more about how we test actuators to the extreme:

linak.com/segments/techline/tech-trends/testing/





For further information, please visit our website:
[LINAK.COM/BUSINESS-AREAS/VALVES/WASTEWATER-HANDLING/](https://www.linak.com/BUSINESS-AREAS/VALVES/WASTEWATER-HANDLING/)

LINAK® accepts no responsibility for possible errors or inaccuracies in catalogues, brochures, and other material. LINAK reserves the right to change its products without prior notice. LINAK cannot guarantee product availability and reserves the right to discontinue the sale of any product. User is responsible for determining the suitability of LINAK products for a specific application. All sales are subject to the 'Standard Terms of Sale and Delivery', available on LINAK websites.

LINAK and the LINAK logotype are registered trademarks of LINAK A/S. All rights reserved.



QUALITY

Built by market leading experts, using state-of-the-art technologies and perfected production methods, you can expect the same quality worldwide.



INNOVATION

Innovation is in our core. We take the lead and have the courage to make it real.



RESPONSIBILITY

We are responsible in what we do – towards customers, employees and environment. Creating trust is a natural part of who we are.



**LOCAL
& GLOBAL**

From global presence to local understanding. We believe in world-wide support and being close to our customers.