

Accessories

User Manual

Contents

Preface	4
GENERAL ASSEMBLY INSTRUCTIONS	5
DECLARATION OF INCORPORATION OF PARTLY COMPLETED MACHINERY	6
Important information	7
General warnings	8
General recommendations	11
General Regulatory Considerations	12
General warranty periods	12
Electromagnetic Compatibility (EMC)	13
EMC Warnings	13
EMC responsibilities for LINAK actuator systems	14
Electrostatic discharge (ESD)	15
RF transmitter/receiver properties.....	16
FCC and IC Statements.....	16
Symbols	17
Batteries	19
General battery warnings	19
Lithium ion batteries	20
Lead acid batteries	23
System description	24
Connecting the system	24
General mounting of accessories	25
General environmental conditions	26
Information on start-up, deinstallation and operation	27
Before installation, deinstallation or troubleshooting	27
Before start-up	27
During operation	27
Cleaning	28
Cleaning warnings.....	28
IPX6 Washable	29
Rinsing aids	30
IPX6 Washable DURA™	31
Cable wash	32
General maintenance	33
Maintenance of all LINAK accessories	33
Repair and disposal	34
Insulation class	35
Output ratings	35
Troubleshooting	36

BA15	37
BA16	42
BA18	45
BA22 Li-Ion	47
DIN Junction Box (DJB)	51
Massage Motor	52
Modular Junction Box - MJB2	53
Modular Junction Box - MJB5 Plus Port Repeater	54
Modular Junction Box - MJB5 Plus Port SMPS	61
Modular Junction Box - MJB5 Plus Gateway	70
Modular Junction Box - MJB5 Plus UBL (int.)	81
Modular Junction Box - MJB5 Plus Switch Input	91
Modular Junction Box - MJB5 Plus AOC	101
Power Junction Box - PJB4	111
QLCI2	116
Simulator Tool	126
Safety/Signal Limit Switch (SLS)	128
Switch Mode Power Supply - SMPS10	130
Switch Mode Power Supply - SMPS10 Floor	131
Under Bed Light (UBL)	132
Under Bed Light (UBL) 2	133
Under Bed Light (UBL) 4 Motion	134
USB-A Power Adapter	136
Contacts	139

Preface

Dear User,

We are delighted that you have chosen a LINAK® product.

LINAK systems are high-tech products based on many years of experience in the manufacture and development of actuators, lifting columns, desk frames, electric control boxes, controls, batteries, accessories and chargers.

This User Manual does not address the end user. It is intended as a source of information for the equipment or system manufacturer only, and it will tell you how to install, use and maintain your LINAK product/system. The manufacturer of the end product has the responsibility to provide a User Manual where relevant safety information from this manual is passed on to the end user.

We are convinced that your LINAK system will give you many years of problem-free operation.

Before our products leave the factory they undergo full function and quality testing. Should you, nevertheless, experience problems with your product/system, you are always welcome to contact your local supplier.

LINAK subsidiaries and some distributors situated all over the world have authorised service centres, which are always ready to help you.

LINAK provides a warranty on all products (see warranty section).

This warranty, however, is subject to correct use in accordance with the specifications, maintenance being done correctly and any repairs being carried out at a service centre, which is authorised to repair LINAK products.

Changes in installation and use of LINAK systems can affect their operation and durability. The products are only to be opened by authorised personnel.

This User Manual has been written on the basis of the present technical knowledge. LINAK is constantly keeping the information updated and we therefore reserve the right to carry out technical modifications.

The introductory pages of this manual may contain information that is not applicable to the technical product pages and are to be seen as general information for all LINAK products.

LINAK A/S



GENERAL ASSEMBLY INSTRUCTIONS

Please read the following safety information carefully. Ensure that all staff who are to connect, mount, or use the actuator are in possession of the necessary information and that they have access to this assembly instruction.

Persons who do not have the necessary experience or knowledge of the product/products must not use the product/products. Besides, persons with reduced physical or mental abilities must not use the product/products, unless they are under surveillance or they have been thoroughly instructed in the use of the apparatus by a person who is responsible for the safety of these persons. Moreover, children must be under surveillance to ensure that they do not play with the product.



Warnings

Failure to comply with these instructions may result in accidents involving serious personal injury.

It is important for everyone who is to connect, install, or use the systems to have the necessary information and access to the User Manual on www.linak.com.

- If there is visible damage on the product it must not be installed.
- If the control box / Twindrive makes unusual noises or smells, switch off the mains voltage immediately.
- The products must only be used in an environment that corresponds to their IP protection.
- The cleaners and disinfectants must not be highly alkaline or acidic (pH value must be 6 to 8).
- Irrespective of the load, the duty cycle stated in the data sheets, must NOT be exceeded.
- The DESKLINE® systems can only be used in push applications.
- The control box / Twindrive must only be connected to the voltage stated on the label.
- System not specified for pull must only be used in push applications.
- Fastening screws and bolts must be tightened correctly.
- Do not open the closing device on the Twindrive during operation.
- Specifications on the label must under no circumstances be exceeded.
- NOT TO BE OPENED BY UNAUTHORIZED PERSONNEL.
- Use only the actuator within specified working limits.
- Note that during construction of applications, in which the actuator is to be fitted, there must be no risk of personal injury, such as squeezing of fingers or arms.
- If irregularities are observed, the actuator must be replaced.
- If the actuator is used for pull in an application where personal injury can occur, the following is valid: It is the application manufacturer's responsibility to incorporate a suitable safety arrangement, which will prevent personal injury from occurring, if the actuator should fail.
- MEDLINE® & CARELINE® products are rated to operate at an altitude < 2000 m.



Recommendations

Failure to follow these instructions can result in the actuator being damaged or being destroyed.

- Before you start mounting/dismounting, ensure that the following points are observed:
 - The actuator is not in operation.
 - The mains current supply is switched off and the plug has been pulled out.
 - The actuator is free from loads that could be released during this work.
- Before you put the actuator into operation, check the following:
 - The actuator is mounted correctly as indicated in the relevant user instructions.
 - The equipment can be freely moved over the actuator's whole working area.
 - The actuator is connected to a mains electricity supply/transformer with the correct voltage and which is dimensioned and adapted to the actuator in question.
 - Ensure that the voltage applied matches the voltage specified on the actuator label.
 - Ensure that the connection bolts can withstand the wear.
 - Ensure that the connection bolts are secured safely.
- During operation
 - Listen for unusual sounds and watch out for uneven running. Stop the actuator immediately if anything unusual is observed.
 - Do not side load the actuator.
 - Use only the actuator within the specified working limits.
 - Do not kick or step on the actuator.
- When the equipment is not in use
 - Switch off the mains supply or pull out the plug in order to prevent unintentional operation.
 - Check regularly the actuator and joints for extraordinary wear.
- Note: If the actuator is operated as a hand crank, it must be operated by hand, otherwise there is a risk of overloading the actuator and hereby damage the actuator.
When changing the cables on a LINAK actuator, it is important that this is done carefully, in order to protect the plugs and pins.
Please ensure that the plug is in the right location and fully pressed in before mounting the cable lid.

LINAK® 

WE IMPROVE YOUR LIFE



DECLARATION OF INCORPORATION OF PARTLY COMPLETED MACHINERY

LINAK A/S
Smedevænget 8
DK - 6430 Nordborg

LINAK A/S hereby declares that LINAK DESKLINE® products, characterised by the following models and types:

Control Boxes	CBD6S
Linear Actuators	DB5, DB6, DB14, LA23, LA31
Lifting Columns	DL1A, DL2, DL4S, DL5, DL6, DL8, DL9, DL10, DL11, DL12, DL14, DL15, DL16, DL17, DL18, DL19, DL20, DL21, BASE1, LC1
Desk Panels	DPA, DPB, DPH, DPF, DPG, DPT, DP1CS, DPI
Wireless Controls	BP10
Frames and Feet	Kick & Click, DF2, DF3, DF4, DF5, DLF
Accessories	BA001, BLE2LIN, CHUSB, DESK Sensor, SLS, SMPS, USB2LIN, WiFi2LIN, DC Connector, RFRL

LINAK A/S hereby declares that LINAK HOMELINE® products, characterised by the following models and types:

Control Boxes	CBD6DC
Linear Actuators	LA10, LA18, LA40 HOMELINE, BASE1
Dual Actuators	TD4, TD5
Controls	BP10, HC10, HC20, HC40, HC50, HC60
Accessories	BA002, CP, BLE2DC, BLE2LIN, LED Light Rail, MD1, SMPS, WiFi2LIN

LINAK A/S hereby declares that LINAK MEDLINE® & CARELINE® products, characterised by the following models and types:

Control Boxes	CA10, CA20, CA30, CA40, CA63, CAL40, CB6, CB6S, CB6P2, CB8, CB9, CBJ2, CBJ Care, CBJ Home, CO41, CO53, CO61, CO65, CO71, COL50, OPS, PJ2
Linear Actuators	KA19, KA30, KA30 ICA, LA20, LA23, LA24, LA24 ICA, LA27, LA28, LA29, LA30, LA31, LA34, LA40, LA42, LA44
Lifting Columns	BL1, LC1, LC3
Controls	ABL, ACC, ACK, ACO, ACOD, ACOM, ACL, DP, DPH, FS, FS3, FPP, HB30, HB70, HB80, HB100, HB190, HB200, HB400, HD80, HL70, HL400, SC01
Accessories	BA15, BA16, BA18, BA19, BA22, BAJ, BAJL, BAL40, BAL50, CH01, CHJ2, CHL40, CHL50, DJB, LIN2OB, MJB2, MJB5 Plus, Massage Motor, PJB4, QLC12, SLS, SMPS10, UBL, UBL2, UBL4 Motion, USB-A Power Adapter

LINAK A/S hereby declares that LINAK TECHLINE® products, characterised by the following models and types:

Linear Actuators	LA12, LA14, LA21, LA23, LA25, LA30, LA33, LA35, LA36, LA37, LA73, LA76, LA77
Lifting Columns	LC3 IC
Accessories	FMB

comply with the following parts of the Machinery Directive 2006/42/EC, ANNEX I, Essential health and safety requirements relating to the design and construction of machinery: 1.5.1 Electricity supply

The relevant technical documentation is compiled in accordance with part B of Annex VII and this documentation or part hereof will be transmitted by post or electronically to a reasoned request by the national authorities.

This partly completed machinery must not be put into service until the final machinery into which it is to be incorporated has been declared in conformity with the provisions of the Machinery Directive 2006/42/EC where appropriate.

Nordborg, 2026-05-18

John Kling

LINAK A/S

John Kling, B.Sc.E.E., Certification and Regulatory Affairs
Authorised to compile the relevant technical documentation

Original declaration

LINAK® 
WE IMPROVE YOUR LIFE



Important information

LINAK® products, within the scope of this manual, are not classified as medical electrical equipment or systems, nor do they fall within the scope of the EU Medical Device Directive/Regulation or other similar national regulations. The products are components to be built into a piece of medical electrical equipment by a manufacturer.

To support the assessment and certification task of the complete medical electrical equipment or system worldwide, LINAK provides certification, on a component level, according to the IEC 60601-1, (Medical electrical equipment – Part 1: General requirements for basic safety and essential performance) as recognised components by NRTL (Nationally Recognized Testing Laboratories).

Description of the various signs used in this manual:



Warnings

Failure to comply with these instructions may result in accidents involving serious personal injury.



Recommendations

Failing to follow these instructions can result in product damage.

Please read the following safety information carefully:

Ensure that all staff who are to connect, mount, or use the actuator system are in possession of the necessary information and that they have access to these assembly instructions.

Persons who do not have the necessary experience or knowledge of LINAK products should not use these. Moreover, persons with reduced physical or mental abilities must not use the products, unless they are under surveillance or they have been thoroughly instructed in the use of the equipment by a person who is responsible for the safety of these persons. Moreover, children must be under surveillance to ensure that they do not play with the product.

Please be aware that LINAK has taken precautions to ensure the safety of the actuator system. The manufacturer/OEM is responsible for the overall approval of the complete application.



LINAK recommends to use the actuators in push applications rather than pull applications.



LINAK actuators are not to be used for repeated dynamic push-to-pull movements.

For general pull applications or repeated dynamic push-to-pull movements in the application, please contact LINAK A/S if in doubt.

LINAK actuators and electronics generally fall outside the IEC 60601-1 definition of applied parts and are not marked as such.

However, assessing the risk whether actuators and electronics can unintentionally come into contact with the patient, determines that they are subject to the requirements for applied parts. All the relevant requirements and tests of the standard are carried out as part of the IEC CB* Scheme/NRTL** assessment.













* CB: Certification Body













**NRTL: Nationally Recognised Testing Laboratory



General warnings

Failure to comply with these instructions may result in accidents involving serious personal injury:

-  The medical device manufacturer is responsible for the incorporation of a suitable safety arrangement, if the actuator or lifting column is used for pull in an application where personal injury can occur, which will prevent personal injury from occurring in case of actuator failure.
-  Note that during construction of applications, in which the actuator is to be fitted, there must be no possibility of personal injury, for example the squeezing of fingers or arms.
-  The plastic parts in the system cannot tolerate cutting oil.
-  Assure free space for movement of the application in both directions to avoid a blockade.
-  The application and actuators are only to be operated by instructed personnel.
-  In applications with spline function, the blockage by an obstacle when the application is moving inwards, the removal of the obstacle will cause the load to drop until the spindle hits the nut.
-  Do not turn the outer tube.
-  Do not use chemicals.
-  Inspect the actuator system regularly for damage and wear.
-  Do not expose LINAK actuator system components to high intensity ultraviolet radiation disinfection lamps. This may damage the enclosure, supporting parts and cables.
-  LINAK actuators and electronics are not designed for use within the following fields:
 - In the presence of a flammable anesthetic mixture with air or with oxygen or nitrous oxide
 - Planes and other aircrafts
 - Explosive environments
 - Nuclear power generation
-  If faults are observed, the products must be replaced.

-  A LINAK control box, actuator and accessory component must, in the final application, be placed where it is not exposed to any impact. This is to prevent damage if a passer-by accidentally hits it with an object or when cleaning the floor with a broom or a mop. On a medical bed e.g. this might be underneath the mattress support platform. If necessary to mitigate this risk, additional protection might be required.
-  To avoid unintended movement, prevent foreign objects or persons from unintentionally activating a footswitch or a hand control at any time, for instance during normal use or maintenance.
-  If there is visible damage on the product it should not be installed.
-  If the actuator system makes unusual noise or smells, switch off the mains voltage immediately and disconnect batteries, if applicable.
-  The products must only be used in an environment that corresponds to their IP protection class.
-  The cleaners and disinfectants must not be highly alkaline or acidic (pH value 6-8). See cleaning section.
-  Irrespectively of the load, the duty cycle stated on the product label must NOT be exceeded.
-  The control box must only be connected to the voltage stated on the label.
-  Systems not specified for pull must only be used in push applications.
-  Fastening screws and bolts must be tightened correctly.
-  Specifications on the product label must under no circumstances be exceeded.
-  NOT TO BE OPENED BY UNAUTHORISED PERSONS.
-  Only use the actuator within specified working limits.



Be aware that during the design of medical devices, the risk of personal injury (for instance squeezing of fingers or arms) must be minimised.



If irregularities are observed, the actuator must be replaced.



All cables must be mounted in such a way that they are not trapped or exposed to tension or sharp objects when the application is moved in different directions.



General recommendations

Failing to follow these instructions may result in actuator system damage:



The duty cycle printed on the actuator system label must always be respected. If exceeded, there is a risk that the actuator system is damaged. Unless otherwise specified on the label, the duty cycle is max. 10%, max. 2 min. in use followed by 18 min. not in use.



All detachable connections between components must be locked by the cable locking mechanism - when applicable.



It is recommended to have options like quick release, manual lowering or similar built into the system in case of power loss or system failure or if movement of the system is critical. After service it is recommended to test the system for correct functionality before it is put back into operation.



Prior to assembly/disassembly, ensure that the following points are observed:

- The actuator system is not in operation.
- The mains current supply is switched off and the plug has been pulled out.
- Batteries - if applicable - may also power the system.
- Actuators are free from loads that could be released during this work.



Prior to operating the actuator system, check the following:

- Actuator system components are correctly mounted as indicated in the product-specific user instructions.
- The equipment can be operated in its entire intended range of movement.
- Ensure that the load-supporting bolts can withstand the wear.
- Ensure that the load-supporting bolts are secured safely.



During operation:

- Listen for unusual sounds and watch out for uneven movement. Stop the actuator system immediately if anything unusual is observed.
- Do not sideload the actuator.
- Do not step on or kick any LINAK component.



When the equipment is not in use:

- Switch off the mains supply or pull out the plug in order to prevent unintentional operation.



Cables and plugs:

- It is important to remove the transport plastic bag before using the cable.
- When changing the cables on a LINAK® actuator system, it is important that this is done carefully in order to protect the plugs and pins.
- Please ensure that the plug is in the right location and properly inserted before the cable lid is mounted.



General Regulatory Considerations

Certain LINAK components are not individually certified under IEC 60601-1 due to incomplete constructional features that prevent full compliance. Specifically, products without enclosures, such as for instance those exposing printed circuit boards or mechanical parts, do not meet the safety requirements outlined in the standard.

Medical equipment must comply with strict regulations to ensure the safety of patients and healthcare professionals.

When LINAK components are integrated into a medical device, it is the responsibility of the medical device manufacturer to ensure that these components are adequately enclosed.

Ultimately, the medical device manufacturer is responsible for ensuring that the final product complies fully with IEC 60601-1 and all other applicable standards.

General warranty periods

As general warranty period, LINAK provides 5 years (60 months) warranty on MEDLINE and CARELINE products used in beds and medical applications. If MEDLINE and CARELINE products are used in other applications, they will be covered by 1½ years (18 months) warranty.

Batteries are covered by a specific product warranty of 12 months.

External products that are not manufactured by LINAK A/S: 12 months are added to the warranty period, for instance for transportation and stocking. Relabelling of these products only takes place, if the production date exceeds one year from the date of dispatch to the customer.

If there is any doubt whether returned products are covered by the warranty, they are covered by the warranty. Please use the date of the control box or actuator as reference, if possible.



Electromagnetic Compatibility (EMC)

EMC Warnings



Electromagnetic compatibility – general

LINAK® actuator systems bear the CE marking as an attestation of compliance with the EMC Directive 2014/30/EU. The systems are designed to meet all requirements of applicable standards and have been tested to meet IEC 60601-1-2 requirements.

Emission:

LINAK Actuator Systems are CISPR 11, Group 1, Class B products, comply with IEC 61000-3-2, Class A and IEC 61000-3-3.

Immunity:

Test levels are according to Professional Healthcare Facility and Home Healthcare Facility Environment.

Electromagnetic phenomena are evaluated on a system level, with the actuator connected to a LINAK control box and accessories.

LINAK always recommends to perform verification tests on the final medical device.



Electromagnetic compatibility – third party components

Use of accessories, transducers and cables other than those specified by LINAK could result in increased electromagnetic emissions or decreased electromagnetic immunity of the actuator system and result in improper operation.



Electromagnetic compatibility – interference with other equipment in general

Use of the actuator system adjacent to or stacked with other equipment should be avoided as this could result in improper operation. If such use is necessary, the actuator system and the other equipment should be observed to verify that they are operating properly.

If the user notes unusual behavior of the actuator system, in particular if such behaviour is intermittent and associated with the standing right next to mobile phones, microwaves and radio broadcast masts, this could be an indication of electromagnetic interference.

If such behaviour occurs, try to move the actuator system further away from the interfering equipment.



Electromagnetic compatibility – interference with other equipment, RF communications

RF communication equipment (e.g. RFID, wireless RF etc. including peripherals such as antenna cables and external antennas) should be used at a distance no closer than 30 cm (12 inches) to any part of the actuator system. This also applies to cables specified by the manufacturer. Otherwise, a performance degradation of this equipment could result.



EMC responsibilities for LINAK actuator systems

LINAK verifies the EMC performance of each LINAK product and approves them individually. The LINAK products can be combined and integrated into many different systems. LINAK also verifies the system EMC performance on commonly used combinations.

LINAK has certificates in accordance with applicable standards for each product and provides the customers, who are building the application and integrating these products into systems (systems with control box, actuators, cables, batteries, etc.), with these certificates.

However, EMC testing of LINAK products in generic LINAK systems is not made in an environment that corresponds to the specific application environment which differs from the generic testing environment. There will be differences that can affect the EMC performance in the specific target application.

The customer is responsible for qualifying and approving the complete application including the LINAK system.

Regulatory standard

LINAK products, being components to be incorporated by a Manufacturer [definition: IEC 60601-1 ed.3.1, cl. 3.55] into Medical Electrical Equipment [definition: IEC 60601-1 ed.3.1, cl. 3.63], are tested concerning the EMC phenomena according to the Collateral Standard IEC 60601-1-2 ed. 4.1.

IEC 60601-1-2 ed. 4.1 sets forth the requirements for the electromagnetic compatibility of Medical Electrical Equipment, ensuring that devices operate safely and effectively within their intended environments. Compliance with this standard is essential to minimize electromagnetic interference and maintain the integrity and performance of Medical Devices.

Furthermore, IEC 60601- 1-2 ed. 4.1 states:

“This collateral standard recognizes that the Manufacturer has the responsibility to design and perform Verification of Medical Electrical Equipment and Medical Electrical Systems to meet the requirements of this Collateral Standard and to disclose information to the Responsible Organization or Operator so that the Medical Electrical System will remain safe throughout its Expected Service Life.”

Qualification process of a new application

The qualification process for a new application is normally done in cooperation between the customer and LINAK. LINAK provides the relevant support, competence and documentation needed for the customer's overall development plan and test plan for the specific application.

The driver of the qualification process is the customer who has the ultimate application responsibility (MDS). The customer identifies and specifies the needed testing based on many different parameters (experience, risk management, requirements from standards, etc.).

In many cases, the customer is establishing and verifying tests early in the project to ensure that the approval process has a low risk of failing when tested in the approval institute.

The customer identifies which tests to make and when they are to be performed in the project to mitigate the risk of failure in the approval process which also includes EMC testing.



Electrostatic discharge (ESD)

LINAK® considers ESD to be an important issue and years of experience have shown that equipment designed to meet the levels specified in standards might be insufficient to protect electronic equipment in certain environments.

1. Handling and mounting electrostatic discharge sensitive devices (ESDS devices).

- Handling of sensitive components shall only take place in an ESD Protected Area (EPA) under protected and controlled conditions.
- Wrist straps and/or conductive footwear (personal grounding) shall always be used when handling ESDS devices.
- Sensitive devices shall be protected outside the EPA by the use of ESD protective packaging.

2. Responsibility LINAK/customer

- ESDS devices must under no circumstances, during transport, storage, handling, production or mounting in an application, be exposed to harmful ESD.
- LINAK can only guarantee the lifetime of ESDS devices if they are handled in the same way from production at LINAK A/S until they are mounted in the manufacturer's application. It is therefore important that the ESDS devices are not removed from the ESD protected packaging before they are physically within the EPA area at the customer premises.

Please refer to EN61340 for further information:

EN61340-5-1, Electrostatics - Protection of electronic devices from electrostatic phenomena - General requirements

EN61340-5-2, Electrostatics - Protection of electronic devices from electrostatic phenomena - User guide



RF transmitter/receiver properties

Some LINAK products emit RF-power by intention for communication purposes.

Frequency band of transmission: 2402 MHz - 2480 MHz

Type: Bluetooth® Low Energy

Modulation: GFSK

Maximum Effective Radiated Power (ERP): 10 dBm

FCC and IC Statements

For RF-emitting products (e.g. Bluetooth®, Wi-Fi) intended to be used on the North American continent, the following applies:

FCC statement

NOTE: This equipment has been tested and found to comply with the limits for a Class B digital device, pursuant to part 15 of the FCC Rules. These limits are designed to provide reasonable protection against harmful interference in a residential installation. This equipment generates uses and can radiate radio frequency energy and, if not installed and used in accordance with the instructions, may cause harmful interference to radio communications. However, there is no guarantee that interference will not occur in a particular installation. If this equipment does cause harmful interference to radio or television reception, which can be determined by turning the equipment off and on, the user is encouraged to try to correct the interference by one or more of the following measures:

- Reorient or relocate the receiving antenna.
- Increase the separation between the equipment and receiver.
- Connect the equipment into an outlet on a circuit different from that to which the receiver is connected.
- Consult the dealer or an experienced radio/TV technician for help

Changes or modifications not expressly approved by the party responsible for compliance could void the user's authority to operate the equipment.

This device complies with Part 15 of the FCC Rules. Operation is subject to the following two conditions:

- (1) this device may not cause harmful interference, and
- (2) this device must accept any interference received, including interference that may cause undesired operation.

IC statement

This device contains licence-exempt transmitter(s)/receiver(s) that comply with Innovation, Science and Economic Development Canada's licence-exempt RSS(s). Operation is subject to the following two conditions:

- (1) This device may not cause interference.
- (2) This device must accept any interference, including interference that may cause undesired operation of the device.





















L'émetteur/récepteur exempt de licence contenu dans le présent appareil est conforme aux CNR d'Innovation, Sciences et Développement économique Canada applicables aux appareils radio exempts de licence. L'exploitation est autorisée aux deux conditions suivantes :

- (1) L' appareil ne doit pas produire de brouillage;
- (2) L' appareil doit accepter tout brouillage radioélectrique subi, même si le brouillage est susceptible d' en compromettre le fonctionnement.



Symbols

The following symbols are used on the LINAK product labels, where applicable:

	IEC 60417-5172: Class II equipment		Compliance to all relevant EC directives
	IEC 60417-5840: Applied part type B		UK Conformity Assessment
	IEC 60417-5019: Class I equipment Protective earth; protective ground		Regulatory compliance mark: The Australian Safety/EMC Regulations
	IEC 60417-5002: Positioning of cell		Alternating current
	ISO 7000-0434A: Caution, consult accompanying document		Direct current
	ISO 7000-1641 Operating instructions		Reduced ETL recognised component mark for Canada and the United States. X: The mark is always accompanied by a control number of 6 or 7 figures. For complete description, see ETL marking on next page.
	Electronics scrap		
	Electronics scrap		Bluetooth®
 Li-ion	Recycle		Japanese TELEC
	Recognised Component mark for Canada and the United States		
	PSE diamond mark		
	PSE circle mark		

Electrical Testing Laboratories (ETL) marking

Due to space limitations, the complete ETL marking demands are not represented on the marking plates.

The full ETL recognised component markings are shown here:



C/N 120690
 Conforms to ANSI/AAMI Std. E560601-1
 Cert. to CSA Std. C22.2 No. 60601-1



C/N 4008004
 Conforms to ANSI/AAMI Std. E560601-1
 Cert. to CSA Std. C22.2 No. 60601-1



C/N 4008838
 Conforms to ANSI/AAMI Std. E560601-1
 Cert. to CSA Std. C22.2 No. 60601-1



C/N 9901916
 Conforms to ANSI/AAMI Std. E560601-1
 Cert. to CSA Std. C22.2 No. 60601-1



C/N 4008005
 Conforms to ANSI/AAMI Std. E560601-1
 Cert. to CSA Std. C22.2 No. 60601-1



C/N 4008671
 Conforms to ANSI/AAMI Std. E560601-1
 Cert. to CSA Std. C22.2 No. 60601-1



C/N 4008003
 Conforms to ANSI/AAMI Std. E560601-1
 Cert. to CSA Std. C22.2 No. 60601-1



C/N 4008623
 Conforms to ANSI/AAMI Std. E560601-1
 Cert. to CSA Std. C22.2 No. 60601-1



C/N 4009507
 Conforms to ANSI/AAMI Std. E560601-1
 Cert. to CSA Std. C22.2 No. 60601-1



Batteries









To comply with the EU Battery Regulation (EU) 2023/1542, battery-related information is provided through this QR code.



Scanning the QR code gives access to battery identification details, as well as safety and environmental information available on the LINAK website.

This information must also be included in the end-product user manual.

General battery warnings

-  Handle batteries carefully. Do not short circuit the battery.
-  Avoid continuous battery discharge when the medical device is not in use, as this may cause lead sulphate formation, which, if left in this state for too long, will irreversibly damage the battery.
-  LINAK battery packs may emit flammable gases. Do not expose the battery packs to fire or equipment that emits sparks. Moreover, do not store the battery in a closed environment or incorporate it into a closed structure of an enclosure as this may cause an explosion, fire, equipment damage, or injury.
-  Handle tools carefully and do not wear jewelry when handling batteries. A short-circuit of the battery terminals can cause burn injuries, damage or trigger explosions.
-  Only connect LINAK batteries to compatible chargers.
-  LINAK battery packs contain toxic substances. If the internal battery fluid leaks out and gets onto skin or clothing, make sure it is washed off with clean water. Moreover, if the fluid gets into the eyes, rinse them immediately with clean water and seek medical assistance.
-  Do not use or store LINAK battery packs in places where the ambient temperature exceeds 50 °C, such as inside a hot automobile, in direct sunlight, or in front of a stove or a source of intense heat. Doing so can shorten the battery life, lower its performance level, cause the battery to leak fluid, explode, cause fire, or be damaged.
-  Applications where batteries serve as backup and not as the main power source should always be connected to mains whenever possible.

Lithium ion batteries

Li-Ion batteries are moving in the direction of minimising the physical size and, at the same time, increasing the capacity. This gives a very compact battery with a high energy concentration. It also increases the risk of thermal runaway (see note below) due to internal short circuits.

The general use of Li-Ion batteries has increased, and the inherent risk of thermal runaway has led to stricter rules within the transport industry, specifically air transport with tightened restrictions on the quantity, handling, and storage of specific products.

The OEMs and consumers must recognise that although safe to use, Li-Ion cells always have a very small risk of thermal runaway. The risk could be as little as 1 PPM or even less.

LINAK currently bases our Li-Ion battery design on cell types with an industry-proven history (e.g. electric cars). The use of well-proven cell technology reduces the risk of thermal runaway, but it does not eliminate it. LINAK has completed activities to reduce this risk and the complete battery package is approved in accordance with UL.

An external, internationally recognised expert has also reviewed the design to ensure that it is manufactured according to the latest recommendations. Further to that, we only use cells from well-recognised manufacturers.

LINAK recommends that when using Li-Ion batteries, the customers should carry out proper risk analysis on their application. The risk analysis must also take into consideration that these products are not mounted in positions where they are in direct contact with flammable materials.

LINAK Li-Ion batteries have no greater risk of thermal runaway than other Li-Ion cells from well-recognised manufacturers within the market. Therefore, LINAK cannot take responsibility for any failures that occur due to a failure that is inherent in the nature of Li-Ion batteries.

If any of the Li-Ion batteries built into LINAK products are found to be defective under warranty, LINAK will provide the OEM with a new product. LINAK explicitly disclaims all other remedies. LINAK shall not in any event be liable under any circumstances for any special indirect punitive incidental or consequential damages or losses arising from any incident related to the inherent risk of thermal runaway in the Li-Ion cell and any use of LINAK products. Moreover, LINAK explicitly disclaims any responsibility for profit loss, failure to realise expected savings, any claim against our customer by a third party, or any other commercial or economic losses of any kind, even if LINAK has been advised of the possibility of such damages or losses.

Note: 'Thermal runaway' is overheating of a cell, and it could lead to a small fire and smoke from the cell.











Transportation

The lithium ion batteries must be packed and transported in accordance with applicable regulations. Always ask your local transportation provider how to handle the transportation of lithium ion batteries.





Please see the general assembly instructions and the mounting section for detailed information.









Warnings

-  When using Li-Ion batteries with patient lift control boxes, loss of power might happen due to the battery deep discharge protection. This will only happen in case of continuous battery use despite warnings. In this event, there may be no warning, and the application may not be able to move when expected.
-  In his risk analysis, the customer must take into consideration how to assure alternative means to make movement, for instance quick release or manual lowering.
-  Do not open the battery housing as damaging the cell or circuitry may develop excessive heat.
-  If product caution is not clearly visible at low light intensity, read the product label instructions symbol. A warning must be included in the application manufacturer manual for the medical device.
-  The application manufacturer must test the application and ensure that intentional and unintended operations do not exceed the battery specification limits.
-  Defective or damaged Li-Ion batteries are not allowed for transportation.
-  For safety reasons, please adhere to the indicated charging and operation temperature.
-  In case the battery is too hot, disconnect it, evacuate the room, and wait for 2 hours before taking further steps.
-  Mounting instructions must be followed in order to avoid exposing batteries to water.
-  In general, recharging of batteries must take place every 12 months. However, please note:
 - New Li-Ion batteries, shipped from LINAK are in a deep-sleep state, where the self-discharge is very little
 - When mounted in an application, LINAK Li-Ion batteries wake up, resulting in a higher rate of charge, depending on the application/system
 - Application manufacturer must consider this idle consumption for his specific system and make precautions to avoid discharged batteries.
 - Contact your LINAK sales team for further information
-  If batteries are to be shipped by air, they shall not be charged to more than 30%
-  Disposal of the battery takes place in accordance with local regulations.

Recommendations

-  Do not exceed the storage temperature as it will shorten the product life and performance.
-  Allow the battery to settle to room temperature before use.
-  Lithium ion batteries are not intended for use in outdoor applications and indoor pool environments.
-  If the battery is completely discharged, then recharge the battery before storage.
-  Always use correct LINAK charger

DO NOT:

-  Heat or burn the batteries.
-  Expose the batteries to high impact/excessive force.
-  Crush or puncture the batteries.
-  Use batteries with signs of damage or corrosion.
-  Charge or store the batteries near combustible material.
-  Exceed IP-ratings.
-  Overcharge or fully discharge the batteries.

Safety feature

Lithium ion batteries contain several mechanisms to protect themselves from being damaged due to excessive use. In case of overheating, the device will activate a thermal protection. No power output will be available until the temperature is again within normal operating range.

Overheating may occur by extensive use at high temperatures or when exceeding the duty cycle (see product label).

Lead acid batteries

Maintenance of batteries

Prior to first use of LINAK® batteries, please make sure that they are charged at least 24 hours and if possible even longer for proper functioning and prolonging the battery lifetime.







Replacement of batteries

The batteries must only be replaced by the same type of batteries or mechanical and electrical equivalent types. The batteries must be new or maintained by means of charging at least every 6 months. The batteries, which make a set, must be supplied with identical production codes.

Production code mismatch may lead to a severely reduced lifetime expectancy.

Before mounting, ensure that the battery set is correctly connected, compare with the drawing in the battery room and check that no connectors are loose.

Warnings in connection with battery replacement

-  Please observe the following maintenance, replacement, and disposal requirements to ensure a safe and reliable operation.
-  The batteries are to be replaced after 4 years at the latest. Perhaps earlier, depending on the pattern of use. Frequent and high-powered discharges reduce the battery life. For an optimum lifetime, the product must be connected to the mains voltage as often as possible. It is recommended that the batteries are to be charged for at least every 6 months - otherwise the batteries will have reduced capacity due to self-discharge. It is recommended to test the battery function at least once every year.
-  The battery compartment is hermetically separated from the electronics compartment. When replacing the batteries this separation must not be damaged or modified as this may allow penetration of battery gas into the electronics compartment with risk of explosion.
-  When replacing batteries in waterproof products (IPX5 and IPX6), precautions must be taken that the sealing material (silicone ring or joint filler) is not damaged and that it is correctly placed in the groove. Hereafter, the screws in the cover are to be fastened with approx. 1 Nm. If necessary, replacement sealing is available at LINAK.
-  The battery compartment is supplied with ventilation that ensures correct and necessary airing of the battery compartment. This airing must not be blocked or covered as a positive pressure may occur with risk of explosion.
-  If the product has been exposed to mechanical overload (lost on the floor, collision/squeezing in the application or a powerful stroke), the product must be sent to an authorised workshop for control of the hermetic separation between the battery and electronics compartment.

Disposal

Lead acid batteries must be disposed of in the same way as car batteries. Alternatively, they may be returned to LINAK.

System description

LINAK® actuators, lifting columns and electronics have been developed for use in all places where a linear movement is required.

LINAK products can for example be used for:

- Adjustment of beds
- Patient lifts within the care and hospital sector
- Adjustment of dentist chairs/gynaecological chairs

Connecting the system

Do not connect the mains cable until all actuators and hand controls have been connected to the control box.

Start by connecting the hand control to the control box. The connection in the control box is marked with "HB".

Connect the different actuators to the different channels on the control box. Each channel is marked with a number (e.g. "1", "2", "3".....).

Check that all plugs are well connected and firmly pushed into the connector. Due to the fact that LINAK® control boxes are designed for a high IP degree, a firm force can be required.

Connect the mains cable.

The actuators can now be operated by pressing a button on the hand control button.

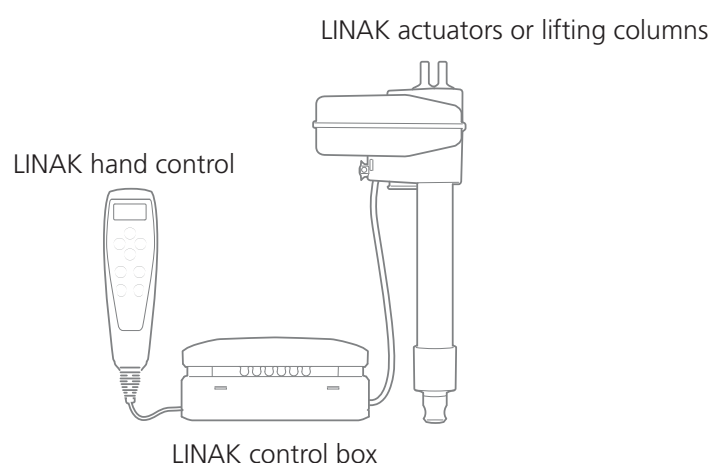

Any non-detachable power supply cord with mains plug is considered to be the disconnecting device.

Charging is only allowed in dry environment, and the appliance inlet must be thoroughly dried before connecting to mains.

General mounting of accessories

- The mounting screws on accessories must be tightened with a maximum torque of 1 Nm
- The mounting surface to which the accessory is attached should have a surface evenness of more than ± 0.5 mm
- Systems must not be installed/deinstalled while in operation
- Nuts and bolts must be made of steel
- Nuts and bolts must be tightened securely



General environmental conditions

Operating, storage and transport	
Operating temperature	+5 °C to +40 °C
Relative humidity	20% to 80% - non-condensing
Atmospheric pressure	700 to 1060 hPa (Rated to be operated at an altitude \leq 3000 m)
Storage temperature	-10 °C to +50 °C
Relative humidity	20% to 80% - non-condensing
Atmospheric pressure	700 to 1060 hPa (Rated to be stored at an altitude \leq 3000 m)
Transport temperature	-10 °C to +50 °C
Relative humidity	20% to 80% - non-condensing
Atmospheric pressure	700 to 1060 hPa (Rated to be transported at an altitude \leq 3000 m)
These values apply unless specified otherwise in the product-related texts.	



Information on start-up, deinstallation and operation

Before installation, deinstallation or troubleshooting

- Stop the actuator/lifting column.
- Switch off the power supply or pull out the mains plug and pull out the plug to the actuator/lifting column.
- Relieve the actuator/lifting column of any loads, which may be released during the work.

Before start-up

- Make sure that the system has been installed as instructed in the relevant product manual.
- The individual parts (actuator/lifting column/hand controls etc.) must be connected before the control box is connected to the mains.
- Make sure that the mains voltage to be connected to the product or the system is the one stated on the label.
- The equipment can be moved freely over the whole working area of the actuator/lifting column.
- Check correct function after mounting.
- The actuator/lifting column must not be loaded in excess of the values indicated in the specifications on the product label.
- The duty cycle noted on the product label must always be observed. Otherwise there is a risk of product damage. Exceeding the duty cycle will result in a dramatic reduction of the system lifetime.
- Unless specified otherwise on the product label, the duty cycle is max. 10%, max. 2 minutes in use followed by 18 minutes not in use.
- The actuator/lifting column system may only be used in an environment corresponding to the IP rating of the system. LINAK products are marked with the actual IP rating on the label.
- If the actuator is assembled in the application and is exposed to push or pull during transportation, the actuator can be damaged.
- If any individual parts are suspected to be damaged, do not install the parts, but return them for inspection/service.

During operation

- Check for unusual sounds and irregular movement. Stop the actuator/lifting column immediately if anything unusual is observed.
- If the control box makes unusual noises or smells, switch off the mains voltage immediately and the external battery, if any.
- Take care that the cables are not damaged.
- Unplug the mains cable on mobile equipment before it is moved.



Cleaning

The products can be cleaned as described in the following according to their IP protection stated on the product label.

The IP code specifies the protection degree provided by the enclosures. For most products, only the protection against ingress of water (second characteristic numeral) is specified, ingress of solid foreign objects or dust (first characteristic numeral) is not specified and therefore replaced by the letter X in the code. However, it should be noted that compliance with the requirements of IEC 60601-1 automatically allows to rate the medical equipment as IP2X because the requirements of IEC 60529 for this rating are the same as the accessibility requirements.

IP protection	Cleaning instructions
IPX0	Clean with a damp cloth
IPX1	Clean with a damp cloth
IPX2	Clean with a damp cloth
IPX3	Clean with a damp cloth
IPX4	Clean with a damp cloth
IPX5	Wash with a brush and water, but not water under pressure
IPX6	Wash with a brush and water. The water can be under pressure, but the system must not be cleaned directly with a high pressure cleaner. Max. 20 °C
IPX6 Washable according to IEC 60601-2-52	Clean by the use of wash tunnels according to IEC 60601-2-52
IPX6 Washable DURA™	Clean by the use of wash tunnels according to IEC 60601-2-52, extended washing cycle test

To avoid degreasing of the piston rod, the actuator should be retracted to minimum stroke and without load before washing.

Cleaning warnings



The systems must not be sprayed directly with a high pressure cleaner.



Interconnecting cables must remain plugged in during cleaning to prevent water ingress.



Cleaning with a steam cleaner is not permitted



UV cleaning is not permitted.

IPX6 Washable

LINAK® washable products frequently undergo a fully regulated washing test.

At LINAK, 'IPX6 Washable' means that the products conform only to this test.

Standard washing procedure

- Reference:** The standard IEC 60601-2-52 newest revision, which includes special demands to fundamental safety and relevant functional characteristics for hospital beds. The demands for the washing process are described in the German "Maschinelle Dekontamination" from the organisation AK-BWA (Arbeitskreis Bettgestell- und Wagen-Dekontaminationsanlagen).
- Description:** At LINAK, the washing test takes place in an instrument washing machine, which is fitted and programmed in such a way that it duplicates the process used in a typical hospital installation for the cleaning of beds and other medical equipment. During the test, the products are exposed to both thermal and chemical effects. To avoid degreasing of the piston rod, the actuator should be retracted to minimum stroke and without load before washing.
- Preparation:** As plastic materials to a larger or lesser degree change characteristics and shape with time and climatical exposure, an ageing of the products is carried out first. The conditions for ageing are 65 °C +/- 2 °C in normal dry air for 10 days followed by a minimum of 16 hours at room temperature before the washing process starts.
- Water:** Degree of hardness, no more than 5° dH and no demineralised water.
- Detergents:** **LINAK recommends the following products:**
- Sekumatic FDR or FRE from Ecolab
 - Neodisher Dekonta from Dr. Weigert
 - Thermosept NDR from Schülke or similar with a pH-value of 5 - 8 and in a concentration of 0.5 %



Rinsing aids

LINAK® recommends the following products:

- Sekumatic FKN from Ecolab
- Neodisher BP or TN from Dr. Weigert
- Thermostept BSK from Schülke or similar with a pH-value of 5 - 8 and in a concentration of 0.2 %.

Demands to chemicals:

- They must not contain caustic solutions
- They must not change the surface structure or adhesive properties of the plastic
- Must not break down grease

LINAK washing profile according to IEC 60601-2-52

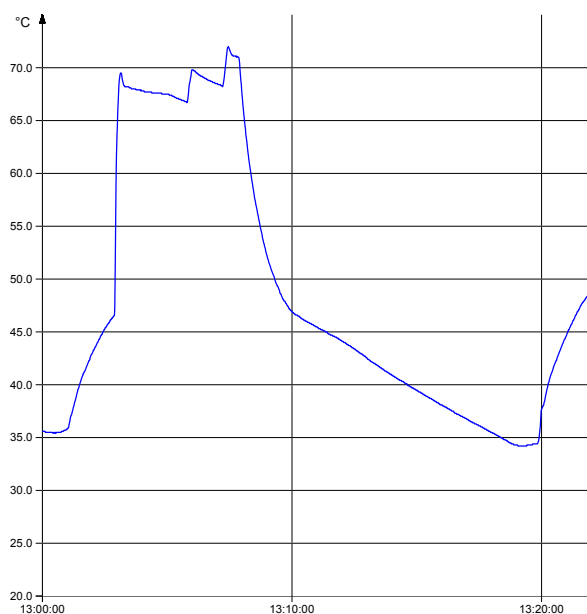

LINAK washing machine



IPX6 Washable DURA™

Description of washing test

LINAK washable products frequently go through a fully controlled washing test. The LINAK term “IPX6 Washable DURA” signifies that the products conform exclusively to this test.

The “IPX6 Washable DURA” washing test is used to ensure that products that are rated “IPX6 Washable DURA” comply with the agreed terms and conditions. This washing test differs from the norm EN60601-2-52 as the products are not aged and each washing cycle is followed by a 30 minute cooling process.

Further information regarding the washing process can be found in the German document “Maschinelle Dekontamination” from the organisation AK-BWA.

Estimated time consumption: Approximately 1 month.

Amount of samples: During the development process, the number of tested samples is in accordance with GP082. During running production, the number of tested samples complies with UM-41-22-001.

General: The process applies to the IPX6 Washable DURA system.

Test conditions:

- The units are not aged.
- Products with adhesive foils must be hardened before ageing.
- The hardening time depends on the used adhesive, but is typically 3 days at 20°C.
- The units are washed with new plugs/cables.
- The cables should be as long as possible and free ends should be shut off.
- Detergent and rinsing aids used:
 - Detergent 1: DR. WEIGERT neodisher Dekonta AF
 - Rinsing aid 1: DR. WEIGERT neodisher TN

Test procedure:

- The units are placed in the washing machine in the intended mounting direction (in the most sensible direction regarding water penetration, if this is not the same direction).
- The washing process (see picture below) is repeated 11 times and consists of:
 - Washing with 0.3 % alkaline detergent for 2 minutes in 70 °C hot water. (Note: the temperature is measured in the tank, not necessarily at the unit).
 - Rinsing with neutral rinsing aid for 20 seconds.
 - Drying and cooling for 30 minutes in the open air at approx. 20 °C.
- After 11 cycles, the products are left in a ventilated room for 24 hours. The above steps are repeated until a total of 250 cycles has been reached.
- Immediately after washing and after further 24 hours, the products are subjected to a high voltage test in accordance with UM-31-30-072.
- A population sample of the products is opened for water penetration control immediately after the washing test. Accept criteria are in accordance with UM-20-30-002.

Options: The following options can be used for the test:

- The units may be weighed prior to and after the washing test to detect water.
- The bubble test may be used to detect any leakages.
- X-ray may be used to detect any leakages.



LINAK washing profile for the "IPX6 Washable DURA" process

LINAK washing profile according to DURA™

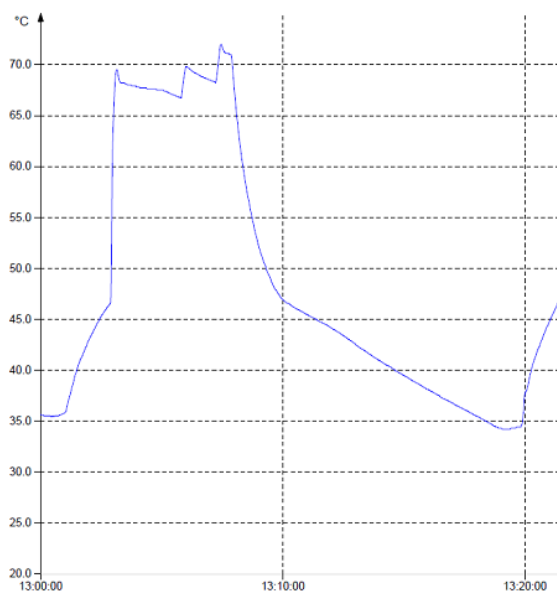

(Note: The temperature is measured at the unit)

LINAK washing machine



Cable wash

Before the washing procedure starts

In order to maintain the flexibility of the cables, it is important that the cable is placed in such a way that the cable's own weight does not strain the coil during the washing process. This can be done by placing the cable ON the bed or another form of support for the cable. Please see the examples in the picture to the right.



General maintenance

If not otherwise stated in the specific product section.

- LINAK products must be cleaned at regular intervals
- Frequent inspection for malfunction, mechanical damage, wear and cracks. Worn-out parts must be replaced
- Inspection/maintenance intervals are to be recommended by the medical device manufacturer
- LINAK products are closed units and require no internal maintenance
- LINAK products must be IPX6 Washable and IPX6 Washable DURA when cleaning in wash tunnels
- O-rings: When individual parts are replaced in a LINAK IPX6, IPX6 Washable or IPX6 Washable DURA system, the O-rings must be replaced at the same time on all parts. On all products where replaceable cables or fuses have been dismantled or replaced, the O-ring must be replaced, and the O-rings and the receptacle insert must be greased with an acid-free Vaseline.

Maintenance of all LINAK accessories

- Electronics must be inspected at attachment points, wires, enclosure, and plugs
- Inspect the connections, cables, enclosure, and plugs, and check for correct functioning
- LINAK electronics are maintenance-free (however, this does not apply to lead acid batteries)



Repair and disposal

Only an authorised LINAK® service centre should repair the LINAK actuator systems. Systems to be repaired under warranty must be sent to an authorised LINAK service centre.

In order to avoid the risk of malfunction, all actuator repairs must only be carried out by an authorised LINAK Service shop or repairers, as special tools and parts must be used.

If a system is opened by unauthorised personnel there is a risk that it may malfunction at a later date.

LINAK systems or components may be disposed of, possibly by dividing them into different waste groups for recycling or combustion.

We recommend that our product is disassembled as much as possible at the disposal and that you try to recycle it. LINAK systems or components should be disposed of in accordance with the environmental regulations applicable in the respective country.



Insulation class

LINAK® control boxes are available in insulation Class I and insulation Class II.

Output ratings

Nominal values:

On LINAK® control boxes, battery boxes and power supply marking plates, the nominal output voltage at a certain load for a certain product may be stated.

Depending on product and load, this value may vary significantly due to construction.

The expected output voltage may for instance vary depending on product and load within a range from approximately 20 V DC to approximately 50 V DC for a product with a nominal output voltage of 24 V DC due to the construction.

When combining LINAK control boxes, battery boxes and power supplies with other LINAK components, compatibility is ensured. When combining LINAK control boxes, battery boxes or power supplies with third party products, special precautions may be taken. In this case, contact LINAK.



Troubleshooting

Symptom	Possible cause	Action
No motor sound or movement of piston rod	<ul style="list-style-type: none"> - The actuator is not connected to the control box - Blown fuse in the control box - Cable damaged 	<ul style="list-style-type: none"> - Connect the actuator to the control box - Fuse must be changed - Send actuator for repair
Excessive electricity consumption		<ul style="list-style-type: none"> - Send actuator for repair
Motor runs but spindle does not move	<ul style="list-style-type: none"> - Gear wheel or spindle damaged 	<ul style="list-style-type: none"> - Send actuator for repair
Actuator cannot lift full load	<ul style="list-style-type: none"> - Clutch is worn - Motor is damaged 	<ul style="list-style-type: none"> - Send actuator for repair
Motor sound but no movement of piston rod		<ul style="list-style-type: none"> - Send actuator for repair
No signal from Reed or Hall switch		<ul style="list-style-type: none"> - Send actuator for repair
Motor runs and quick release does not function or is noisy	<ul style="list-style-type: none"> - Declutching arm turns less than approx. 75 °C 	<ul style="list-style-type: none"> - Adjust cable
Piston rod will only move inwards and not outwards	<ul style="list-style-type: none"> - Safety nut has operated 	<ul style="list-style-type: none"> - Send actuator for repair
	<ul style="list-style-type: none"> - Not connected to mains 	<ul style="list-style-type: none"> - Connect to mains
Power indicator does not light up	<ul style="list-style-type: none"> - The fuse has blown 	<ul style="list-style-type: none"> - Replace fuse, if the system is prepared for external fuse replacement, or send the system for repair
	<ul style="list-style-type: none"> - Defective power cable 	<ul style="list-style-type: none"> - On control boxes with exchangeable power cable, change the cable. - On control boxes with fixed cable, send it for repair
	<ul style="list-style-type: none"> - Control box defective 	<ul style="list-style-type: none"> - Send control box for repair
	<ul style="list-style-type: none"> - Actuator plug not pushed into control box properly 	<ul style="list-style-type: none"> - Push actuator plug properly into control box
Power indicator lights up, but actuator does not run	<ul style="list-style-type: none"> - Actuator defective 	<ul style="list-style-type: none"> - Replace actuator - Defective control box - Replace the control box
Control box relays are clicking	<ul style="list-style-type: none"> - Control box defective 	<ul style="list-style-type: none"> - Send control box for repair
Power indicator lights up, but actuator does not run	<ul style="list-style-type: none"> - Hand control defective 	<ul style="list-style-type: none"> - Send hand control for repair
No relay noise is heard from control box Not valid for CB20/CB6S OBF/CB16 OBF	<ul style="list-style-type: none"> - Battery completely flat 	<ul style="list-style-type: none"> - Charge battery
Control box completely dead on battery and no relay clicking	<ul style="list-style-type: none"> - Battery defective 	<ul style="list-style-type: none"> - Replace battery
	<ul style="list-style-type: none"> - Actuator plug not properly pushed into control box 	<ul style="list-style-type: none"> - Push actuator plug properly into control box
Actuator does not run on battery, but relay clicking can be heard	<ul style="list-style-type: none"> - Actuator defective 	<ul style="list-style-type: none"> - Replace actuator
	<ul style="list-style-type: none"> - Control box defective 	<ul style="list-style-type: none"> - Replace control box
	<ul style="list-style-type: none"> - Hand control defective 	<ul style="list-style-type: none"> - Send hand control for repair
	<ul style="list-style-type: none"> - Control box defective 	<ul style="list-style-type: none"> - Send control box for repair
Control box okay apart from one direction on one channel		



BA15



The BA15 is a backup battery box developed for use together with LINAK actuator systems powered via an external SMPS (Switch Mode Power Supply).

Usage

Compatibility:	BA15 is compatible with LINAK actuator systems powered via an external power supply
Duty cycle:	10%, 2 minutes continuous use followed by 18 minutes not in use
Charging:	Via integrated charger
Charging time:	Approx. 6 hours
Recharging during storage:	Battery recharging no later than 6 months after production
Operating temperature:	+5 °C to +40 °C
Storage temperature:	-15 °C to +40 °C The batteries must be stored in an applicable storage room without direct sunlight
Relative humidity:	20% to 80% - non-condensing
Atmospheric pressure:	700 to 1060 hPa
Height above sea level:	Max. 3000 meters
Service:	Battery cells cannot be replaced as the battery cover cannot be closed properly afterwards.
Approvals:	IEC60601-1 ANSI/AAMI ES60601-1 CAN/CSA-22.2 No. 60601-1

LED functionality



LED	Indication of operation
Solid yellow	Charging
No LED light	Fully charged

Buzzer functionality

The buzzer will make a warning when a button on the hand control is pressed and the battery capacity is low.

Battery operation

BA15 must have T-cable to function, use CABL00057 BA15 T-cable.



Information

If a T-cable is installed in the system, the battery must be connected; otherwise, the SMPS10 cannot supply power to the system.

Battery interface

Battery T-cable connection:

J1 = Control box (4-pin mold)

J2 = BA15 (6-pin mold)

J3 = SMPS (4-pin mold extension)



Battery with control box example

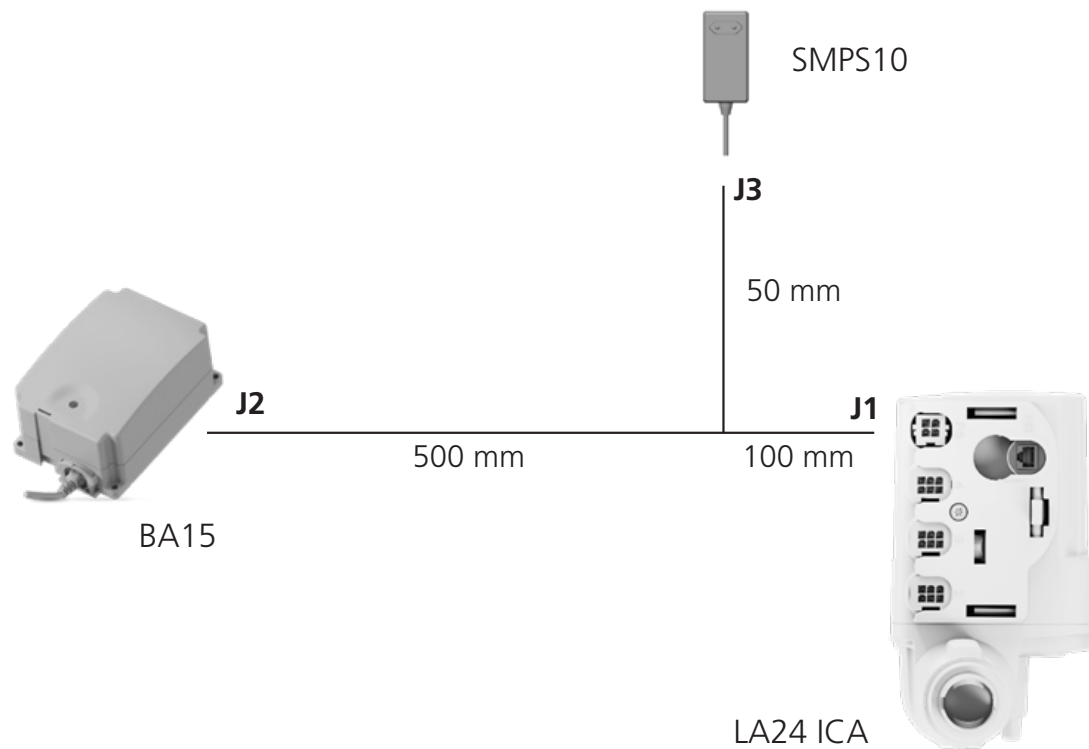

Mounting instructions

BA15 can either be mounted with M4 screws or by means of a mounting bracket.

Make sure the surface touching the BA15 mounting surface is flat and use all 4 screws.

The diameter of the screw cap must be maximum 8 mm.

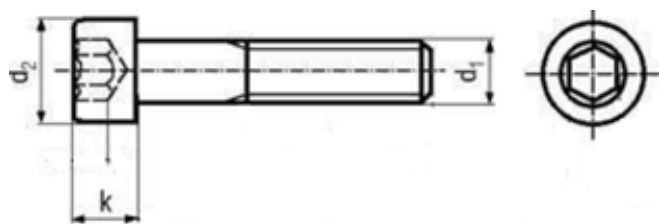

Information

To mount BA15 using the mounting bracket, it must be positioned with the bottom facing down.

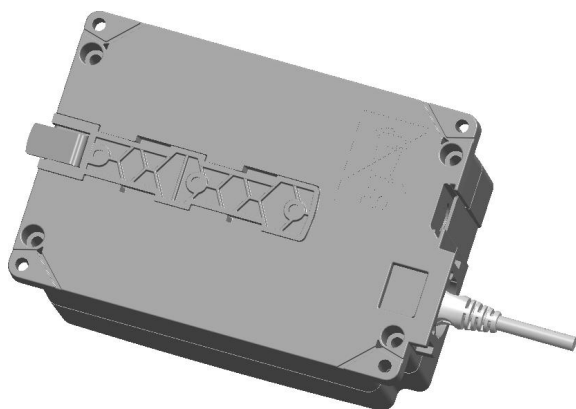



Recommendations

- Do not exceed the storage temperature as it will shorten the product life and reduce performance.
- Allow the battery to settle to room temperature before use.
- Do not exceed the duty cycle 2/18 as it will shorten the life, reduce performance, and eventually activate overcurrent protection.
- BA15 is not intended for use in outdoor applications.
- If the battery is completely discharged, then recharge the battery before storage.
- Inspect at regular intervals that the ventilation aperture is positioned correctly and is intact throughout its length.
- If a T-cable is installed in the system, the battery must be connected; otherwise, the SMPS10 cannot supply power to the system.

Safety features

- BA15 contains overcurrent protection for safety and to protect itself from being damaged due to excessive use.
- When current protection is activated, no power output will be available.



Warnings

- Loss of power might happen due to activation of overcurrent protection. In this event, there may be no warning and the application may not be able to move when expected.
- Defective or damaged batteries may leak acid and adequate precautions must be taken during handling and transportation.
- Do not open the battery case as damage to the cell or circuitry may develop excessive heat.
- It is important for users to read the guidelines in the “User Manual Linear Actuators and Electronics”.
- Do not short circuit the battery.
- Only use the specified external SMPS together with BA15 for charging
- If disposed to fire, the battery may explode.
- The battery box BA15 itself may not be combined with an external charger.

If product caution is not clearly visible on the final application at low light intensity, the above mentioned warnings must be integrated in the application manufacturer manual.

The application manufacturer must test the application and ensure that neither intended nor unintended use exceeds the battery specification. The application manufacturer must assure other means of movement, e.g. quick release or manual lowering in case of battery failure.

Information

The BA15 has a built-in charger and is therefore not able to operate with control boxes with charger. Be aware that the BA15 is only compatible with external power supply solutions.

LINAK batteries and safety

LINAK batteries for medical use are designed and manufactured to be safe throughout the product life. LINAK has performed various battery tests in normal use, abuse, and failure situations to verify design and production methods. These tests have not shown any unacceptable risks.

The batteries are UL-tested to verify the safety of the design and to obtain a safety certificate from an independent organisation. This means that UL regularly inspects the factory to check that standards are complied with.

BA16



The battery box BA16 is developed for use together with the LINAK CA and CO control box series to support power backup.

Usage

Compatibility:	Battery back-up for COxx and CAxx
Duty cycle:	10%, 2 minutes continuous use followed by 18 minutes not in use
Charging:	Via integrated charger
Charging time:	Approx. 6 hours
Recharging during storage:	Battery recharging no later than 6 months after production date stated on the label
Operating temperature:	+5 °C to +40 °C
Storage temperature:	-10 °C to +50 °C
	The batteries must be stored in an applicable storage room to avoid direct sunlight
Relative humidity:	20% to 80% - non-condensing
Atmospheric pressure:	700 to 1060 hPa
Height above sea level:	Max. 3000 meters
Service:	Battery cells cannot be replaced as the battery cover cannot be closed properly afterwards.
Approvals (pending):	IEC60601-1 ANSI/AAMI ES60601-1 CAN/CSA-22.2 No. 60601-1 UL tested in accordance with UL60601-1

LED functionality



LED	Indication of operation
Solid yellow	Charging (battery not ready)
No LED light	Fully charged (battery ready)
Flashing yellow	Error during charging

Buzzer functionality

The buzzer will make a warning when a button on the hand control is pressed and the battery capacity is low. The buzzer can also be activated by an intelligent control box to signal other conditions. This must be specified in the control box software.

Mounting instructions

BA16 must be mounted with M4 screws due to the battery weight.

Make sure the surface touching the BA16 mounting surface is flat and use all 4 screws.

The diameter of the screw cap must be maximum 8mm.

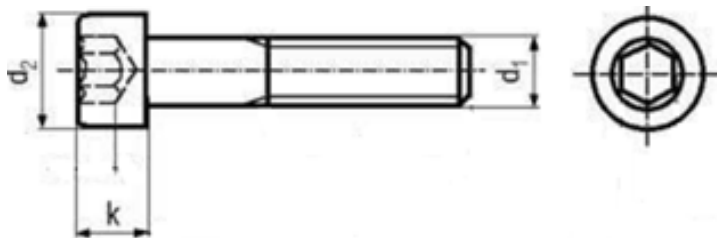

d_1	M4
$d_{2\max}$	8
k	4

According to ISO 2009

Mounting with bracket



Information

To mount BA16 Washable DURA with the mounting bracket, it is recommended to mount the battery bottom down.

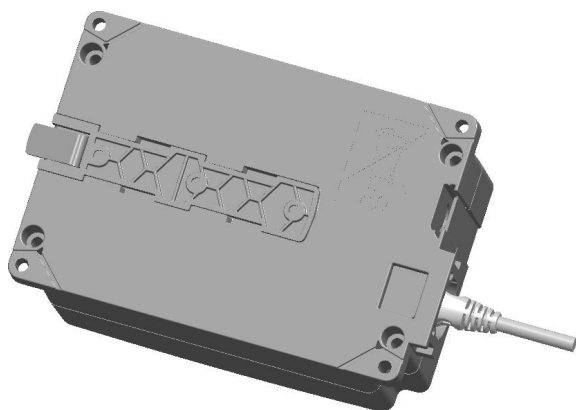

Cable

Cable	Mini-fit (4 pole) with angle to Mini-fit (4 pole) straight
Cable lock	0273044

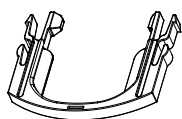
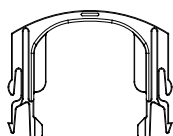



Warnings

- Loss of power might happen due to activation of overcurrent protection. In this event, there may be no warning and the application may not be able to move when expected.
- Defective or damaged batteries may leak acid and adequate precautions must be taken during handling and transportation.
- Do not open the battery case as damage to the cell or circuitry may develop excessive heat.
- It is important for users to read the guidelines in the “User Manual Linear Actuators and Electronics”.
- Do not short circuit the battery.
- Use the specified internal charger only.
- If disposed to fire, the battery may explode.
- The battery box BA16 itself may not be combined with an external charger.

If product caution is not clearly visible on the final application at low light intensity, the above mentioned warnings must be integrated in the application manufacturer manual.

The application manufacturer must test the application and ensure that neither intended nor unintended use exceeds the battery specification. The application manufacturer must assure other means of movement, e.g. quick release or manual lowering in case of battery failure.



Information

The BA16 has a built-in charger and is therefore not able to operate with control boxes with charger. Be aware that the BA16 is only compatible with CAxx and COxx.

BA16 safety

LINAK® batteries for medical use are designed and manufactured to be safe throughout the product life. LINAK has performed various battery tests in normal use, abuse, and failure situations to verify design and production methods. These tests have not shown any unacceptable risks.

The batteries are UL-tested to verify the safety of the design and to obtain a safety certificate from an independent organisation. This means that UL regularly inspects the factory to check that standards are complied with.



BA18

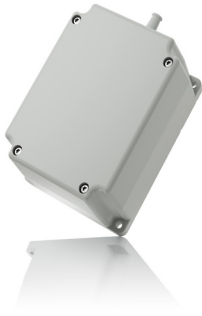

The BA18 is a cost-effective lead acid battery without integrated charger that can be used in combination with CO53 and with the long-established control box range, of which many are now legacy products.

Usage

Compatibility:	CO53, CB6P2 Legacy products : CB6, CB7, CB9, CB12, CB14, CB18, CB6S NOTE: (only specific versions may be compatible)
Ambient temperature:	+5 °C to +40°C
Charging:	Via LINAK® control box with integrated charging circuit
Charging time:	Approx. 6 hours depending on built-in control box charger
Recharging during storage:	Battery recharging no later than 6 months after production date stated on the label
Operating temperature:	+5 °C to +40 °C
Storage temperature:	-10 °C to +50 °C
Relative humidity:	20% to 80% non-condensing
Atmospheric pressure:	700 to 1060 hPa
Meters above sea level:	Max. 3000 meters
Approvals:	IEC60601-1 ANSI/AAMI ES60601-1 CAN/CSA-22.2 No. 60601-1

To ensure free passage of gasses when the battery is mounted on a flat surface the back side of the battery has been supplied with venting channels see below figure.

Venting channels and membrane on BA18:

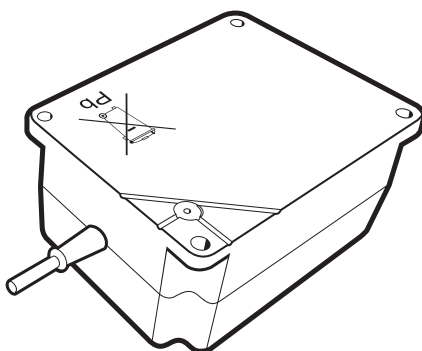



Warnings

- The battery case is only to be opened by authorised staff as incorrect handling may compromise the IP protection.
- Take care to always keep the venting channels free. Mounting plates must be rigid to prevent blocking of the venting channels.
- Do not use third party chargers.



Recommendations

- Allow the battery to settle to room temperature before use.
- The batteries must be stored in an applicable storage room to avoid direct sunlight.



BA22 Li-Ion



The BA22 Li-Ion battery pack, designed with additional mechanical safety features within its enclosure, is specifically developed for use with PCP 2.0 control boxes. This lightweight battery includes a built-in charger and boasts a 2.9 Ah capacity. It meets the IPX6 Washable standard and ensures high performance.

Usage

Compatibility:	PCP 2.0 control boxes
Duty cycle:	10%, 2 minutes continuous use followed by 18 minutes idle
Charging:	Integrated charger in battery
Charging time:	Up to 10 hours
Charging temperature:	+5 °C to +40 °C Charging at elevated temperatures can impact the charging time.
Charging state:	Maximum 30% when shipped from LINAK (The battery is shipped from LINAK in deep sleep and will be woken by charging)
Recharging during storage:	No need for charging during storage when the battery is in deep sleep. If the battery is woken up, it is recommended to fully charge the battery and recharge at least every 24 months.
Operation temperature:	+5 °C to +40 °C
Storage temperature:	-10 °C to +40 °C (+10 °C to +25 °C recommended) The batteries must be stored in an applicable storage room without direct sunlight.
Transportation temperature:	-20 °C to +40 °C
Relative humidity:	20% to 80% – non-condensing
Atmospheric pressure:	700 to 1060 hPa
Meters above sea level:	Max. 3000 meters
Warranty:	5 years
Approvals:	IEC60601-1 ANSI/AAMI ES60601-1 CAN/CSA-22.2 No 60601-1

All BA22 batteries produced in Denmark as of 1 January 2025 will have an extended warranty of 60 months (counting from manufacturing date).

All BA22 batteries produced prior to this date will follow the standard 12 months warranty period for batteries.



Information

For lithium batteries, the LINAK system only charges the battery to full if the battery level is below 80%. This is to avoid increased wear and increase the lifetime on the lithium cells inside the battery.



LED functionality



LED	Indication of operation
Solid orange	Charging
No LED light	Fully charged
Flashing orange	Error during charging

The LED functionality matrix below describes the battery behaviour when the control box is connected to mains.



Information

- The BA22 battery does not include a built-in buzzer. A buzzer can be added if using CO control boxes.
- The battery provides charging status information to the control box. This makes it possible to receive an indication via the control box to the hand control or in the Service Data Tool or OneConnect™.

Mounting instructions

The Battery Pack BA22 can be mounted in several ways on the bed/the application, either separately or together with the control box CO61. It is however not allowed to mount the battery in vertical position with the mounting clip pointing upwards - see illustration below:

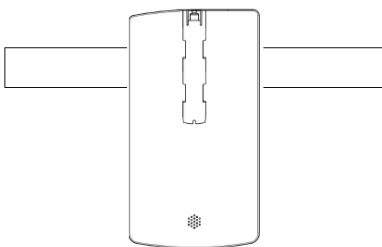

Ventilation

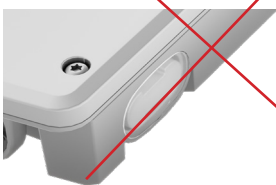

BA22 is equipped with clear vents, one on each side. These vents work both as a light guide for the LED charging indicator and as a pressure valve to ensure a safe battery performance.

When mounting the battery, ensure that there is an air gap of at least 5 cm on both sides to prevent blockage of the vents.

Transportation

The lithium ion batteries must be packed and transported in accordance with applicable regulations. Always ask your local transportation provider how to handle the transportation of lithium ion batteries.

Lithium ion batteries that are defective, have been damaged or have the potential of producing excessive heat or fire are not allowed for air transportation and must be disposed of locally.

For more information, contact your shipping department or shipping agent.



Recommendations

- Charge the battery fully before first use.
- Adhere to the battery storage temperature or else the lifetime and performance will be reduced.
- Allow the battery to settle to room temperature before use or charging.
- Adhere to the duty cycle or else the lifetime and performance will be reduced.
- BA22 Li-Ion is neither intended for use in outdoor applications, pool environments nor other harsh environments.
- Recharge the battery before storage if it has been completely discharged.
- Only charge with applicable LINAK control boxes.
- BA22 is not suitable for mounting via actuator bracket.

Safety feature

BA22 Li-Ion contains several mechanisms to protect itself from being damaged due to excessive use.

In case of overheating, the device will activate a thermal protection. No power output will be available until the temperature has returned to normal operating range. Overheating may occur by extensive use at high temperature.

BA22 safety

LINAK Li-Ion batteries for medical use are designed and manufactured to be safe through the product life. LINAK has performed various tests of the batteries in normal use, abuse and failure situations to verify the design and production methods. These tests have not shown any unacceptable risks.

The batteries are UL-tested to have an independent organisation verify the safety of the design and to obtain a safety certificate. This means that UL regularly inspects the factory to check that standards are complied with.

UL has tested in accordance with the following standards:

UN38.3 Battery Transportation Safety

IEC62133-2 Battery Safety



Information

BA22 has a built-in charger which means that it cannot operate with control boxes with charger. BA22 is compatible with CA63, CO61, CO65 and CO71.





Warnings

All Li-Ion battery users must read these important battery safety instructions before using Li-Ion batteries. Failure to read and follow Li-Ion safety instructions and warnings may lead to personal injury and equipment damage if the battery is charged and/or used improperly.

Lithium ion batteries differ from the lead acid technology as they have a built-in deep discharge protection.

In case of continuous use despite warnings, a power loss might occur due to the battery deep discharge protection. In this event, there may be no warning and the application may not be able to move when expected.

- The application manufacturer must test the application and ensure that intentional and unintended operations do not exceed the battery specification limits. The risk analysis for the final application must allow for the ensurance of alternative means to make movement, for instance quick release or manual lowering.
- If product caution is not clearly visible at low light intensity, read the product label instructions symbol. A warning must be included in the application manufacturer's manual for the medical device.
- Do not open, disassemble or modify the battery housing as cell or circuitry damage may develop excessive heat.
- Ensure that there is a minimum air gap of 5 cm on both sides of the battery to prevent blockage of the battery vents. Failure to do so may compromise safety and performance.
- Discontinue the battery use immediately if the battery emits an unusual smell, feels hot, changes colour or shape, shows signs of damage or corrosion or appears abnormal in any other way.
- In case the battery turns hot, disconnect and remove the battery from the room. If not possible to remove the battery, then evacuate the room.
- Defective or damaged lithium ion batteries or batteries that produce excessive heat or fire are not allowed for transportation.
- For safety reasons, please adhere to the indicated charging, storage, and operation temperature as extreme temperatures (low or high) might ignite the batteries and cause fire.
- The mounting instructions must be followed in order to avoid exposing batteries to water.
- The customer is responsible for determining that charger and host device work properly.
- Recharge batteries every 24 months as a minimum.
- Dispose of batteries in accordance with local regulations.

DO NOT:

- heat, burn or short circuit the batteries
- expose the batteries to high impact
- crush or puncture the batteries
- charge or store the batteries near combustible material
- charge the batteries without supervision
- submerge the batteries into water or other liquids

Any of the above mentioned can cause fire or injury.

LINAK® will remedy defective Li-Ion batteries built into LINAK products in accordance with the terms stipulated in the LINAK Li-Ion battery disclaimer available on the LINAK website. LINAK explicitly disclaims all other remedies and liability.



DIN Junction Box (DJB)



The DIN Junction Box is designed for use where there is a need for more than 1 or 2 controls to be connected to a control box.

The DIN Junction Box is constructed for connection of up to 4 controls with 8-pin DIN plugs. Furthermore, the box is constructed so that all channels for connection are placed on the same side of the box.

This gives the box a clean design and makes it easy to mount e.g. in a bed frame..

Usage

Compatibility:	CB9, CBJ
Operating temperature:	+5 °C to +40 °C
Storage temperature:	-10 °C to + 50 °C
Relative humidity:	20% to 80% non-condensing
Atmospheric pressure:	700 to 1060 hPa
Operational meters above sea level:	Max. 3000 meters
Latex free:	Yes
Approvals:	IEC 60601-1 ANSI/AAMI ES60601-1 CSA CAN/CSA-C22.2 NO. 60601-1 IEC 62366

Massage Motor



The massage motor can be added to all kinds of couches and tables, chairs or beds for treatment and examination. It enables comfort, relaxation and tension release for patients and clients. The massage motors are directly connected to the actuator port at the control box – no extra wiring at the application, simple and easy mounting.

Usage

Compatibility:	CB6S MK2 MJB006-0x to be used for OpenBus™ impulse drive
Duty cycle:	10%, 30 min. max.
Operating temperature:	+5°C to +40°C
Storage temperature:	-10°C to +50°C
Relative humidity:	20% to 80% - non-condensing
Atmospheric pressure:	700 to 1060 hPa
Height above sea level:	Max. 3000 meters
Approvals:	Medical approvals to be determined

Mounting

Massage motor on a plate

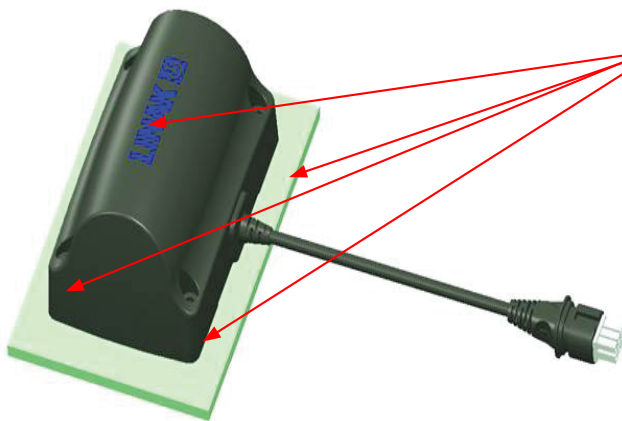

Is mounted with 4 screws

Mounting of the screw with max. torque 2Nm

Mounting of massage motor by using brackets

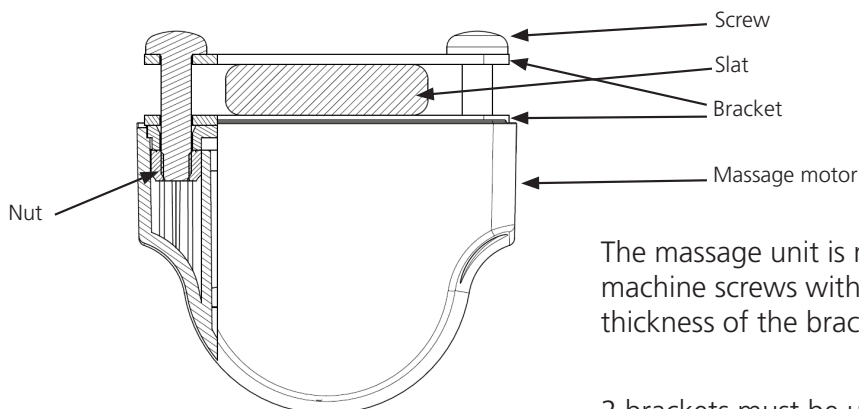

The massage unit is mounted with 4 x M6 roundheaded machine screws with flat underside. 15 to 20 mm long + the thickness of the bracket. Torque max. 2-3 Nm.

2 brackets must be used - one on each side of the slat.

Modular Junction Box - MJB2



The MJB2 is a compact 2-port repeater designed for use together with analogue or OpenBus™ control boxes. It is optimised for use in systems where 1 extra port is needed for easy connection of a hand control, a foot switch or an accessory like the UBL. It is easy to integrate in a wide range of healthcare applications such as hospital beds, surgery tables, and treatment chairs.

Usage

Operation temperature:	+5 °C to +40 °C
Storage temperature:	-10 °C to +50 °C
Compatibility:	Compatible with LINAK Bluetooth Low Energy (BLE) control boxes. Please contact LINAK.
Relative humidity:	20% to 80% – non-condensing
Atmospheric pressure:	700 to 1060 hPa
Meters above sea level:	Max. 3000 meters
Approvals:	IEC60601-1 ANSI/AAMI ES60601-1 CAN/CSA-22.2 No 60601-1



Recommendations

- Always use locking mechanism and O-ring.
- Unused socket(s) must be fitted with blind plug(s) to ensure the IP degree.
- When mounting, a screw torque 0.8-0.9 Nm is recommended.
- Hot-plugging: removing or adding any OpenBus™ cables is not allowed when the control box is powered by mains supply.

If still required, follow this procedure:

1. Remove mains and wait for 5 seconds
2. Connect or disconnect the required cables

Non-observance of this procedure may lead to a damaged OpenBus driver circuit.

The risk of a damaged circuit increases, if the accessory shows a high starting current or inrush current.



Warnings

- Using a wrong type of MJB2, for instance 10 wires in an OpenBus system, can lead to unintended movement or no movement.
- Using wrong screws or the wrong torque can lead to cracks in the housing.
- The cable is not to be exposed to high pull force or sideway traction.



Modular Junction Box - MJB5 Plus Port Repeater



The modular junction box MJB5 Plus is designed for use together with OpenBus™ control boxes.

The MJB5 Plus makes it possible to connect multiple hand controls and attendant controls. It can even be used for charging or to connect the Under Bed Light and 3rd party products.

MJB5 Plus Port Repeater, version 000:

The MJB5 Plus version 000 is used where there is a need for more ports than available in the control box. It is possible to connect multiple MJB5 Plus boxes obtaining unlimited extra connections to the control box.

Usage

Compatibility:	All OpenBus products
Operation temperature:	+5 °C to +40 °C
Storage temperature:	-10 °C to + 50 °C
Relative humidity:	20% to 80% non-condensing
Atmospheric pressure:	700 to 1060 hPa
Operational meters above sea level:	Max. 3000 meters
Latex free:	Yes
Approvals:	IEC60601-1, IEC60601-1-6 ANSI/AAMI ES60601-1 CAN/CSA-22.2 No 60601-1

MJB5 Plus Port repeater usage:

Compatibility: All OpenBus products and CA control boxes.

Modular plug cable, narrow/wide alignment grooves:

Modular plug with wide alignment groove.

To be used with LINAK products. Can be connected to all ports in the MJB5 Plus, both ports with narrow and wide alignment grooves.

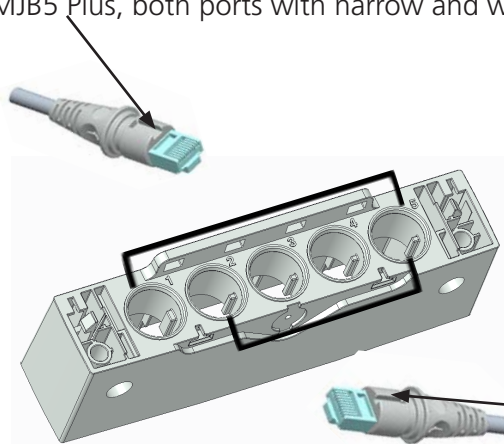

Modular plug with narrow alignment groove.
To be used with 3rd party products.

Can only be connected to ports in the MJB5 Plus with narrow slit. This is to prevent 3rd party products to interfere with the OpenBus™ connections.

MJB5 Plus mounting without bracket

MJB5 Plus can be mounted directly on the application from the MJB5 Plus side or via the top.

It is recommended to use screw type DIN912 M4 for mounting without the bracket.

When mounting, ensure that a screw torque limit of 1.0 Nm is not exceeded.

Mounting from the MJB5 Plus side

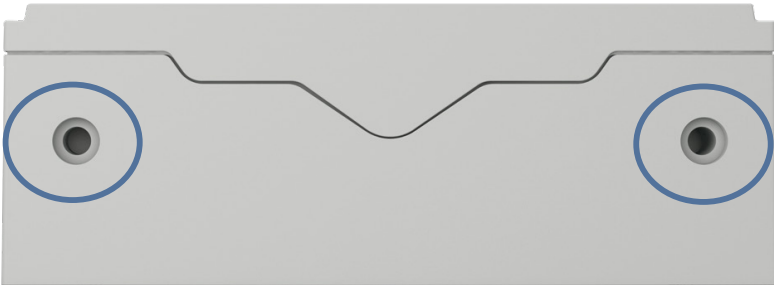

Mounting from the MJB5 Plus top



Unlocking of cable locking mechanism

If a cable needs to be replaced or added, we recommend to open the cable locking mechanism as described below and demonstrated in our video on LINAK.com - MJB5 Plus section brochures and manuals.



Video guide available on www.linak.com



1. Insert a pin or screwdriver with a diameter of 3.5 to 4 mm.



2. Pull downwards until a click sound is heard. Repeat this for the other locking hole.



3. The cable mechanism is now unlocked.

Locking of cable locking mechanism



Video guide available on www.linak.com

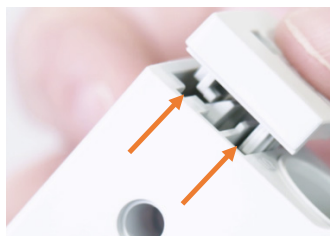

1. Align the locking mechanism with the MJB5 Plus.



2. Press the cable locking mechanism down until you hear a click sound.



3. Slide the mechanism forward until you hear another click sound.



4. MJB5 Plus with a locked cable mechanism.

Multi-flexible mounting bracket for MJB5 Plus - article no. 1015W1010-A

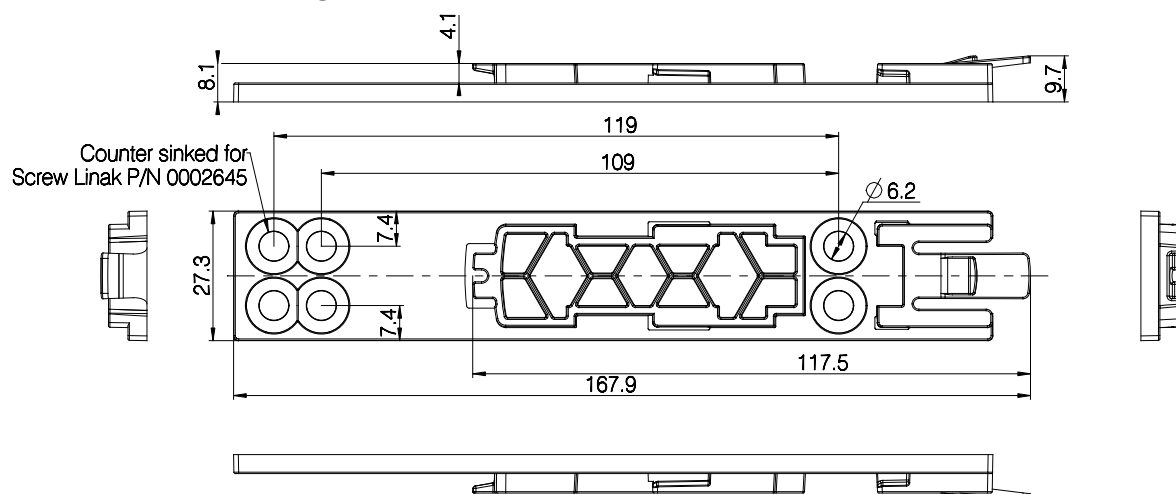

Drawing no.: 0835012

Mount the bracket on the side or the back of the MJB5 Plus.

If it is necessary to dismount the MJB5 Plus from the application, we recommend to use the bracket for mounting.

Use special screws type WN1423 K60x16, ordering no. 0002645.

The screws must be mounted with a torque of maximum 1,0 Nm. The screw head will then be flush with the bracket.

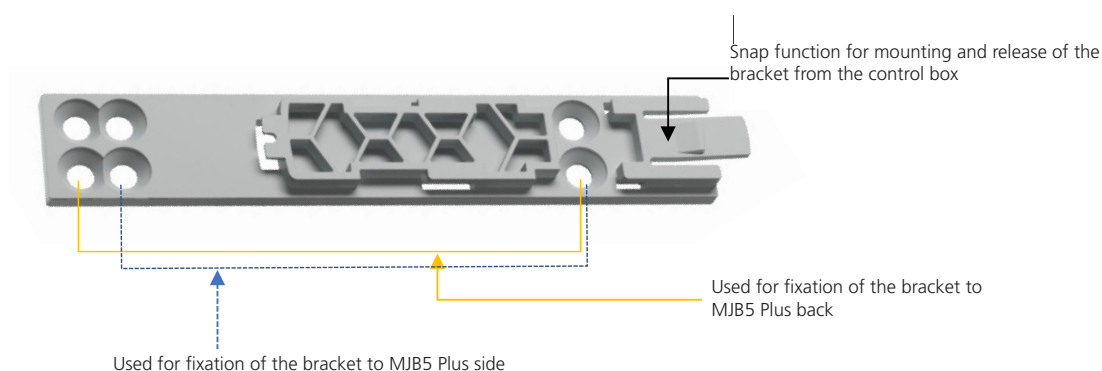

The bracket is very flexible for mounting but we recommend one of the following fixations.

Bracket fixation to the MJB5 Plus back:



Bracket fixation to the MJB5 Plus side:



The MJB5 Plus bracket is for mounting on the CO and CB OpenBus control boxes.

Mounting examples



MJB5 Plus with bracket mounted on the side.
MJB5 Plus mounted on the side of the control box.

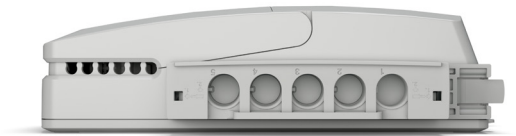
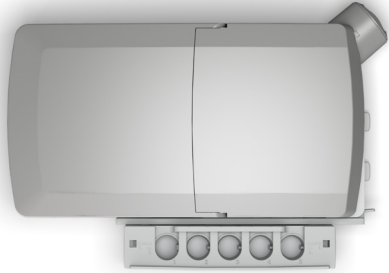

MJB5 Plus with bracket mounted on the back.
MJB5 Plus mounted on the side of the control box.



Recommendations

- The MJB must be mounted on an even surface
- The locking surface must be free of other material
- Always use locking mechanism and O-ring
- Sockets not used must be fitted with blind plugs to ensure the IP degree
- HOT PLUGGING

Removing or adding any OpenBus cables are not allowed when the control box is powered by mains supply!

If needed anyway follow the below procedure:

1. Remove mains and wait 5 sec.
2. Mount or dismount the required cables

If this procedure is NOT followed it may result in a damaged OpenBus driver circuit.

The risk of a damaged circuit increases if the accessory has a high start current (in rush current).

- When using USB cable (0834000) or modular plug cable (0964399) with open end, it is up to the customer to maintain the IP degree.
- Do not use 2 MJB5 Plus variants with same device ID on the OpenBus™.
- This will cause conflicts and the SDT is not able to identify the different products attached.
- Before the final functional test in the production, is it important that the system is re-powered. This is to make sure that all items have been detected on the OpenBus.
- We recommend that the end user makes a regular test procedure, in order to prevent failures and hazardous situations on the system, e.g. squeezed cables. The MJB5 Plus is not able to detect defective 3rd party products.
- LINAK only takes responsibility for LINAK products, not 3rd party products.
- Please pay attention to the "Patient Environment" Clause 3.79 - IEC60601-1.
- There can be a risk of conflict with other OpenBus accessories, such as HB, etc. it is therefore recommended to make a system/bit overview.
- When connecting 3rd party products to LINAK systems, the customer must take necessary precautions against Electrostatic Discharge (ESD).
- Exposure to harmful ESD must be avoided.
- 3rd party products must be designed with the following isolation:
- Minimum 1 MOPP (creepage distance/clearance according to IEC 60601-1).
- Ensure that a screw torque of 1.0 Nm is not exceeded when mounting the MJB5 Plus with or without the bracket.



Modular Junction Box - MJB5 Plus Port SMPS



The modular junction box MJB5 Plus is designed for use together with OpenBus™ control boxes.

The MJB5 Plus makes it possible to connect multiple hand controls and attendant controls. It can even be used for charging or to connect the Under Bed Light and 3rd party products.

MJB5 Plus with Switch Mode Power Supply (SMPS) 5V SMPS, version 502-010

The SMPS is to be used where there is a need for power supply near the bed. For example, to charge electronic devices.

It is also possible to connect a bedside lamp from our 3rd party supplier. This will be connected directly to the MJB5 Plus port 2 via a modular plug. The SMPS indicates with an LED on the hand control whether the power supply is switched on or off.

Usage

Compatibility:	Alle OpenBus products
Operation temperature:	+5 °C to +40 °C
Storage temperature:	-10 °C to +50 °C
Relative humidity:	20% to 80% – non-condensing
Atmospheric pressure:	700 to 1060 hPa
Meters above sea level:	Max. 3000 meters
Latex free:	Yes
Approvals:	IEC60601-1, IEC60601-1-6 ANSI/AAMI ES60601-1 CAN/CSA-22.2 No 60601-1

Standard functionality

Port 1 is to be connected to the OpenBus control box.

The electronic device must be connected to PORT 2. The power on port 2 can be switched on/off via the patient control (key 1) or the attendant control (key 2), the status is indicated on the OpenBus. Switching on/off the power supply is useful, for instance when the SMPS is used together with a bedside lamp. If an error occurs, this is indicated on the OpenBus. As standard, it is switched off.

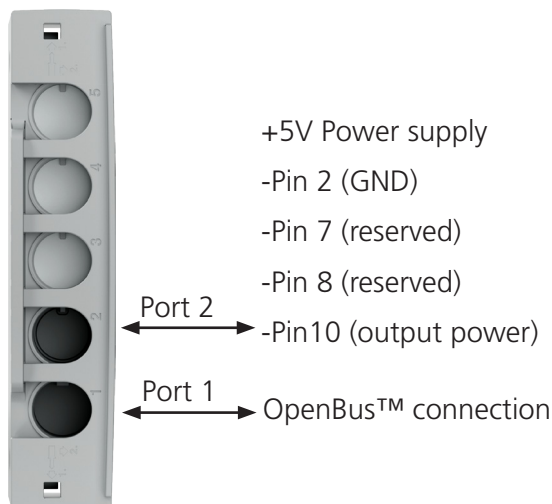

Modular plug cable, narrow/wide alignment grooves

Modular plug with wide alignment groove.

To be used with LINAK products.

Can be connected to all ports in the MJB5 Plus, both ports with narrow and wide alignment grooves.

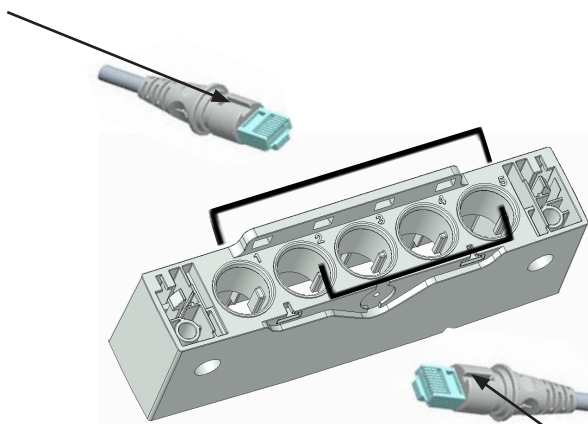

Modular plug with narrow alignment groove.

To be used with 3rd party products.

Can only be connected to ports in the MJB5 Plus with narrow slit. This is to prevent 3rd party products to interfere with the OpenBus™ connections.

MJB5 Plus mounting without bracket

MJB5 Plus can be mounted directly on the application from the MJB5 Plus side or via the top. It is recommended to use screw type DIN912 M4 for mounting without the bracket. When mounting, ensure that a screw torque limit of 1.0 Nm is not exceeded.

Mounting from the MJB5 Plus side

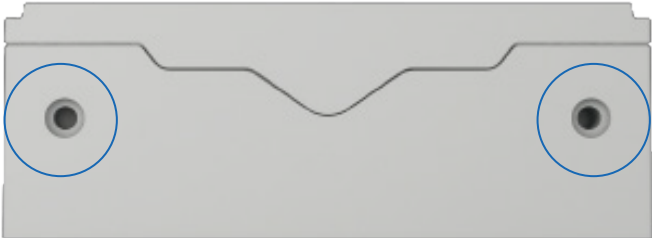

Mounting from the MJB5 Plus top



Unlocking of cable locking mechanism

If a cable needs to be replaced or added, we recommend to open the cable locking mechanism as described below and demonstrated in our video on LINAK.com - MJB5 Plus section brochures and manuals.



Video guide available on www.linak.com



1. Insert a pin or screwdriver with a diameter of 3.5 to 4 mm.



2. Pull downwards until a click sound is heard. Repeat this for the other locking hole.



3. The cable mechanism is now unlocked.

Locking of cable locking mechanism



Video guide available on www.linak.com

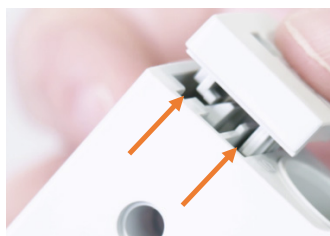

1. Align the locking mechanism with the MJB5 Plus.



2. Press the cable locking mechanism down until you hear a click sound.



3. Slide the mechanism forward until you hear another click sound.



4. MJB5 Plus with a locked cable mechanism.

Multi-flexible mounting bracket for MJB5 Plus - article no. 1015W1010-A

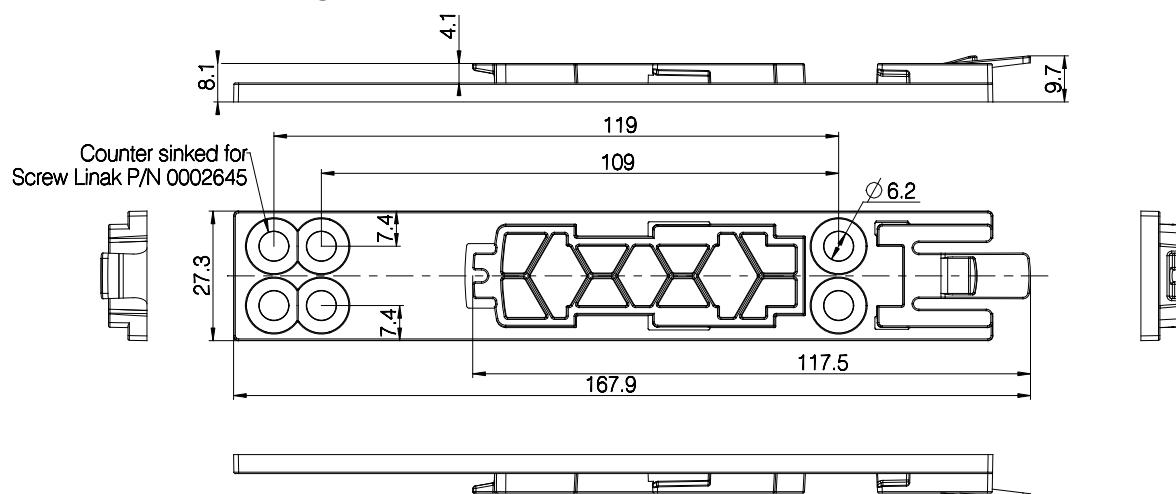

Drawing no.: 0835012

Mount the bracket on the side or the back of the MJB5 Plus.

If it is necessary to dismantle the MJB5 Plus from the application, we recommend to use the bracket for mounting.

Use special screws type WN1423 K60x16, ordering no. 0002645.

The screws must be mounted with a torque of maximum 1,0 Nm. The screw head will then be flush with the bracket.

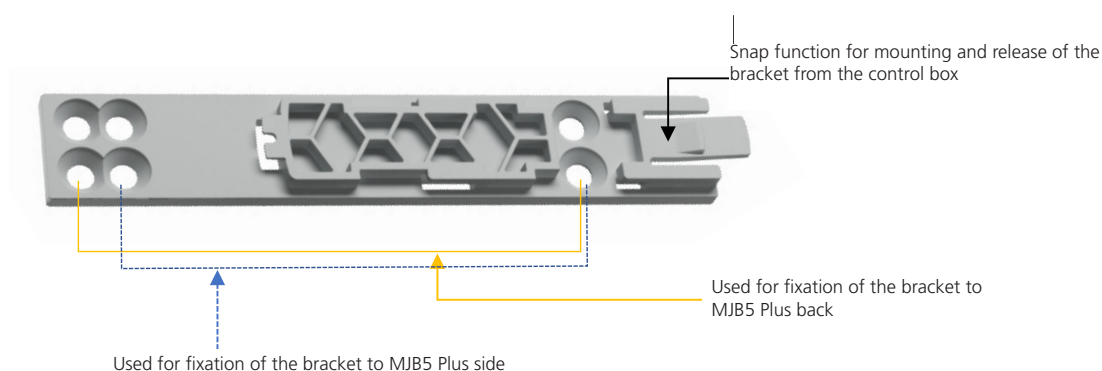

The bracket is very flexible for mounting but we recommend one of the following fixations.

Bracket fixation to the MJB5 Plus back:



Bracket fixation to the MJB5 Plus side:

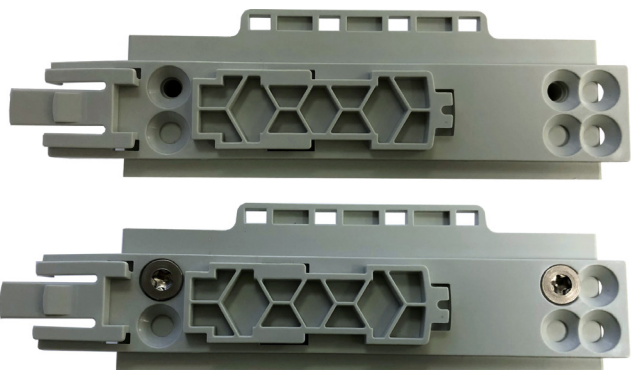

The MJB5 Plus bracket is for mounting on the CO and CB OpenBus control boxes.

Mounting examples



MJB5 Plus with bracket mounted on the side.
MJB5 Plus mounted on the side of the control box.

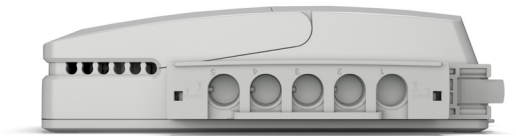
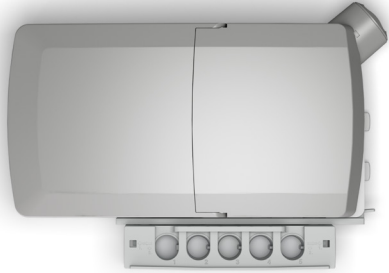

MJB5 Plus with bracket mounted on the back.
MJB5 Plus mounted on the side of the control box.



Recommendations

- The MJB must be mounted on an even surface
- The locking surface must be free of other material
- Always use locking mechanism and O-ring
- Sockets not used must be fitted with blind plugs to ensure the IP degree
- HOT PLUGGING

Removing or adding any OpenBus cables are not allowed when the control box is powered by mains supply!

If needed anyway follow the below procedure:

1. Remove mains and wait 5 sec.
2. Mount or dismount the required cables

If this procedure is NOT followed it may result in a damaged OpenBus driver circuit.

The risk of a damaged circuit increases if the accessory has a high start current (in rush current).

- When using USB cable (0834000) or modular plug cable (0964399) with open end, it is up to the customer to maintain the IP degree.
- Do not use 2 MJB5 Plus variants with same device ID on the OpenBus™.
- This will cause conflicts and the SDT is not able to identify the different products attached.
- Before the final functional test in the production, is it important that the system is re-powered. This is to make sure that all items have been detected on the OpenBus.
- We recommend that the end user makes a regular test procedure, in order to prevent failures and hazardous situations on the system, e.g. squeezed cables. The MJB5 Plus is not able to detect defective 3rd party products.
- LINAK only takes responsibility for LINAK products, not 3rd party products.
- Please pay attention to the "Patient Environment" Clause 3.79 - IEC60601-1.
- There can be a risk of conflict with other OpenBus accessories, such as HB, etc. it is therefore recommended to make a system/bit overview.
- When connecting 3rd party products to LINAK systems, the customer must take necessary precautions against Electrostatic Discharge (ESD).
- Exposure to harmful ESD must be avoided.
- 3rd party products must be designed with the following isolation:
- Minimum 1 MOPP (creepage distance/clearance according to IEC 60601-1).
- Ensure that a screw torque of 1.0 Nm is not exceeded when mounting the MJB5 Plus with or without the bracket.





MJB5 Plus SMPS Special Recommendations

- The USB cable 0834000 is not medically approved.
- The MJB5 Plus with SMPS is as standard defined as a 150mA (4W ver.) type. This means that when the SMPS is delivering max. power on port 2, the remaining power on the V permanent is maximum 50 mA. This can have influence when other accessories are connected to the system. The output power can drop when driving the bed with full load.
- When the SMPS is being used on a system with battery, the output power will follow the power-down mode of the control box, see table:

OpenBus control box power mode		SMPS 4W output power
On mains		4W
On battery	Power down	No power
	"Wake up"	2W



Modular Junction Box - MJB5 Plus Gateway



The modular junction box MJB5 Plus is designed for use together with OpenBus™ control boxes.

The MJB5 Plus makes it possible to connect multiple hand controls and attendant controls. It can even be used for charging or to connect the Under Bed Light and 3rd party products.

MJB5 Plus versions 504-010 & 504-020:

The MJB5 Plus is a simple gateway interface which can connect switch input notifications from the hospital or nursing home infrastructure such as service/nurse call systems.

Please note that notifications are only to be used as service information and not for emergency issues.

Usage

Compatibility:	Alle OpenBus products
Operation temperature:	+5 °C to +40 °C
Storage temperature:	-10 °C to +50 °C
Relative humidity:	20% to 80% – non-condensing
Atmospheric pressure:	700 to 1060 hPa
Meters above sea level:	Max. 3000 meters
Latex free:	Yes
Approvals:	IEC60601-1 ANSI/AAMI ES60601-1 CAN/CSA-22.2 No 60601-1

MJB5 Plus Gateway Usage

Contact rating:	Maximum continuous current: 1A Maximum switching voltage: 48VDC Maximum switching capacity: 24VA Contact resistance: <100 mΩ
Current consumption	V bus 8V: 9 mA V permanent 40V: 14 mA

Standard functionality

The MJB5 Plus Gateway consists of two relays, which are connected through port 5 on the MJB5 Plus. This can be done with the special cable 0964140 (modular plug - open end)

There are as standard 2 configurations, 504-010 and 504-020, see description on the next pages.

Relay 1: NC (normally closed) = Pin 2 + Pin 1/NO (normally open) = Pin 2 + Pin 3

Relay 2: NC (normally closed) = Pin 5 + Pin 4/NO (normally open) = Pin 5 + Pin 6

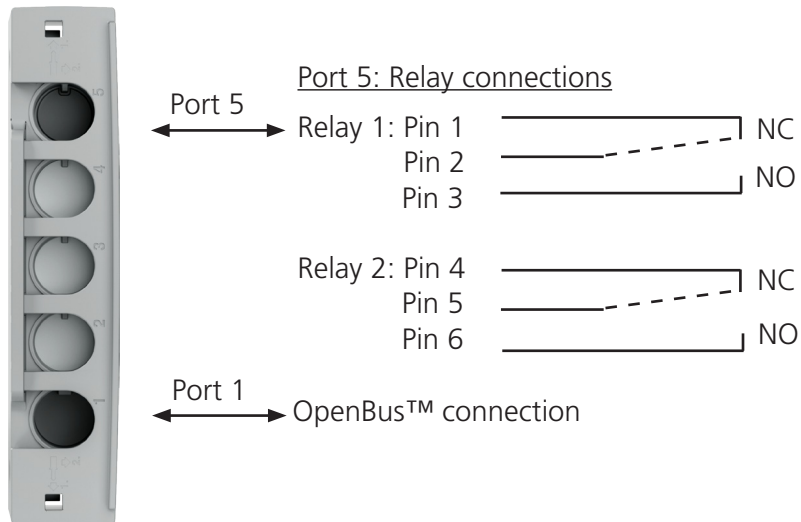

Relay 1

Relay 1 is NO when connected to mains and NC when no mains, this means the relay is “active”, when connected to mains (closed loop). The closed loop principal is to ensure that a notification is sent if power is missing on the bed. When mains is disconnected (power is missing), the relay will go from NO to NC which will automatically result in a notification (status indicator) on the OpenBus.

Relay 1 can be activated via the patient control (Key1/Key4) or the attendant control (Key2 / Key3). When a key is activated, the relay will switch state from NO to NC for 2 seconds. After 2 seconds the relay will automatically change state from NC to NO.

The status of the relay is indicated on the OpenBus and can be used for switching on an LED.

Relay 1		
OpenBus control box power mode	Notification level	Relay state
Mains unplugged, the control box is in power-down or the OpenBus is not running (Clock/data is missing)	Notification	NC*
On mains or battery at “wake up”	Bed notification**	NC
	No notification	NO

Relay 2

Relay 2 is as default NC, with or without mains, (open loop).

Relay 2 can be activated via the patient control (Key 1) or the attendant control (Key 2 / Key 3).

When the relay is activated, it will switch from NC to NO for 2 seconds. After 2 seconds the relay will automatically change state from NO to NC.

The status of the relay is indicated on the OpenBus™ and can be used for switching on an LED.

By using the variant 504-020 will relay 2 be controlled by the MJB5 Plus variant 505/506 with switch input.

Notification 1 = Switch input S2 / notification 2 = Switch input S1

When using this combination, is it important to have the MJB5 Plus 505/506 connected to the system all the time. If it is not connected, the Gateway MJB5 Plus will see it as a notification and the relay will be activated. The Gateway MJB5 Plus is “scanning” the OpenBus system. every minute for a notification.

Relay 2		
CB or OpenBus control box power mode	Notification level	Relay state
Mains unplugged or the control box is in power-down	No notification	NC
On mains or battery at “wake up”	Bed notification**	NO
	No notification	NC

* When mains is unplugged or CB or the OpenBus control box is in power-down, the relay will shift to NC state and generate a notification.

** Notification generated by nurse call or bed notifications.



Example of closed loop:

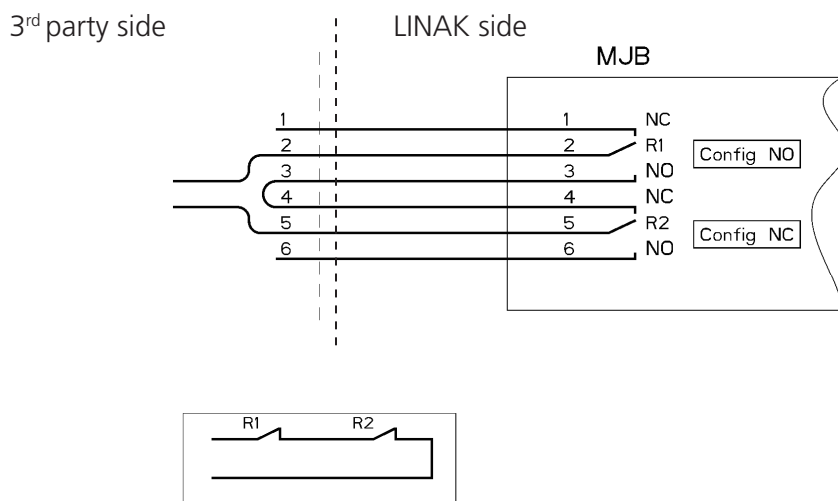

Example of open loop:

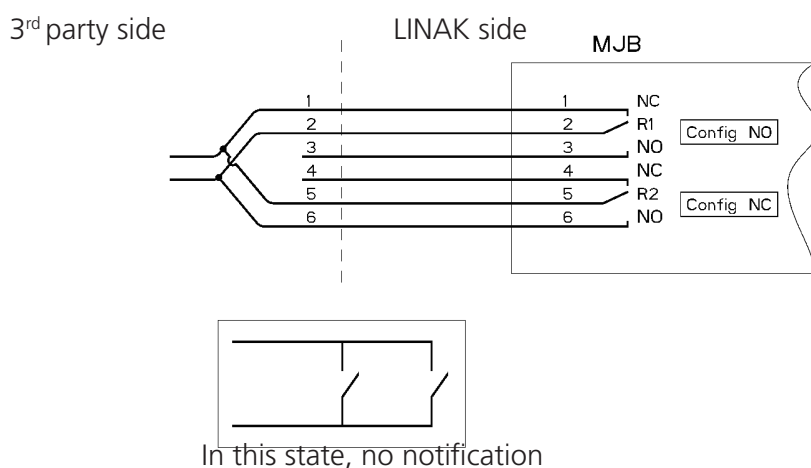

Modular plug cable, narrow/wide alignment grooves

Modular plug with wide alignment groove.

To be used with LINAK products.

Can be connected to all ports in the MJB5 Plus, both ports with narrow and wide alignment grooves.

with narrow and wide alignment grooves.

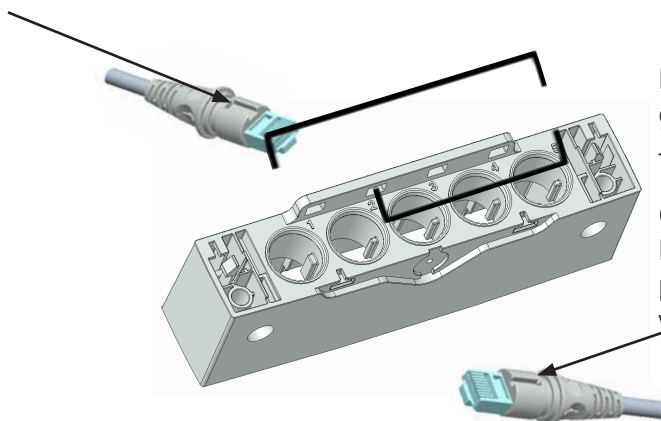

Modular plug with narrow alignment groove.

To be used with 3rd party products.

Can only be connected to ports in the MJB5 Plus with narrow slit. This is to prevent 3rd party products to interfere with the OpenBus™ connections.

MJB5 Plus mounting without bracket

MJB5 Plus can be mounted directly on the application from the MJB5 Plus side or via the top.

It is recommended to use screw type DIN912 M4 for mounting without the bracket.

When mounting, ensure that a screw torque limit of 1.0 Nm is not exceeded.

Mounting from the MJB5 Plus side



Mounting from the MJB5 Plus top



Unlocking of cable locking mechanism

If a cable needs to be replaced or added, we recommend to open the cable locking mechanism as described below and demonstrated in our video on LINAK.com - MJB5 Plus section brochures and manuals.



Video guide available on www.linak.com



1. Insert a pin or screwdriver with a diameter of 3.5 to 4 mm.



2. Pull downwards until a click sound is heard. Repeat this for the other locking hole.



3. The cable mechanism is now unlocked.

Locking of cable locking mechanism



Video guide available on www.linak.com

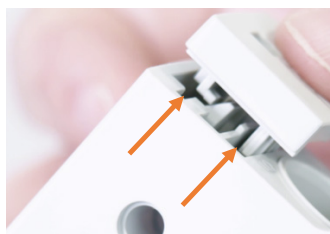

1. Align the locking mechanism with the MJB5 Plus.



2. Press the cable locking mechanism down until you hear a click sound.



3. Slide the mechanism forward until you hear another click sound.



4. MJB5 Plus with a locked cable mechanism.

Multi-flexible mounting bracket for MJB5 Plus - article no. 1015W1010-A

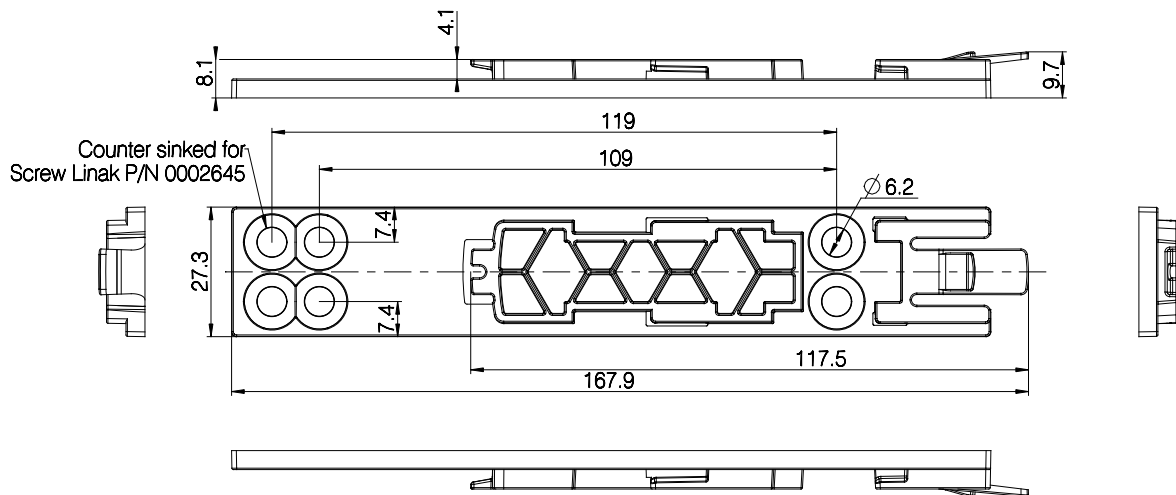

Drawing no.: 0835012

Mount the bracket on the side or the back of the MJB5 Plus.

If it is necessary to dismount the MJB5 Plus from the application, we recommend to use the bracket for mounting.

Use special screws type WN1423 K60x16, ordering no. 0002645.

The screws must be mounted with a torque of maximum 1,0 Nm. The screw head will then be flush with the bracket.

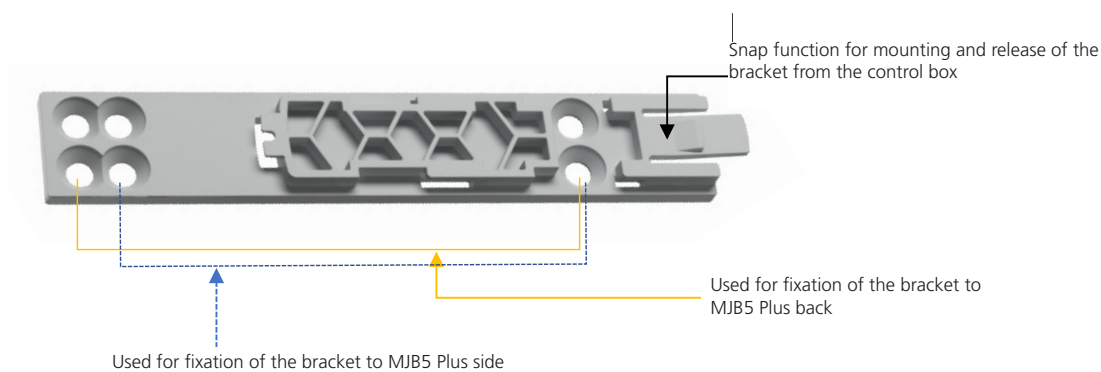

The bracket is very flexible for mounting but we recommend one of the following fixations.

Bracket fixation to the MJB5 Plus back:



Bracket fixation to the MJB5 Plus side:

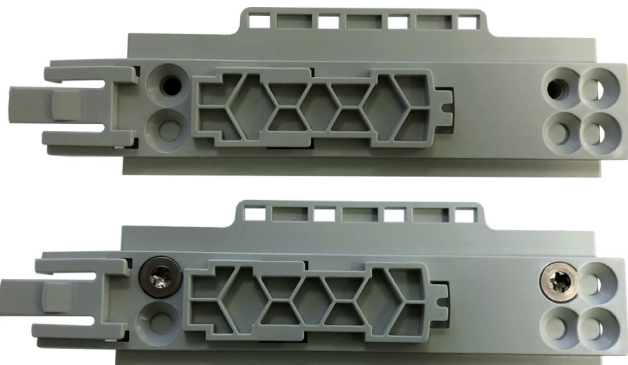

The MJB5 Plus bracket is for mounting on the CO and CB OpenBus control boxes.

Mounting examples

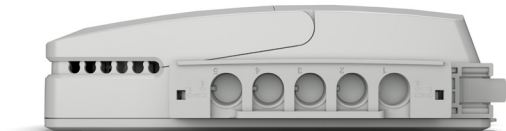
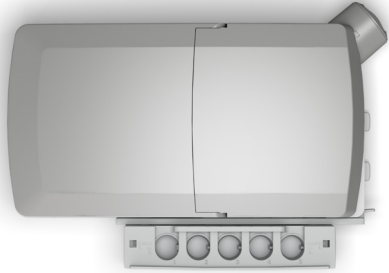

MJB5 Plus with bracket mounted on the back.

MJB5 Plus mounted on the side of the control box.



Recommendations

- The MJB must be mounted on an even surface
- The locking surface must be free of other material
- Always use locking mechanism and O-ring
- Sockets not used must be fitted with blind plugs to ensure the IP degree
- HOT PLUGGING

Removing or adding any OpenBus cables are not allowed when the control box is powered by mains supply!

If needed anyway follow the below procedure:

1. Remove mains and wait 5 sec.
2. Mount or dismount the required cables

If this procedure is NOT followed it may result in a damaged OpenBus driver circuit.

The risk of a damaged circuit increases if the accessory has a high start current (in rush current).

- When using USB cable (0834000) or modular plug cable (0964399) with open end, it is up to the customer to maintain the IP degree.
- Do not use 2 MJB5 Plus variants with same device ID on the OpenBus™.
- This will cause conflicts and the SDT is not able to identify the different products attached.
- Before the final functional test in the production, is it important that the system is re-powered. This is to make sure that all items have been detected on the OpenBus.
- We recommend that the end user makes a regular test procedure, in order to prevent failures and hazardous situations on the system, e.g. squeezed cables. The MJB5 Plus is not able to detect defective 3rd party products.
- LINAK only takes responsibility for LINAK products, not 3rd party products.
- Please pay attention to the "Patient Environment" Clause 3.79 - IEC60601-1.
- There can be a risk of conflict with other OpenBus accessories, such as HB, etc. it is therefore recommended to make a system/bit overview.
- When connecting 3rd party products to LINAK systems, the customer must take necessary precautions against Electrostatic Discharge (ESD).
- Exposure to harmful ESD must be avoided.
- 3rd party products must be designed with the following isolation:
 - Minimum 1 MOPP (creepage distance/clearance according to IEC 60601-1).
 - Ensure that a screw torque of 1.0 Nm is not exceeded when mounting the MJB5 Plus with or without the bracket.





MJB5 Plus Gateway Special Recommendations

- If the MJB5 Plus Gateway is used as open loop, there is a risk of not sending a notification, when no mains is connected. The MJB5 Plus Gateway will only send a notification if mains is missing, when using a closed loop (see functionality description.)
- When the Gateway is being used on a system with battery, the gateway functionality will follow the power-down mode of the control box, see table:

OpenBus control box power mode		Gateway
On mains		function ok
On battery	power down	No function
	"wake up"	Function ok

- The MJB5 Plus Gateway is not to be used as safety, it is only to be used as a guided system.
- It is important to test the specified notification is working in the correct way, before sending the system to the end user.



Modular Junction Box - MJB5 Plus UBL (int.)



The modular junction box MJB5 Plus is designed for use together with OpenBus™ control boxes.

The MJB5 Plus makes it possible to connect multiple hand controls and attendant controls. It can even be used for charging or to connect the Under Bed Light and 3rd party products.

MJB5 Plus versions 505-010 and 505-020

The MJB5 Plus is a modular junction box with 3 different options, Under Bed Light (UBL) and 2 different switch inputs, S1 and S2, which can be used for an external switch.

UBL: The MJB5 Plus with UBL gives a guiding light when the patient leaves the bed and makes it easy to find the way back to bed at night without disturbing other patients. The MJB5 Plus has an LED integrated in the MJB5 Plus housing which makes it easy to use.

External Switch (S1/S2): It is possible for the customer to connect a switch directly to the MJB5 Plus. This can be used with a customised switch or control.

Usage

Compatibility:	Alle OpenBus products
Operation temperature:	+5 °C to +40 °C
Storage temperature:	-10 °C to +50 °C
Relative humidity:	20% to 80% – non-condensing
Atmospheric pressure:	700 to 1060 hPa
Meters above sea level:	Max. 3000 meters
Latex free:	Yes
Approvals:	IEC60601-1 ANSI/AAMI ES60601-1 CAN/CSA-22.2 No 60601-1

Standard functionality

UBL: The UBL LED can be switched on and off via the patient control (Key 1) or the attendant control (Key 2).

External Switch (S1/S2): The external switch is connected to S1: Pin 2 & 8/S2: Pin 2 and 9 on Port 2, Port 4 or Port 5.

The Switch input functionality can be enabled/disabled via the attendant control. The enable/disable status (switch status) is indicated on the OpenBus.

The switch input functionality is as standard to be used with a NO switch. When the switch is activated (NC), a notification is sent on the OpenBus (switch notification).

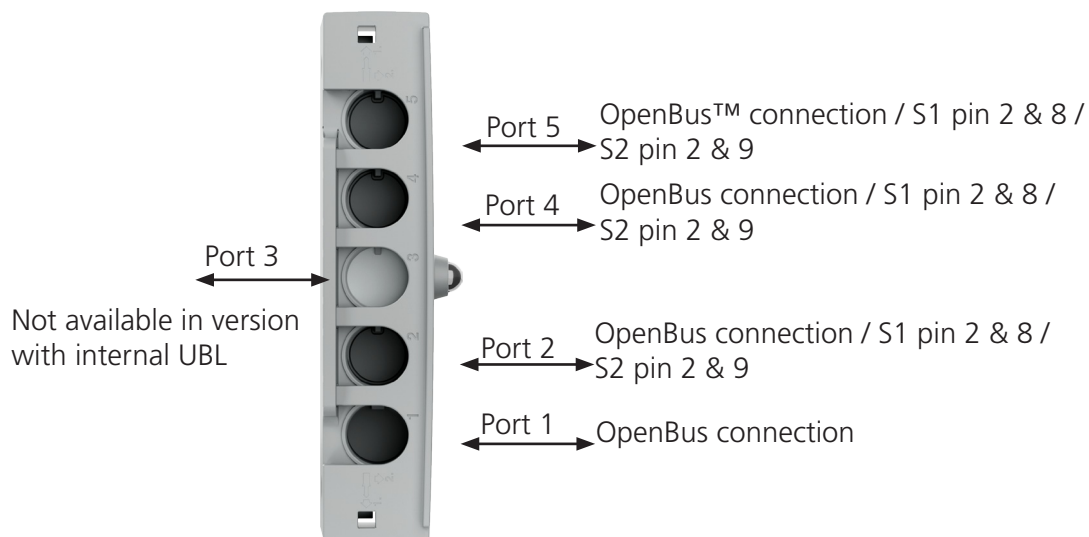

MJB5 Plus mounting without bracket

MJB5 Plus can be mounted directly on the application from the MJB5 Plus side or via the top.

It is recommended to use screw type DIN912 M4 for mounting without the bracket.

When mounting, ensure that a screw torque limit of 1.0 Nm is not exceeded.

Mounting from the MJB5 Plus side



Mounting from the MJB5 Plus top



Unlocking of cable locking mechanism

If a cable needs to be replaced or added, we recommend to open the cable locking mechanism as described below and demonstrated in our video on LINAK.com - MJB5 Plus section brochures and manuals.



Video guide available on www.linak.com



1. Insert a pin or screwdriver with a diameter of 3.5 to 4 mm.



2. Pull downwards until a click sound is heard. Repeat this for the other locking hole.



3. The cable mechanism is now unlocked.

Locking of cable locking mechanism



Video guide available on www.linak.com

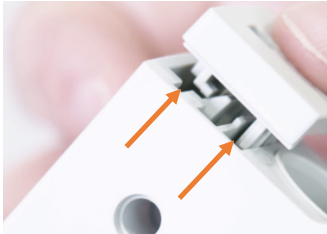

1. Align the locking mechanism with the MJB5 Plus.



2. Press the cable locking mechanism down until you hear a click sound.



3. Slide the mechanism forward until you hear another click sound.



4. MJB5 Plus with a locked cable mechanism.

Modular plug with wide alignment groove.

To be used with LINAK products.

Can be connected to all ports in the MJB5 Plus, both ports with narrow and wide alignment grooves.

with narrow and wide alignment grooves.

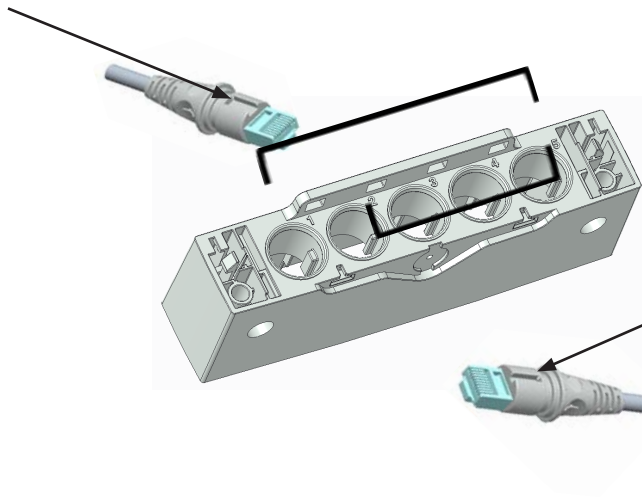

Modular plug with narrow alignment groove.

To be used with 3rd party products.

Can only be connected to ports in the MJB5 Plus with narrow slit. This is to prevent 3rd party products to interfere with the OpenBus™ connections.

Open-end cable

0964399: Open end cable for Under Bed Light internal and external and switch input. Length 1500 mm.

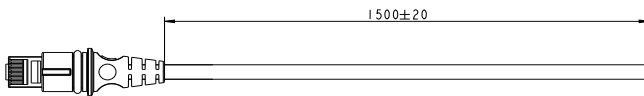

Multi-flexible mounting bracket for MJB5 Plus - article no. 1015W1010-A

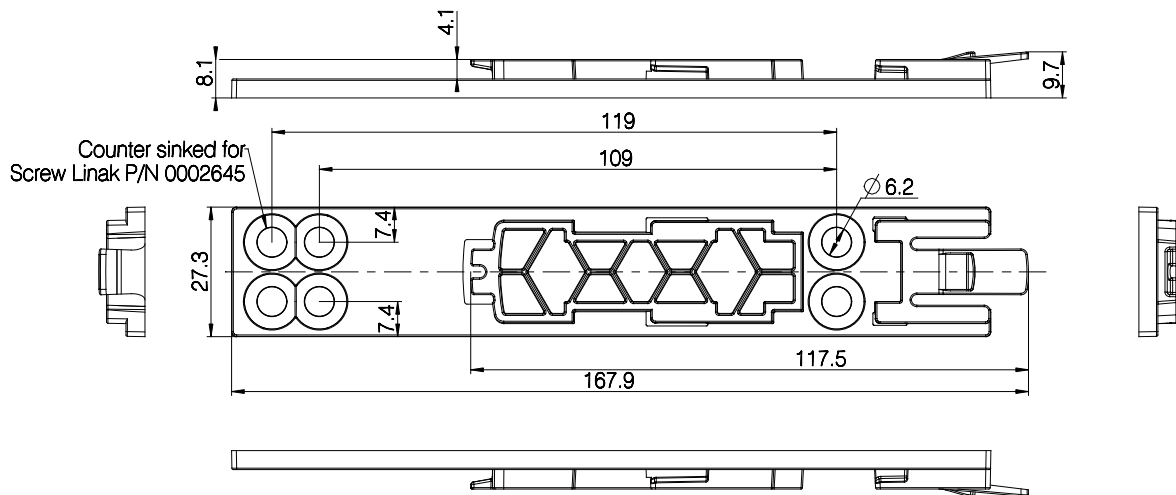

Drawing no.: 0835012

Mount the bracket on the side or the back of the MJB5 Plus.

If it is necessary to dismount the MJB5 Plus from the application, we recommend to use the bracket for mounting.

Use special screws type WN1423 K60x16, ordering no. 0002645.

The screws must be mounted with a torque of maximum 1,0 Nm. The screw head will then be flush with the bracket.

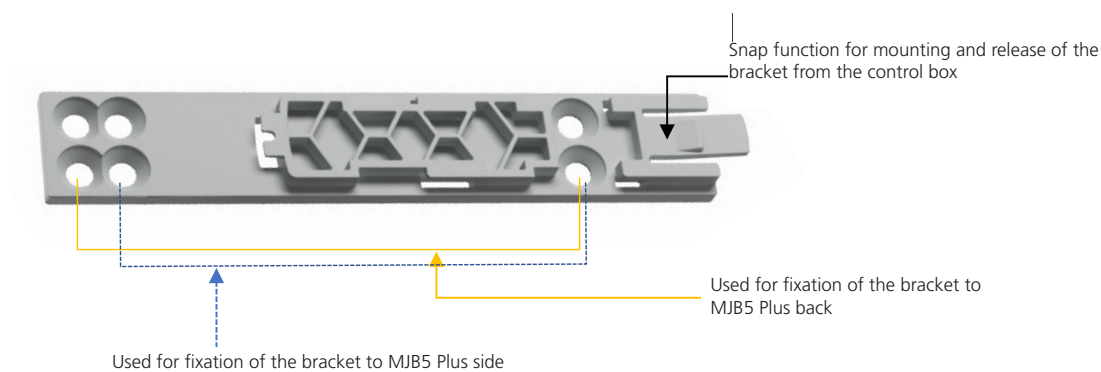

The bracket is very flexible for mounting but we recommend one of the following fixations.

Bracket fixation to the MJB5 Plus back:



Bracket fixation to the MJB5 Plus side:



The MJB5 Plus bracket is for mounting on the CO and CB OpenBus control boxes.

Mounting examples

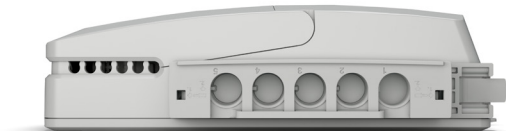
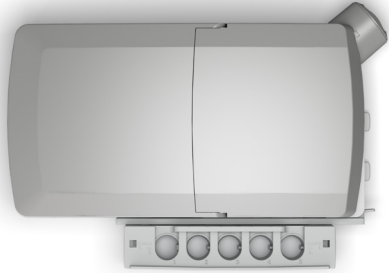
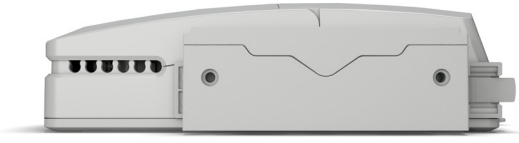

MJB5 Plus with bracket mounted on the back.

MJB5 Plus mounted on the side of the control box.



Recommendations

- The MJB must be mounted on an even surface
- The locking surface must be free of other material
- Always use locking mechanism and O-ring
- Sockets not used must be fitted with blind plugs to ensure the IP degree
- HOT PLUGGING

Removing or adding any OpenBus cables are not allowed when the control box is powered by mains supply!

If needed anyway follow the below procedure:

1. Remove mains and wait 5 sec.
2. Mount or dismount the required cables

If this procedure is NOT followed it may result in a damaged OpenBus driver circuit.

The risk of a damaged circuit increases if the accessory has a high start current (in rush current).

- When using USB cable (0834000) or modular plug cable (0964399) with open end, it is up to the customer to maintain the IP degree.
- Do not use 2 MJB5 Plus variants with same device ID on the OpenBus™.
- This will cause conflicts and the SDT is not able to identify the different products attached.
- Before the final functional test in the production, is it important that the system is re-powered. This is to make sure that all items have been detected on the OpenBus.
- We recommend that the end user makes a regular test procedure, in order to prevent failures and hazardous situations on the system, e.g. squeezed cables. The MJB5 Plus is not able to detect defective 3rd party products.
- LINAK only takes responsibility for LINAK products, not 3rd party products.
- Please pay attention to the "Patient Environment" Clause 3.79 - IEC60601-1.
- There can be a risk of conflict with other OpenBus accessories, such as HB, etc. it is therefore recommended to make a system/bit overview.
- When connecting 3rd party products to LINAK systems, the customer must take necessary precautions against Electrostatic Discharge (ESD).
- Exposure to harmful ESD must be avoided.
- 3rd party products must be designed with the following isolation:
 - Minimum 1 MOPP (creepage distance/clearance according to IEC 60601-1).
 - Ensure that a screw torque of 1.0 Nm is not exceeded when mounting the MJB5 Plus with or without the bracket.





MJB5 Plus UBL (int.) Special Recommendations

- When the MJB5 Plus with UBL, and switch input is being used on a system with battery, the functionality will follow the power-down mode of the control box, see table:

OpenBus control box power mode		MJB5 Plus with UBL and switch
On mains		function ok
On battery	power down	No function
	"wake up"	Function ok



Modular Junction Box - MJB5 Plus Switch Input



The modular junction box MJB5 Plus is designed for use together with OpenBus™ control boxes.

The MJB5 Plus makes it possible to connect multiple hand controls and attendant controls. It can even be used for charging or to connect the Under Bed Light and 3rd party products.

MJB5 Plus versions 506-010 and 506-020

The MJB5 Plus is a modular junction box with two switch inputs, S1 and S2, which can be used for an external switch.

External Switch (S1/S2): It is possible for the customer to connect a switch directly to the MJB5 Plus. It can be used with a customised switch or control.

Usage

Compatibility:	Alle OpenBus products
Operation temperature:	+5 °C to +40 °C
Storage temperature:	-10 °C to +50 °C
Relative humidity:	20% to 80% – non-condensing
Atmospheric pressure:	700 to 1060 hPa
Meters above sea level:	Max. 3000 meters
Latex free:	Yes
Approvals:	IEC60601-1 ANSI/AAMI ES60601-1 CAN/CSA-22.2 No 60601-1

Standard functionality

Port 5

The output can be switched on and off via the patient control (Key1) or the attendant control (Key2).

External Switch (S1/S2): The external switch is connected to S1: Pin 2 & 8/S2: Pin 2 and 9 on Port 2, Port 4 or Port 5.

The Switch input functionality can be enabled/disabled via the attendant control for instance to switch on/off a light. The enable/disable status (switch status) is indicated on the OpenBus.

The switch input functionality is as standard to be used with a NO switch. When the switch is activated (NC), a notification is sent on the OpenBus (switch notification).

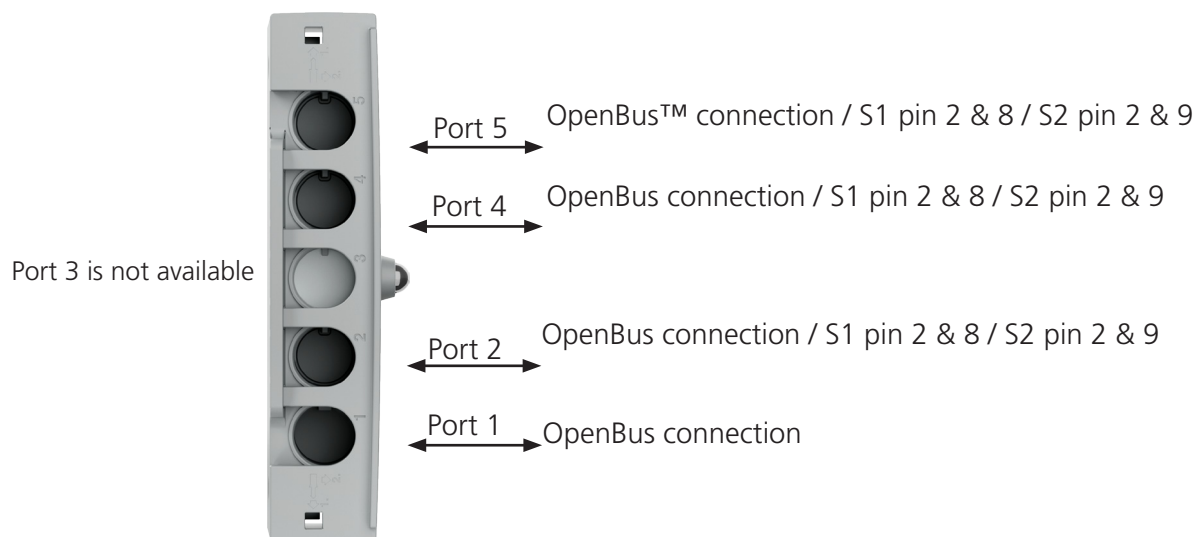

MJB5 Plus mounting without bracket

MJB5 Plus can be mounted directly on the application from the MJB5 Plus side or via the top. It is recommended to use screw type DIN912 M4 for mounting without the bracket. When mounting, ensure that a screw torque limit of 1.0 Nm is not exceeded.

Mounting from the MJB5 Plus side

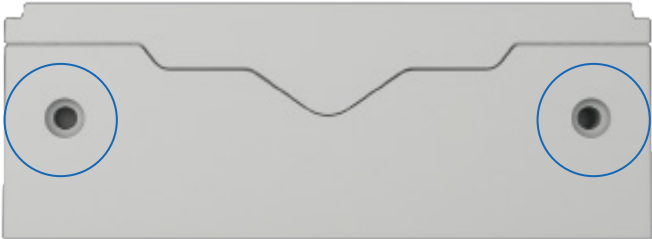

Mounting from the MJB5 Plus top



Unlocking of cable locking mechanism

If a cable needs to be replaced or added, we recommend to open the cable locking mechanism as described below and demonstrated in our video on LINAK.com - MJB5 Plus section brochures and manuals.



Video guide available on www.linak.com



1. Insert a pin or screwdriver with a diameter of 3.5 to 4 mm.



2. Pull downwards until a click sound is heard. Repeat this for the other locking hole.



3. The cable mechanism is now unlocked.

Locking of cable locking mechanism



Video guide available on www.linak.com

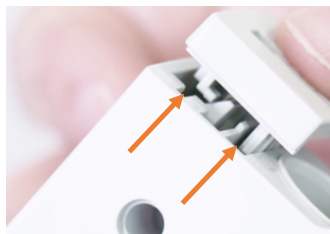

1. Align the locking mechanism with the MJB5 Plus.



2. Press the cable locking mechanism down until you hear a click sound.



3. Slide the mechanism forward until you hear another click sound.



4. MJB5 Plus with a locked cable mechanism.

Under Bed Light cable

0964135: Under Bed Light cable, Length 2500 mm. Please use metal screws for mounting.

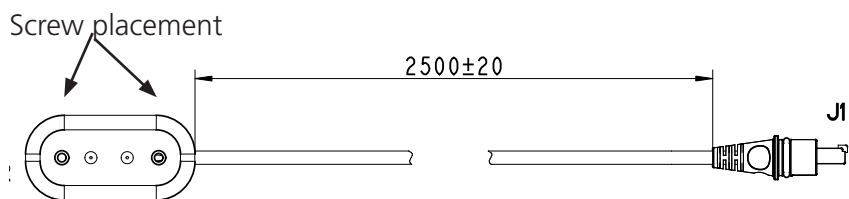

Modular plug with wide alignment groove.

To be used with LINAK products.
Can be connected to all ports in the MJB5 Plus, both ports with narrow and wide alignment grooves.

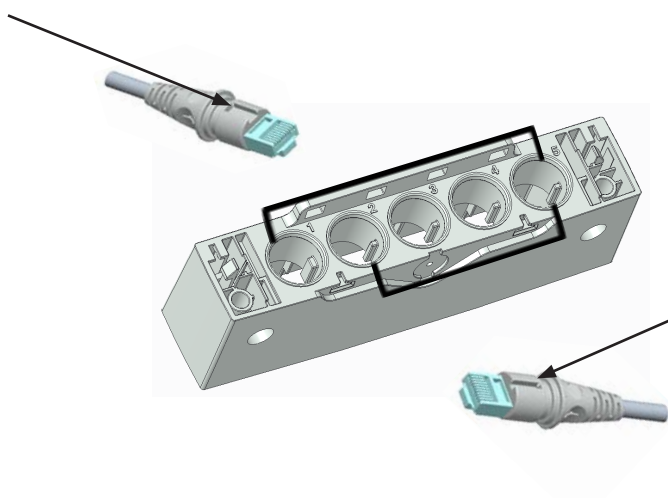

Modular plug with narrow alignment groove.

To be used with 3rd party products.
Can only be connected to ports in the MJB5 Plus with narrow slit. This is to prevent 3rd party products to interfere with the OpenBus™ connections.

Open-end cable

0964399: Open end cable for Under Bed Light internal and external and switch input. Length 1500 mm.

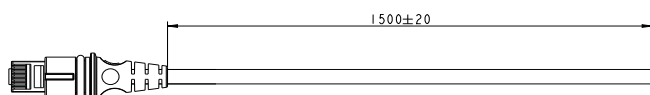

Multi-flexible mounting bracket for MJB5 Plus - article no. 1015W1010-A

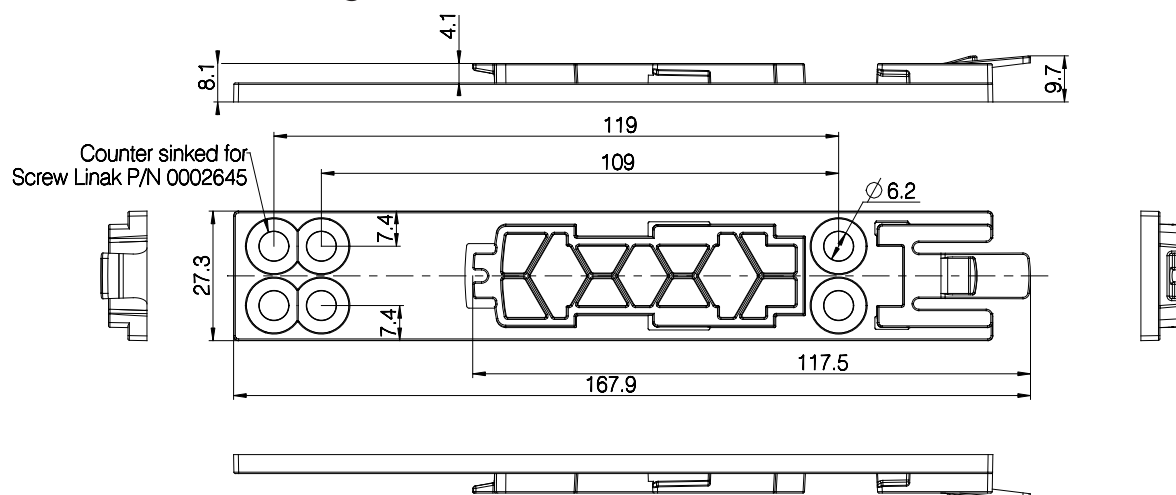

Drawing no.: 0835012

Mount the bracket on the side or the back of the MJB5 Plus.

If it is necessary to dismount the MJB5 Plus from the application, we recommend to use the bracket for mounting.

Use special screws type WN1423 K60x16, ordering no. 0002645.

The screws must be mounted with a torque of maximum 1,0 Nm. The screw head will then be flush with the bracket.

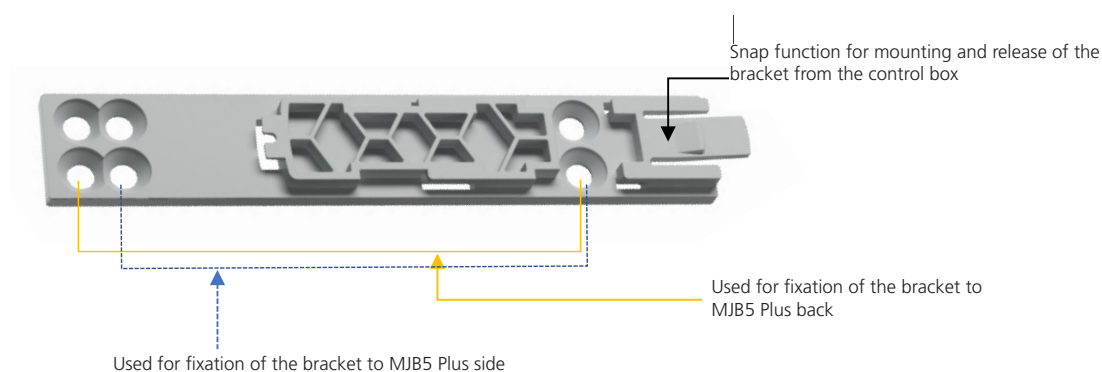

The bracket is very flexible for mounting but we recommend one of the following fixations.

Bracket fixation to the MJB5 Plus back:



Bracket fixation to the MJB5 Plus side:

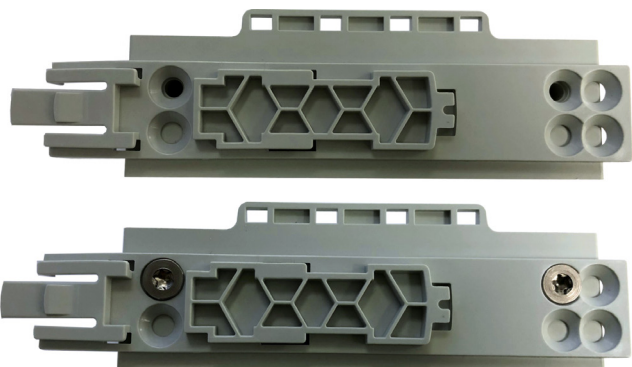

The MJB5 Plus bracket is for mounting on the CO and CB OpenBus control boxes.

Mounting examples

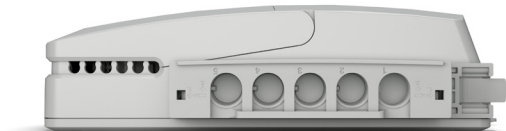
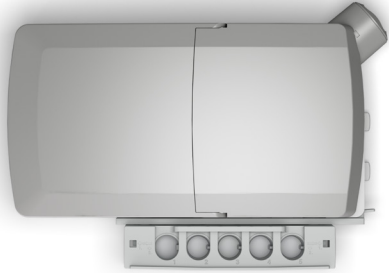
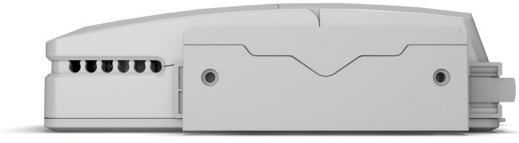

MJB5 Plus with bracket mounted on the back.

MJB5 Plus mounted on the side of the control box.



Recommendations

- The MJB must be mounted on an even surface
- The locking surface must be free of other material
- Always use locking mechanism and O-ring
- Sockets not used must be fitted with blind plugs to ensure the IP degree
- HOT PLUGGING

Removing or adding any OpenBus cables are not allowed when the control box is powered by mains supply!

If needed anyway follow the below procedure:

1. Remove mains and wait 5 sec.
2. Mount or dismount the required cables

If this procedure is NOT followed it may result in a damaged OpenBus driver circuit.

The risk of a damaged circuit increases if the accessory has a high start current (in rush current).

- When using USB cable (0834000) or modular plug cable (0964399) with open end, it is up to the customer to maintain the IP degree.
- Do not use 2 MJB5 Plus variants with same device ID on the OpenBus™.
- This will cause conflicts and the SDT is not able to identify the different products attached.
- Before the final functional test in the production, is it important that the system is re-powered. This is to make sure that all items have been detected on the OpenBus.
- We recommend that the end user makes a regular test procedure, in order to prevent failures and hazardous situations on the system, e.g. squeezed cables. The MJB5 Plus is not able to detect defective 3rd party products.
- LINAK only takes responsibility for LINAK products, not 3rd party products.
- Please pay attention to the "Patient Environment" Clause 3.79 - IEC60601-1.
- There can be a risk of conflict with other OpenBus accessories, such as HB, etc. it is therefore recommended to make a system/bit overview.
- When connecting 3rd party products to LINAK systems, the customer must take necessary precautions against Electrostatic Discharge (ESD).
- Exposure to harmful ESD must be avoided.
- 3rd party products must be designed with the following isolation:
 - Minimum 1 MOPP (creepage distance/clearance according to IEC 60601-1).
 - Ensure that a screw torque of 1.0 Nm is not exceeded when mounting the MJB5 Plus with or without the bracket.





MJB5 Plus UBL (ext.) Special Recommendations

- The LED end of the UBL cable (0964135) must be mounted on the bed with metal screws, in order to maintain ESD protection.
- When the MJB5 Plus with UBL, switch input is being used on a system with battery, the functionality will follow the power-down mode of the control box, see table:

OpenBus control box power mode		MJB5 Plus with UBL and switch
On mains		function ok
On battery	power down	No function
	"wake up"	Function ok



Modular Junction Box - MJB5 Plus AOC



The modular junction box MJB5 Plus is designed for use together with OpenBus™ control boxes.

The MJB5 Plus makes it possible to connect multiple hand controls and attendant controls. It can even be used for charging or to connect the Under Bed Light and 3rd party products.

MJB5 Plus version 509

The AOC is an Analogue to OpenBus™ Converter. It is the perfect match for especially medical applications where the customer needs to add own products or 3rd party controls in an OpenBus system, e.g. multi-purpose foot switches.

The MJB5 AOC is available with or without power request.

Usage

Compatibility:	Alle OpenBus products except CB20
Operation temperature:	+5 °C to +40 °C
Storage temperature:	-10 °C to +50 °C
Relative humidity:	20% to 80% – non-condensing
Atmospheric pressure:	700 to 1060 hPa
Meters above sea level:	Max. 3000 meters
Latex free:	Yes
Approvals:	IEC60601-1 ANSI/AAMI ES60601-1 CAN/CSA-22.2 No 60601-1

Port 3 is not available

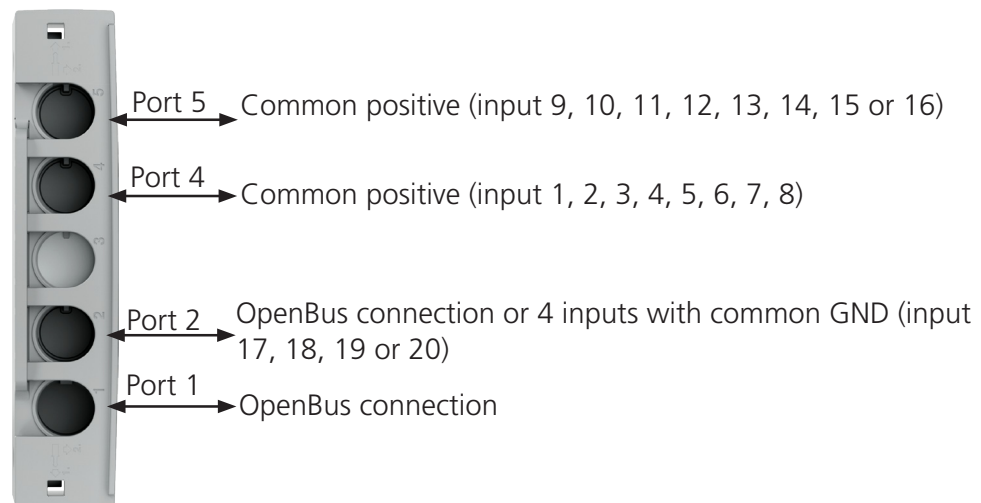

The product label is added for correct connection to the ports



The MJB5 AOC has 4 ports.

Port 1 is for OpenBus connection.

Port 2 has 4 common ground switch inputs or an OpenBus hand control.

Port 4 has 8 common positive switch inputs or an analogue hand control.

Port 5 has 8 common positive switch inputs or an analogue hand control.

Port 1 for connection to the control box and port 2 can be used for an OpenBus control. The standard inputs are made so that a system containing an analogue hand control can be used for an OpenBus control box in port 4 or port 5.

AOC pin connections

Please be aware of the cable and pin orientation.

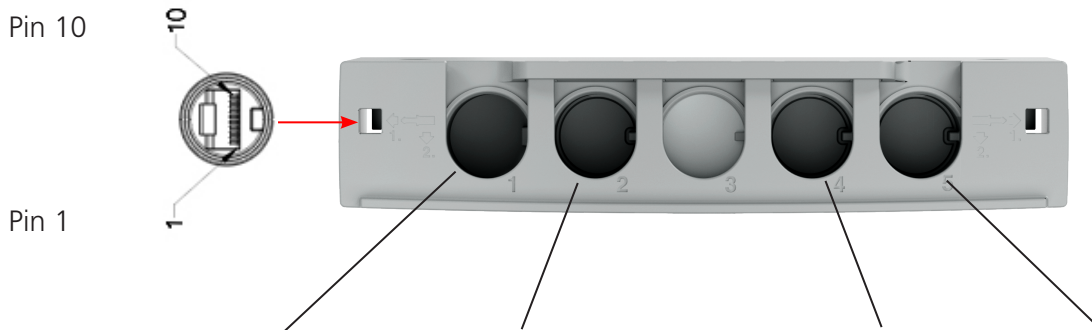

Port/pins	Port 1	Port 2	Port 3	Port 4	Port 5
		Common ground		Common positive	Common positive
Port used for	OpenBus connection	OpenBus™ connection OR extra 3rd party connection		3rd party connections	3rd party connections
Pin1				GND	GND
Pin2		GND		Vperm*	Vperm*
Pin3				Input 1	Input 9
Pin4				Input 2	Input 10
Pin5				Input 3	Input 11
Pin6				Input 4	Input 12
Pin7		Input 17		Input 5	Input 13
Pin8		Input 18		Input 6	Input 14
Pin9		Input 19		Input 7	Input 15
Pin10		Input 20		Input 8	Input 16

*: The voltage can vary from 18 V on battery and up to 50 V on mains with CO control boxes.

	PORT 1	PORT 2	PORT 3	PORT4	PORT 5
Hardware version 0	OpenBus	NO PWR*		NO PWR	NO PWR
Hardware version 1	OpenBus	PWR		PWR	PWR
Hardware version 2	OpenBus	PWR		NO PWR	NO PWR
Hardware version 3	OpenBus	NO PWR		PWR	PWR

*PWR = Power Request

Note - To be able to activate an actuator, it is necessary to use a signal with Power Request.

Requirements for 3rd party products

When the connection is activated the resistance value must be $<100 \Omega$. When there is no activation the resistance value must be $>1 \text{ M} \Omega$. As the MJB5 AOC is to be used with 3rd party products, it needs to be designed with the following isolation: minimum 1 MOPP (creepage distance/clearance).

E.g. 1 MOPP at 60 VAC or 85 VDC

Creepage distance 2.3 mm

Clearance 1.2 mm

Cable CAB917004 is a modular cable with straight jack plug and 10 open-end wires. It is used between Port 4 and/or Port 5 and 3rd party products.

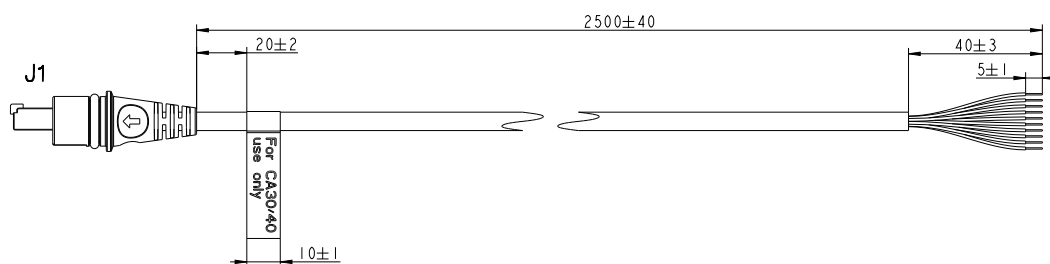

Standard configuration

Table 1: Overview of pin activation and OpenBus codes

When a pin is activated, different OpenBus codes from port 4 and port 5 will be sent.

Table 1 is the standard configuration.

Example: If Pin 3 is activated, it will send OpenBus code H1 from port 4 and H11 from port 5.

Table 1

Pin	Wire colour	Port 1	Port 2	Port 4	Port 5
Pin 1	Black			GND	GND
Pin 2	Red			Vperm*	Vperm*
Pin 3	Orange			H1	H11
Pin 4	Green			H0	H10
Pin 5	White			H3	H13
Pin 6	Blue			H2	H12
Pin 7	Purple			H5	H15
Pin 8	Yellow			H4	H14
Pin 9	Brown			H7	H17
Pin 10	Grey			H6	H16

Table 2

Function CA30/CA40	Function CB6P2	Pin
		Pin 1
		Pin 2
CH1 in	CH1 in	Pin 3
CH1 out	CH1 out	Pin 4
CH3 in	CH2 in	Pin 5
CH3 out	CH2 out	Pin 6
CH2 in	CH3 in	Pin 7
CH2 out	CH3 out	Pin 8
CH4 in	CH4 in	Pin 9
CH4 out	CH4 out	Pin 10

*: The voltage can vary from 18 V on battery and up to 50 V on mains with CO control boxes.

Table 2: Overview of pin activation and channels in systems with an analogue control box. When an analogue hand control is combined with analogue control box and it is connected to the MJB5 AOC, the analogue signals will be converted to OpenBus signals.

Example: If an analogue hand control is connected to CA30/CA40 and CH1 is activated on 'button X', 'button X' is pin 3. If this hand control is connected to the MJB5 AOC, it will give an 'H1' or 'H11' OpenBus code when connected to port 4 or port 5.



MJB5 Plus AOC Special Recommendations

When the MJB5 Plus AOC with or without power request is being used on a system with battery, the functionality will follow the power-down mode of the control box.

If there is no power request on the inputs, it is not possible to wake-up the control box via the MJB5 AOC inputs when the control box is in power down.

Please note that the MJB5 AOC or the OpenBus unit will be damaged if they use Vpermanent and are attached to port 4 or port 5. An example of an OpenBus unit using Vpermanent could be the scale solution including QLCI2.

MJB5 Plus mounting without bracket

MJB5 Plus can be mounted directly on the application from the MJB5 Plus side or via the top.

It is recommended to use screw type DIN912 M4 for mounting without the bracket.

When mounting, ensure that a screw torque limit of 1.0 Nm is not exceeded.

Mounting from the MJB5 Plus side



Mounting from the MJB5 Plus top



Unlocking of cable locking mechanism

If a cable needs to be replaced or added, we recommend to open the cable locking mechanism as described below and demonstrated in our video on LINAK.com - MJB5 Plus section brochures and manuals.

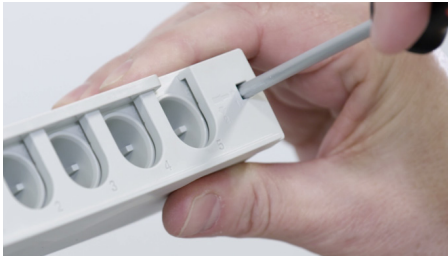

Video guide available on www.linak.com



1. Insert a pin or screwdriver with a diameter of 3.5 to 4 mm.



2. Pull downwards until a click sound is heard. Repeat this for the other locking hole.



3. The cable mechanism is now unlocked.

Locking of cable locking mechanism



Video guide available on www.linak.com



1. Align the locking mechanism with the MJB5 Plus.



2. Press the cable locking mechanism down until you hear a click sound.



3. Slide the mechanism forward until you hear another click sound.



4. MJB5 Plus with a locked cable mechanism.

Modular plug with wide alignment groove

To be used with LINAK products.

Can be connected to all ports in the MJB5 Plus, both ports with narrow and wide alignment grooves.

with narrow and wide alignment grooves.

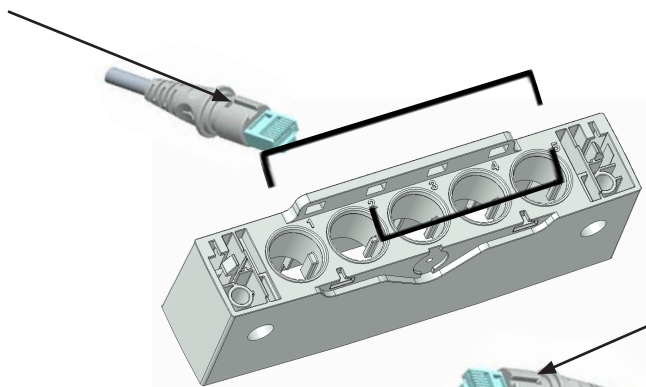

Modular plug with narrow alignment groove.

To be used with 3rd party products.

Can only be connected to ports in the MJB5 Plus with narrow slit. This is to prevent 3rd party products to interfere with the OpenBus™ connections.



Open-end cable:

0964399: Open end cable for Under Bed Light internal and external and switch input. Length 1500 mm.

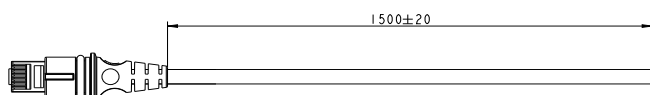

Multi-flexible mounting bracket for MJB5 Plus - article no. 1015W1010-A

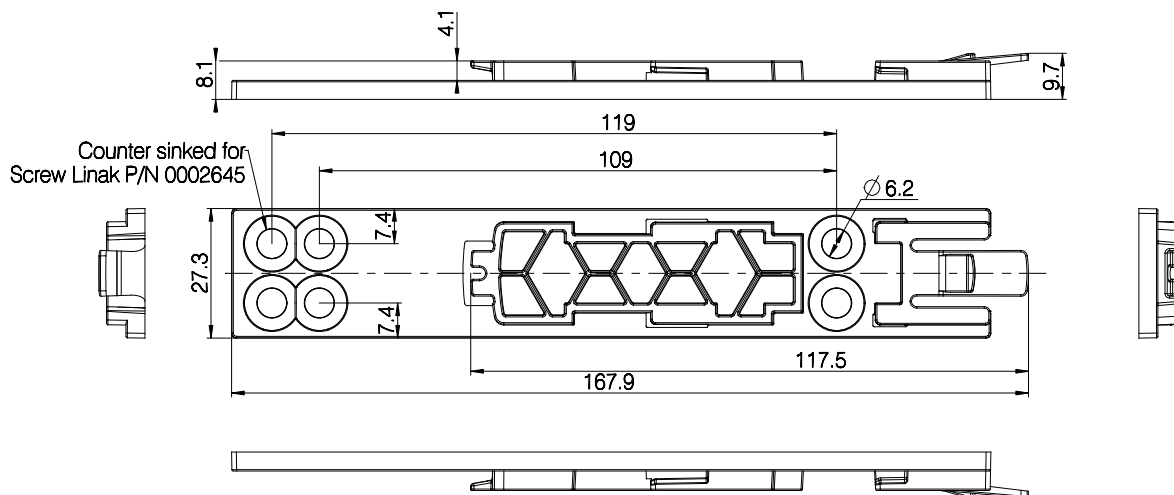

Drawing no.: 0835012

Mount the bracket on the side or the back of the MJB5 Plus.

If it is necessary to dismount the MJB5 Plus from the application, we recommend to use the bracket for mounting.

Use special screws type WN1423 K60x16, ordering no. 0002645.

The screws must be mounted with a torque of maximum 1,0 Nm. The screw head will then be flush with the bracket.

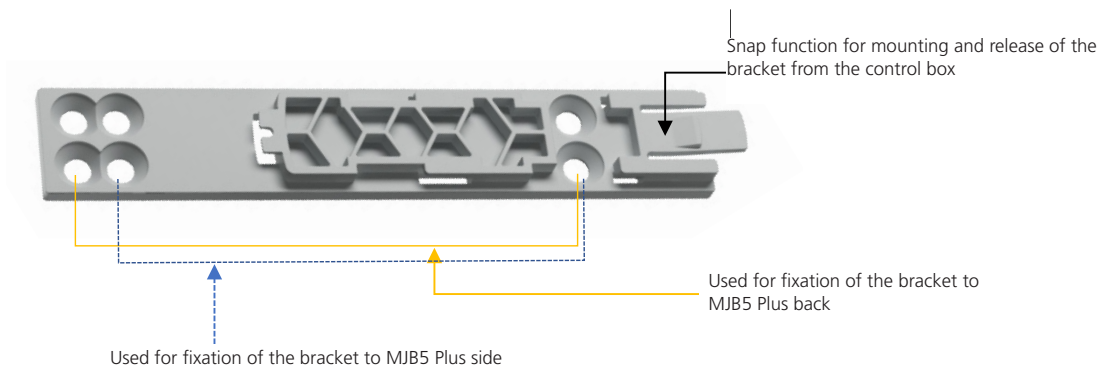

The bracket is very flexible for mounting but we recommend one of the following fixations.

Bracket fixation to the MJB5 Plus back:



Bracket fixation to the MJB5 Plus side:

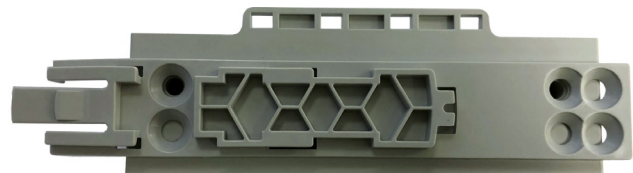

The MJB5 Plus bracket is for mounting on the CO and CB OpenBus control boxes.

Mounting examples

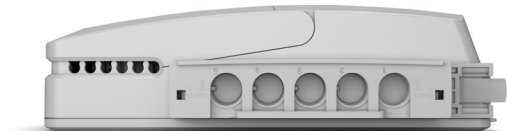
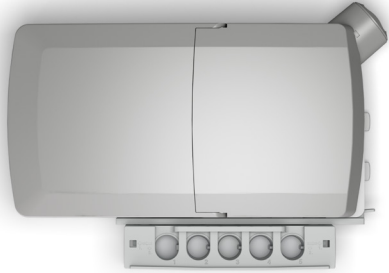
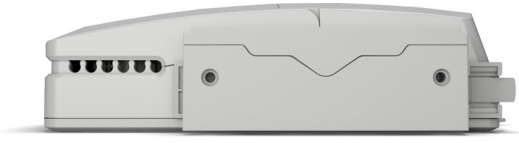

MJB5 Plus with bracket mounted on the back.

MJB5 Plus mounted on the side of the control box.

Power Junction Box - PJB4



The LINAK® Power Junction Box PJB4 branches one PCP port out to 3 ports. The PJB4 can be used with all control boxes equipped with a PCP port.

The PJB4 can connect up to 3 batteries (3 x BA22), for instance in advanced mobile applications that need high battery capacity. It may also be used to connect other PCP devices to the control box system.

Usage

Operation temperature:	+5 °C to +40 °C
Storage temperature:	-10 °C to +50 °C
Compatibility:	Compatible with LINAK Bluetooth Low Energy (BLE) control boxes. Please contact LINAK.
Relative humidity:	20% to 80% – non-condensing
Atmospheric pressure:	700 to 1060 hPa
Meters above sea level:	Max. 3000 meters
Approvals:	IEC60601-1 ANSI/AAMI ES60601-1 CAN/CSA-22.2 No 60601-1



Mounting bracket (frame flat)

Article No. 1015W1001

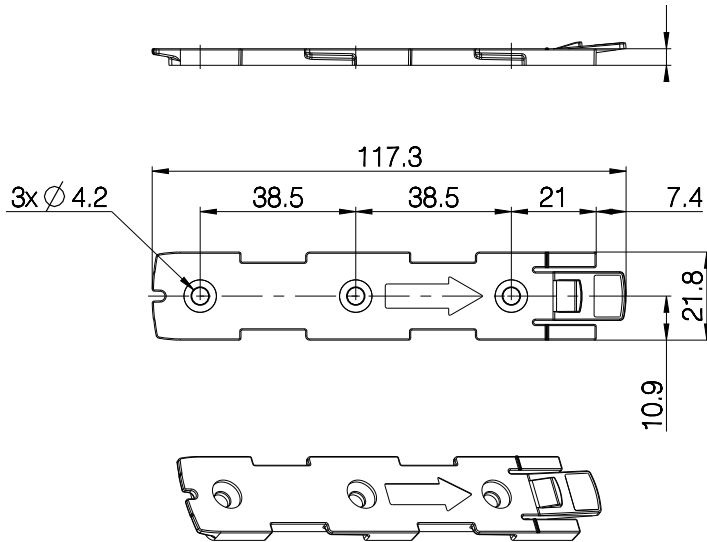

Drawing No.: 1015W4001

Mounting bracket (frame flat) w/M4 nuts

Article No. 1015W9009

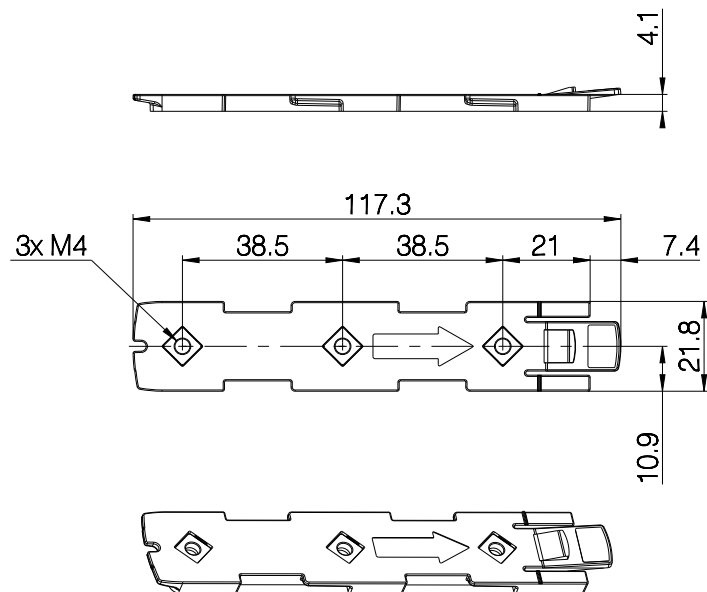

Drawing No.: 1015W4009

It is recommended to mount the PJB4 in a position that allows water to escape.

Recommended torque: 0.6Nm +/-0.1

The bracket can be mounted to the bed frame or any other application by following one of these procedures:

- M5 machine screw with flat washer to be fixed through bracket with nut on the rear side
- Self-tapping screw to be placed through bracket and onto the frame

Mounted on frame

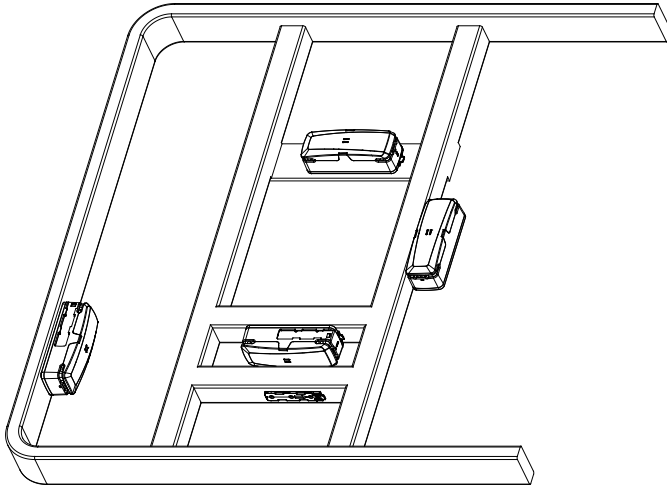

Drawing No.: 1038W4003



Cables

PJB4 has a uniquely designed cable lid. The lid also works as an integrated cable lock when closed.

1. Mount cable plugs in the control box
2. Close lid until lock snaps into place (see arrows)

To allow free access to the cables, the lid has to be removed. It is possible to remove the lid by means of a screwdriver or similar, lifting the lid in each side and pulling it away from the housing.



Recommendations

- Never use more than 3 cables in the path where high currents are drawn
- Always use matching cable plug of the respective product
- Push plugs fully into correct sockets and make sure that the plugs are completely inserted
- Fix the lid and close it until locked in place



Recommendations

- If the system is overloaded and the fuse inside PJB4 blows, the system cannot be operated. LINAK recommends to use quick release actuators or actuators with manual lowering in the application. These will allow functions to be lowered manually in case of a PJB4 malfunction due to misuse/abuse.
- If the application has other basic safeties than “no unintended movement”, it must be considered in the risk analysis for the end application. LINAK disclaims any liability.



Warnings

- Always check correct assembly after mounting and service to ensure that the cable lock is fixed.
- Always use approved chemicals for the housing as the plastic may deteriorate due to certain chemicals. As a result, water may accumulate/gather in the housing.
- To avoid cable interruption, electrical failure or system disturbance, make a proper cable installation and inspect regularly for wear and damage. Defective parts must be replaced.



QLCI2



The Quad Load Cell Interface 2 (QLCI2) for the hospital and care segment is a scale system accessory with weighing capabilities and Out of Bed functionality.

The housing makes the QLCI2 easy to mount by unique slide-on brackets and has an IPX6 Washable DURA™ ingress protection.

The QLCI2 supports the LINAK® OpenBus™ system, offering a high level of customisation.

LINAK A/S delivers the OpenBus system only and is not responsible for any products (i.e. products from 3rd party suppliers) other than LINAK products or the compatibility of such products with the LINAK OpenBus system.

Usage

Operation temperature:	+5 °C to +40 °C
Storage temperature:	-10 °C to +50 °C
Relative humidity:	20% to 80% - non-condensing
Atmospheric pressure:	800 to 1060 hPa
Meters above sea level:	Max. 3000 meters
Approvals:	IEC60601-1 ANSI/AAMI ES60601-1 CAN/CSA-22.2 No 60601-1 EN 45501/OIML R76 EU type examination according to 2014/31/U
Compatibility:	All OpenBus control boxes
Flammability rating:	UL V0
Latex free:	Yes

Mounting

Mounted on frame

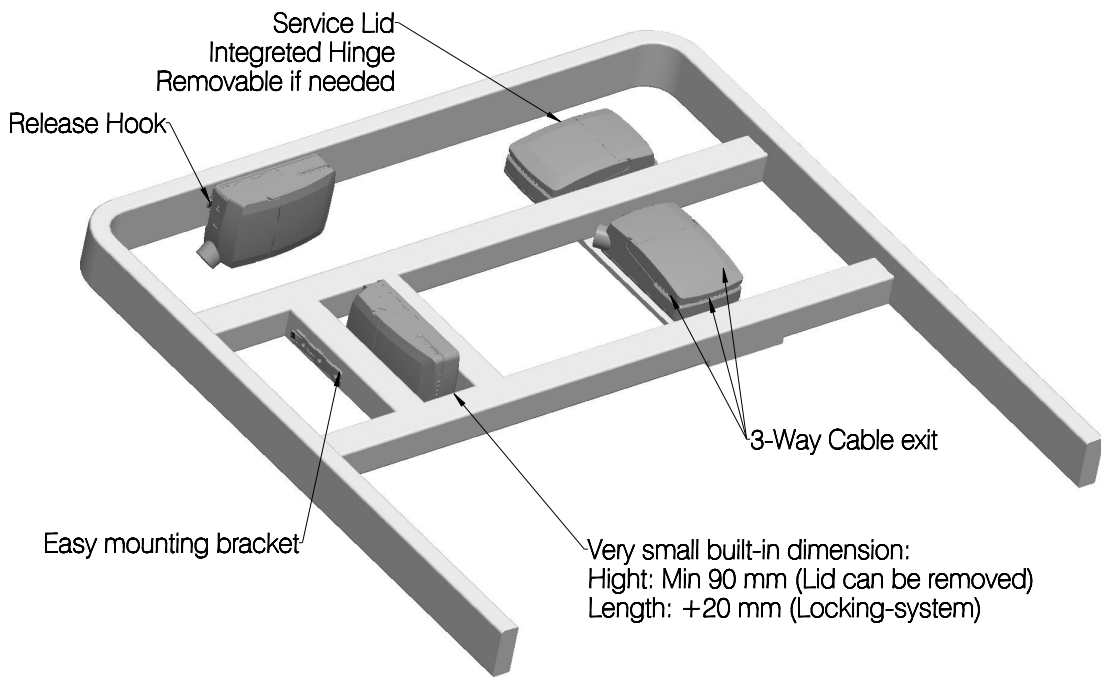

Drawing No: 1013W4008

Mounting bracket (frame flat)

Article No. 1015W1001

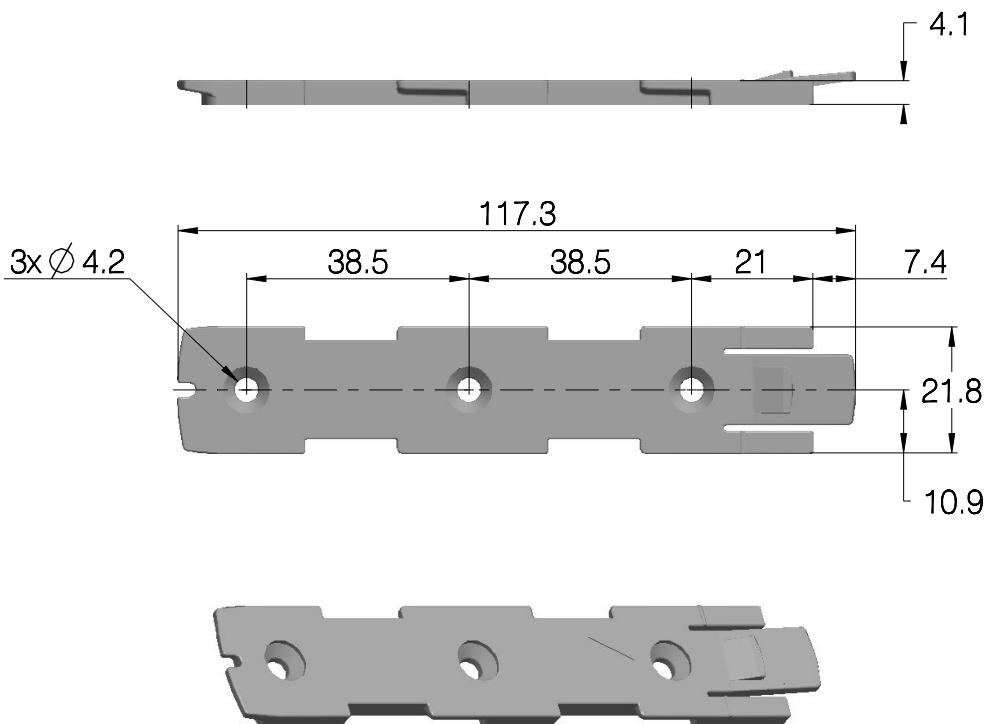

Drawing No.: 1015W4001



Mounting bracket (frame flat) w/M4 nuts

Article No. 1015W1009

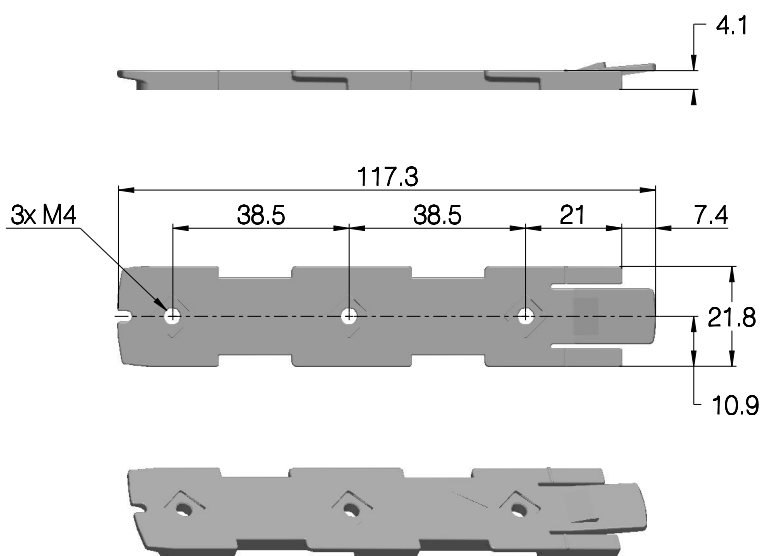

Drawing No.: 1015W4009

It is recommended to mount the QLCI2 in a position that allows water to escape.

Recommended torque: 0.6Nm +/-0.1

The bracket can be mounted to the bed frame or any other application by means of one of the following mounting procedures:

- 1) M6 nut to be placed in bracket and fixed with M6 bolt from the rear side.
- 2) M5 machine screw with flat washer to be fixed through bracket with nut on the rear side.
- 3) Self-tapping screw to be placed through bracket and onto the frame.

The load cells should be mounted in the bottom frame to avoid that adjustment of the top frame affects the measurements.

The load cells must be mounted so that the only force applied is the gravitational force of the load to be measured.

Mounting of cables and cable lock

The QLCI2 have a uniquely designed cable lid. The lid also works as an integrated cable lock when closed.

1. Mount load cell cable plugs in QLCI2
2. Calibrate the system
3. Mount blind plug in calibration port
4. Close lid until lock snaps into place
5. Place calibration void label - only one is needed

To allow free access to the cables, the lid has a rest position when completely opened. It is possible to remove the lid by lifting it a few degrees and pull it away from the housing under tight mounting conditions.

1 Mount load cell cables



2 Calibrate the system

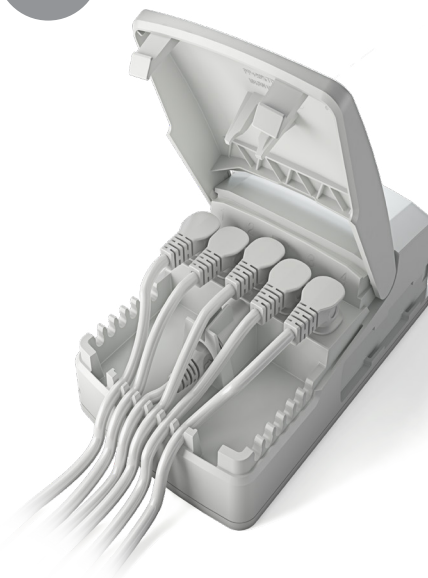

3 Mount blind plug



4 Close lid until it snaps

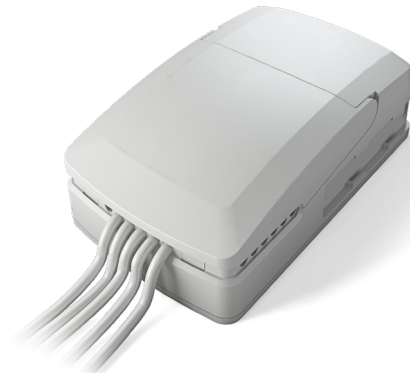

5

Place void label

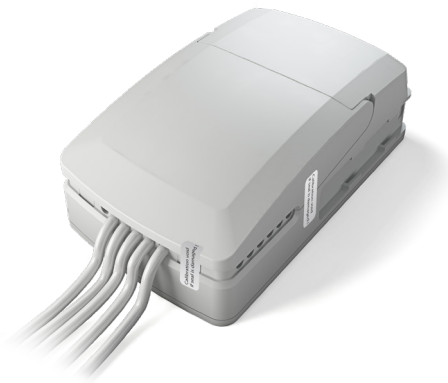

Only 1 label is required. The label can be placed anywhere along the opening of the lid on the QLC12 box.

Calibration

There are different ways of calibration:

1. Calibration via calibration cable and calibration software
2. Calibration via scale hand control (e.g. HB100)
3. Calibration via console program

Calibration via calibration cable and calibration software

In this way of calibration, a computer with the calibration software installed is needed. In addition to that, a special calibration cable is needed to connect the computer to the QLCI2.

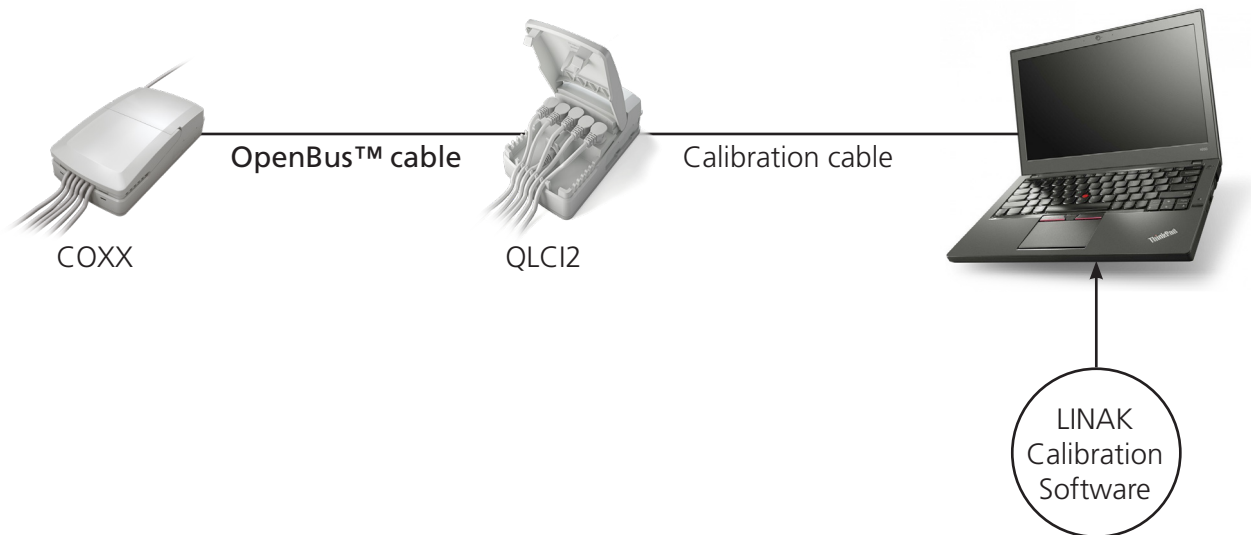

Calibration tool software

The calibration software is used to intuitively calibrate the QLCI2. The user is guided through the calibration in detailed steps and gets clear feedback when completing parts of the calibration.

The LINAK Calibration Software can be found under Support tools on LINTRA.

A detailed walk-through of the calibration process can be found in the calibration guide (File → Help)

The screenshot shows the 'Input values' dialog box in the LINAK Calibration Software. It has tabs for 'Calibration', 'Gravity', 'Loadcell', and 'Report'. The 'Calibration' tab is active, showing two options: '1-Point calibration' (selected) and '4-Point calibration'. Below these are input fields for various parameters:

Parameter	Value	Unit	Value	Unit
Maximum weight	500	kg	1102	lb
Minimum weight	0	kg	0	lb
Weight intervals (e)	0.5	kg	1.1	lb
Detailed weight	0.1	kg	0.2	lb
Maximum Tara	50	kg	110.2	lb
Include pounds	<input checked="" type="checkbox"/>			
In-system calibration permission	Full calibration			
Pin code	Fixed PIN 0001			
NO. of calibration weights	1			
Calibration weight load	10000 g			

At the bottom of the dialog is a 'Save & Close' button.

Input values

Calibration Gravity Loadcell Report

1-Point calibration 4-Point calibration

Only the center needs to be calibrated All four corners of the bed needs to be calibrated

Maximum weight 500 kg 1102 lb

Minimum weight 0 kg 0 lb

Weight intervals (e) 0.5 kg 1.1 lb

Detailed weight 0.1 kg 0.2 lb

Maximum Tara 50 kg 110.2 lb

Include pounds

In-system calibration permission Full calibration

Pin code Fixed PIN 0001

NO. of calibration weights 1

Calibration weight load 10000 g

Save & Close

When using the calibration software for the first time, the "input values" menu pops up automatically. Several settings must be filled in to be able to calibrate the QLCI2.

Calibration tab

1-point calibration	4-point calibration
Only the centre of the bed needs to be calibrated.	Each corner needs to be calibrated.
Weight precision can not be guaranteed. Weight distribution on the bed will have an impact.	The calibrated weight will be most accurate.

Input values

Calibration Gravity Loadcell Report

Local G 9.82 m/s²

Destination G 9.81 m/s²

+

Save & Close

- Marking plate settings
The data input of this section will determine the marking plate. If pound is deselected, it will not show up as an option on the display unit.

- Calibration weights
Select number of weights and each calibration weight load.

Gravity tab

- Local gravity: The gravity in m/s² at the place where the calibration is performed.
- Destination gravity: The gravity in m/s² of the destination. This can be entered on-site and does not need to be known when calibrating.

Input values

Calibration Gravity Loadcell Report

Calibration report path Browse

C:\LINAK\QLCI2\Reports

Report image path Browse

Save & Close

Report tab

After calibration, a report will be saved on the PC. The default path is "C:\LINAK\QLCI2\Reports", but can be changed.



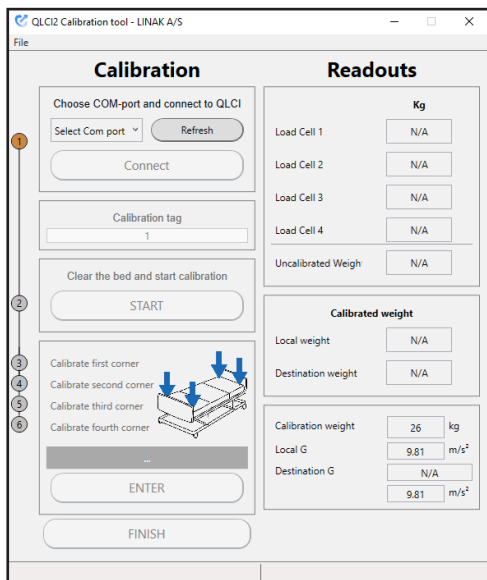

Starting a calibration

When the correct COM-port is selected, the QLCI2 can be connected.

After successful connection, the calibration tag can be changed and readout data will be shown. The "Start" button will also be enabled.

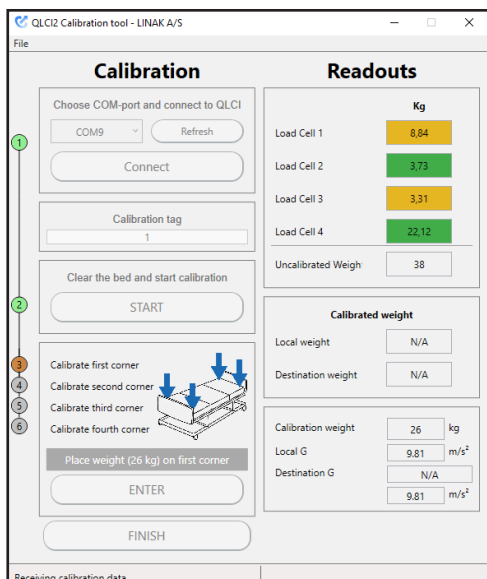

Calibrating the bed

Depending on the calibration method (1-point or 4-point), there will be one or four major steps when calibrating the bed. The load cell readout will turn yellow to indicate an unstable load. When the readout turns green, the "Enter" button will be enabled and the first calibration step is complete.

Finishing

When the calibration is finished, a log will be saved on the PC and the data will be sent to the QLCI2.

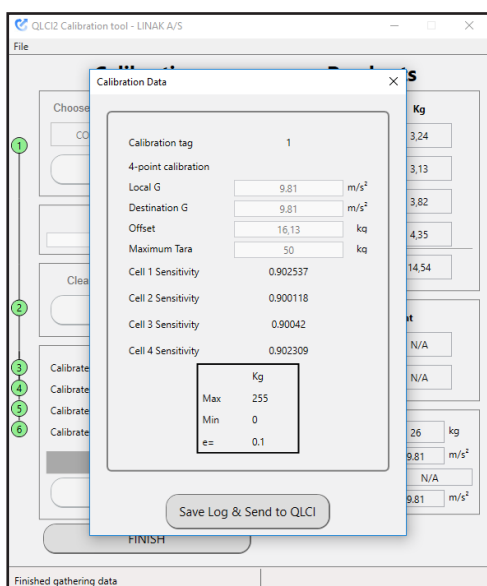

Calibration via scale display unit

To calibrate the QLCI2 via a scale display unit, there is no need for an additional calibration SW or a calibration cable. The calibration is performed via the 'Scale calibration' function, which is placed under Settings - Advanced. (This feature can be disabled via calibration tool)

Press OK button to get into the 'Scale settings' feature. Please note that the calibration function is password-protected and the default password is '0001'. Use the up and down arrow keys to change each digit and use left and right arrow to move between digits. Press 'OK' button to enter the password.

If calibration on scale display unit is required, be aware that system calibration is enabled by default.

List menu inside 'Scale calibration':

Gravity D, m/s ² :	The gravity of the destination in m/s ² . In order to type the new value and navigate between the digits, simply use the arrow keys. Press OK button, when the new value is typed.
Pounds supported:	If selected, the marking plate in the display will also include the equivalent settings and the user can select between pounds and kg.
Set new code:	To change the default code to enter the calibration menu. In order to type the new code and navigate between the digits, simply use the arrow keys. Press OK button, when the new code has been typed.
Scale calibration:	<p>Opens the calibration menu (1-point calibration), including two list items together with the marking plate view:</p> <p>Calibr. weight: Weight of the calibration load in kilograms. In order to type the new weight and navigate between the digits, simply use the arrow keys. Press OK button, when the new weight has been typed.</p> <p>Start calibration: When all the settings are done, press the OK button, when start calibration item is selected.</p>

Steps in 'Start calibration' mode:

Establish no load:	<p>Remove any weight on the application that is not intended to be a weight of the application and press OK to proceed.</p> <p>It is recommended to make calibration without for instance the mattress and other things that the end users can change themselves.</p>
Establish calibration load:	Place your calibration weight centrally on the application and press OK to proceed.
Calibration complete:	Calibration is successfully completed. Press OK to save the calibration data.





Warnings

- In general the load cells are not living up to 2 MOPP, which is okay as long as all other parts comply with 2 MOPP and the load cells are electrically connected to the bed frame. This is to make the bed one electrical unit.



Recommendations

Installation

- It is recommended to mount the load cells on the bottom frame to ensure a stable system.
- Do not mount wheels directly into the load cell.
- Shielded load cell cables will be damaged if exposed to sharp bends. Therefore, if bended, cables should have a minimum bending radius of 60 mm.
- It is not allowed to bend load cell cables repeatedly, so mount cables on non-moving parts, like the bed frame.
- Load cell cables should not exceed a length of 2700 mm.
- In Europe weight systems are subject to important legal restrictions. The LINAK Weighing System is approved in accordance with EN45501. The used load cells must be OIML approved as well (this is not included in the LINAK approval).
- Do not mount the QLCI2 directly on actuators.
- Load cell cables are not to be mated more than 40 times.

Calibration and use

- Before calibrating, the application and components should be allowed to acclimate to ensure that they have the same temperature as the surrounding environment.
- For optimal performance, the QLCI2 should be calibrated with a load similar to the in-use weight. For instance an application for lighter loads would benefit from having the bed calibrated with a lighter calibration load than an application for heavy use.
- The application will be most precise when calibrated with a load slightly above the in-use weight.
- Calibrate the application on a stable base.
- Make sure that no components or cables touch the floor, as it may lead to incorrect measurement.
- While performing a zero or auto-compensation and the handheld control is not placed on the application, the weight of the attendant control is not a part of the total weight. It leads to an incorrect measurement on the scale display, when the handheld control is placed on the application.
- When using auto-compensation or zeroing, do not touch the application or exert other external impacts on the application as this can result in incorrect measurements.
- Be aware that while the handheld control is not placed on the application and if its cable is pulled, it can lead to incorrect measurement on the scale display.
- When using the scale system, it is recommended to also have the bed in horizontal position.



Simulator Tool



The Simulator Tool is a software that can be used to simulate hand control functions on OpenBus™ and analogue actuator systems. With the Simulator Tool, sequences of actuator movements can be programmed and repeated in order to test actuator systems.

USB to OpenBus gateway

The gateway acts as an interface between the Simulator Tool Software and the OpenBus control box. Together with the Simulator Tool Software, it can be used for test and demo purposes only.

It is not allowed to use the product as a control in any commercial application.

It has a USB B-input connection from the computer/laptop.

As output connection it has an RJ45 jack plug for connection to the control box.

The gateway is powered through the OpenBus connection to the control box.

The housing has 3 LEDs on the front.



OpenBus: This LED indicator shows if connected to OpenBus system. (power indicator)



: This LED indicates that USB is connected (Requires power from the OpenBus connection to work).

PRQ: This LED indicates that active power request is active.

Limitations

Note that an OpenBus system that has powered down (8 V missing) cannot be woken up by the USB to Openbus gateway!

Although the USB to Openbus gateway sets a keep power bit, it might be neglected by some control boxes that will power down after a period of time. (Typically 2 minutes)

For cycle testing of such systems (typically battery equipped), that powers down during the cycle, a special control box software that has been stripped for the power down feature is needed.



Warnings

- The LINAK Simulator Tool is to be used as a test tool or demo tool only. It is not allowed to use the software and accessories as a control in any commercial application.
- Potentially dangerous situations resulting from automated movement generated by the Simulator Tool Software must be considered and assessed before starting any action.
- Please note that over time the actual movement of an actuator within a fixed activation time may vary due to changed friction inside the actuator or especially when a battery-driven system loses power. Close inspection and required adjustment is necessary to obtain the wanted movement over time and to avoid potentially dangerous situations.
- The generated test report itself is not a legal proof that a system has physically moved the actuators the number of times stated and cannot be used as such. The time of activation listed in the report generated is not necessarily the same as the time of actuator movement. It just shows how long the function has been activated (equal to the time you have pressed the button on the hand control). The actuator can be in end-of-stroke position or the function can be locked and therefore the actuator itself doesn't move. It is recommended to use a physical counter or similar to verify the actual actuator movement.



Recommendations

- See to it that sufficient pauses are kept between activations, so that the duty cycle of each actuator type is respected.



Safety/Signal Limit Switch (SLS)



There are 2 types of SLS switches, an analogue and an OpenBus™ type.

The analogue SLS can be used as safety feature to cut off the current to the actuator. The SLS is available with 1 or 2 switches (activated by the same button). It can be placed to prevent an unintentional positioning of the various frame segments in relation to each other or simply as an external limit switch to protect the frame against the full thrust of the actuator in end position. The actuator stops immediately when the button is pressed.

The OpenBus SLS is to be used together with the OpenBus control boxes.

It is available both as a passive and as an active type. It comes with 1 switch, Normally Open (NO). The standard OpenBus SLS is not to be used for safety (Signal Limit Switch).

Both types can be used as an external signal unit that gives a signal to the control box. This signal can limit or interrupt the functions on for instance a bed or can be used to start an OpenBus function.

Usage

Operation temperature:	+5 °C to +40 °C
Storage temperature:	-10 °C to +50 °C
Relative humidity:	20% to 80% – non-condensing
Atmospheric pressure:	800 to 1060 hPa
Meters above sea level:	Max. 3000 meters
Approvals:	IEC60601-1 ANSI/AAMI ES60601 CSA CAN/CSA-C22.2 NO. 60601

OpenBus SLS functionality

The OpenBus SLS is normally an open switch. When the switch is activated, ID1/Hxx is set on the OpenBus. The OpenBus SLS can be ordered as an active or passive type.

The active type has power request when the switch is activated and can be used for activating a function (actuator movement).

The passive type does not have power request when the switch is activated.

The passive SLS can be used as a brake buzzer switch or as part of an activation, for instance in combination with a hand control, for example HB80.



Recommendations

- It is not recommended to use the standard OpenBus SLS as a safety switch. The control box is not able to detect if the SLS has been disconnected. This requires a special SW for both control box and SLS.
- There can be a risk of conflict with other OpenBus accessories, like HB, when using the OpenBus SLS, it is therefore recommended to make a system/bit overview.



Cable length - Safety Limit Switch

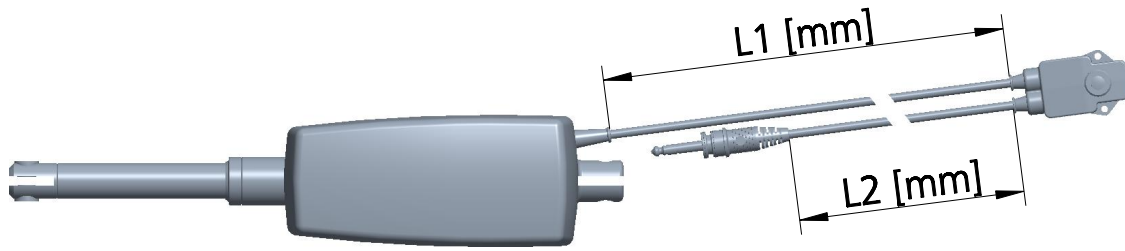

Cable length - Signal Limit Switch

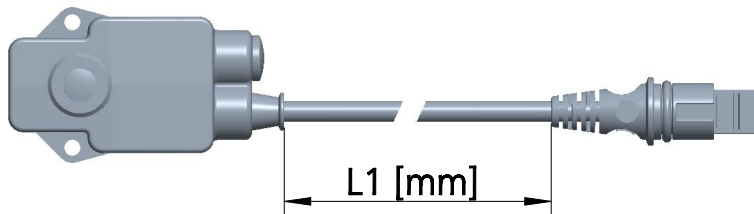

Switch Mode Power Supply - SMPS10



The SMPS10 is a wall-mounted Switch Mode Power Supply typically used for healthcare applications. Having an external power supply means that the application becomes a low voltage unit.

Usage

Compatibility:	LINAK CO/CA solutions that are powered via an external SMPS
Operation temperature:	+5 °C to +40 °C
Storage temperature:	-10 °C to +50 °C
Relative humidity:	20% to 80% – non-condensing
Duty cycle*:	10%, 2 minutes continuous use followed by 18 minutes not in use
Atmospheric pressure:	800 to 1060 hPa
Meters above sea level:	Max. 3000 meters
Approvals:	IEC60601-1

* 10% duty cycle, max. output power is possible at an ambient temperature of 25 °C.

Switch Mode Power Supply - SMPS10 Floor



The SMPS10 Floor model is a universal Switch Mode Power Supply typically used for health care applications. With 100-240 voltage input and a C8 inlet, it can be used globally with any C7 shaver cable. Having an external power supply means that the application becomes a low voltage unit.

Usage

Compatibility:	LINAK CO/CA solutions that are powered via an external SMPS
Operation temperature:	+5 °C to +40 °C
Storage temperature:	-10 °C to +50 °C
Relative humidity:	20% to 80% – non-condensing
Duty cycle*:	10%, 2 minutes continuous use followed by 18 minutes not in use
Atmospheric pressure:	800 to 1060 hPa
Meters above sea level:	Max. 3000 meters
Approvals:	IEC60601-1

* 10% duty cycle, max. output power is possible at an ambient temperature of 25 °C.



Recommendations

- When cleaning the application, make sure that the C8 inlet is completely dry before connecting to mains.
- The SMPS10 must be cleaned at regular intervals to remove dust and dirt and it must be inspected for mechanical damage, wear and breaks.

Under Bed Light (UBL)



The Under Bed Light (UBL) can be mounted under the bed to provide a discrete guiding light when the patient leaves the bed during night. With an Under Bed Light it is easy to switch the light on and off by means of a handset or controlling it automatically with the Out of Bed functionality of the MJB5 Plus with Under Bed Light (Ext.).

Usage

Operation temperature:	+5 °C to +40 °C
Storage temperature:	-10 °C to +50 °C
Atmospheric pressure:	800 to 1060 hPa
Meters above sea level:	Max. 3000 meters
Connectivity:	To be connected to MJB506



Recommendations

- The Under Bed Light (Item P/N.: 0964135) must be mounted on the bed with metal screws in order to maintain ESD protection.



Under Bed Light (UBL) 2



The Under Bed Light (UBL2) provides a powerful light with a good distribution. The UBL2 is to be used for beds within hospitals, nursing homes and in homecare.

The Under Bed Light makes it easier for patients and other people in need of care to find their way at night in the dark to prevent falling accidents and to make them feel safe.

Usage

Operation temperature:	+5 °C to +40 °C
Storage temperature:	-10 °C to +50 °C
Relative humidity:	20% to 80% - non-condensing
Atmospheric pressure:	800 to 1060 hPa
Meters above sea level:	Max. 3000 meters
Approvals:	EN62471 IEC60601-1



Recommendations

- If 2 or more UBL2 products with dimming function are connected to the same application, it is recommended to have a factory reset key to be able to synchronize the dimming direction and light intensity if one of the UBL2s is replaced.
- Screw holes in application are needed for mounting. Inform the customer to use M4 Ø12 screws with Ø12 washer, when mounting the UBL2. Max. torque 2.5 Nm.
- Hot-plugging:
Removing or adding any OpenBus™ cables is not allowed when the CB is powered by mains supply!
If needed anyway, follow the below procedure:
 1. Remove mains and wait 5 sec.
 2. Mount or dismount the required cables

If this procedure is NOT followed, it may result in a damaged OpenBus driver circuit. The risk of a damaged circuit increases if the accessory has a high start current (in rush current).
- There can be a risk of conflict with other OpenBus accessories, like HB, ACP, etc. when using the OpenBus UBL2, it is therefore recommended to make a system/bit overview.
- Always use locking mechanism and O-ring
- Sockets not used must be fitted with blind plugs to ensure IP degree
- The UBL2 must be mounted on a plane surface and casing must not be subject to impact or any kind of stress.



Under Bed Light (UBL) 4 Motion



The Under Bed Light, UBL4 Motion, consists of a bed light with a sensor that activates when motion is detected. It is intended for use within primarily nursing homes and homecare and works with LINAK® OpenBus™ systems.

Usage

Operation temperature:	+5 °C to +40 °C
Storage temperature:	-10 °C to +50 °C
Relative humidity:	20% to 80% – non-condensing
Atmospheric pressure:	700 to 1060 hPa
Meters above sea level:	Max. 3000 meters
Compatibility:	LINAK analogue and OpenBus™ control boxes
Approvals:	IEC60601-1 ANSI/AAMI ES60601-1 CAN/CSA-22.2 No 60601-1



Information

- UBL4 Motion will be ready for use after 2 seconds when connected to mains power
- The PIR sensor sensitivity is indicative and can vary
- The PIR sensor angle and PIR sensor detection range are indicative and can vary
- Daylight sensitivity detector values are indicative and can vary
- UBL4 Motion on battery will follow the power-down mode of the control box, see tables

OpenBus™ control box power mode		UBL4 Motion
On mains		Function OK
On battery	Power down	No function
	Wake up	Function OK

Analogue control box power mode		UBL4 Motion
On mains		Function OK
On battery*		Function OK

* We do not recommend using UBL4 Motion on analogue systems that have a non-protected battery, such as BA16, BA18 and BA19.





Recommendations

- Make sure that the UBL4 Motion detecting lens (PIR sensor) is placed without any obstructions to its field of view to work properly.
- Make sure that the UBL4 Motion detecting lens (PIR sensor) is not subject to impact or any kind of stress.
- The UBL4 Motion must be mounted on a plain surface and the housing must not be subject to impact or any kind of stress.
- Screw holes in application are needed for mounting. Inform the customer to use M4 Ø8 screws with a minimum length of 22 mm. Recommended torque is 1.0 +10% Nm.



Warnings

- **Hot-plugging:**
Removing or adding any OpenBus™ cables is not allowed when the control box is powered by mains.
- If needed anyway, follow the below procedure:
 1. Remove mains and wait 5 sec.
 2. Mount or dismount the required cablesIf this procedure is NOT followed, it may result in a damaged OpenBus driver circuit.
- The risk of a damaged circuit increases if the accessory has a high start current (inrush current).
- Always use locking mechanism and O-ring
- UBL4 Motion is a stand-alone product. If there are two UBL4 Motion lights connected to the system and one of them is activated, only the one that is activated will turn on the light.



USB-A Power Adapter



The USB-A power adapter can be used for charging devices, such as smart phones, tablets and other products which require a USB-A connection. It can deliver up to 7.5 W constant power and is applicable for beds and other healthcare applications within hospitals, nursing homes and homecare.

Usage

Operation temperature:	5 °C to 40 °C
Storage temperature:	-10 °C to +50 °C
Relative humidity:	20% to 80% – non-condensing
Atmospheric pressure:	700 to 1060 hPa
Meters above sea level:	Max. 3000 meters
Latex-free:	Yes
Approvals:	IEC60601-1 UL



Mounting

- It is imperative to mount the female USB-A connector opening facing down to prevent any water ingress (IPX4 requirement)
- Screw holes in application are needed for mounting
- When mounting, a screw torque 0.8-0.9 Nm is recommended.
- For the female USB-A connector, we recommend using pan-head machine screws - alternatively, a cable zip-tie may be used to attach the USB-A connector on a suitable place on the application.

The housing and the female USB-A connector must be mounted on a flat surface, not to be subject to impact or stress. Cables should be attached securely to the application. Cable attachment should not cut or pinch the insulation.

Mounting example

Be aware that in the below example, the female USB-A connector opening is facing downwards to prevent any water ingress (IPX4 requirement).

1. The female USB-A connector is here mounted between the two siderails.
2. The female USB-A connector is here attached with pan-head machine screws. We recommend using pan-head screws to get a bigger surface area between screw and over mold.
3. The female USB-A connector is here attached with a cable zip-tie.

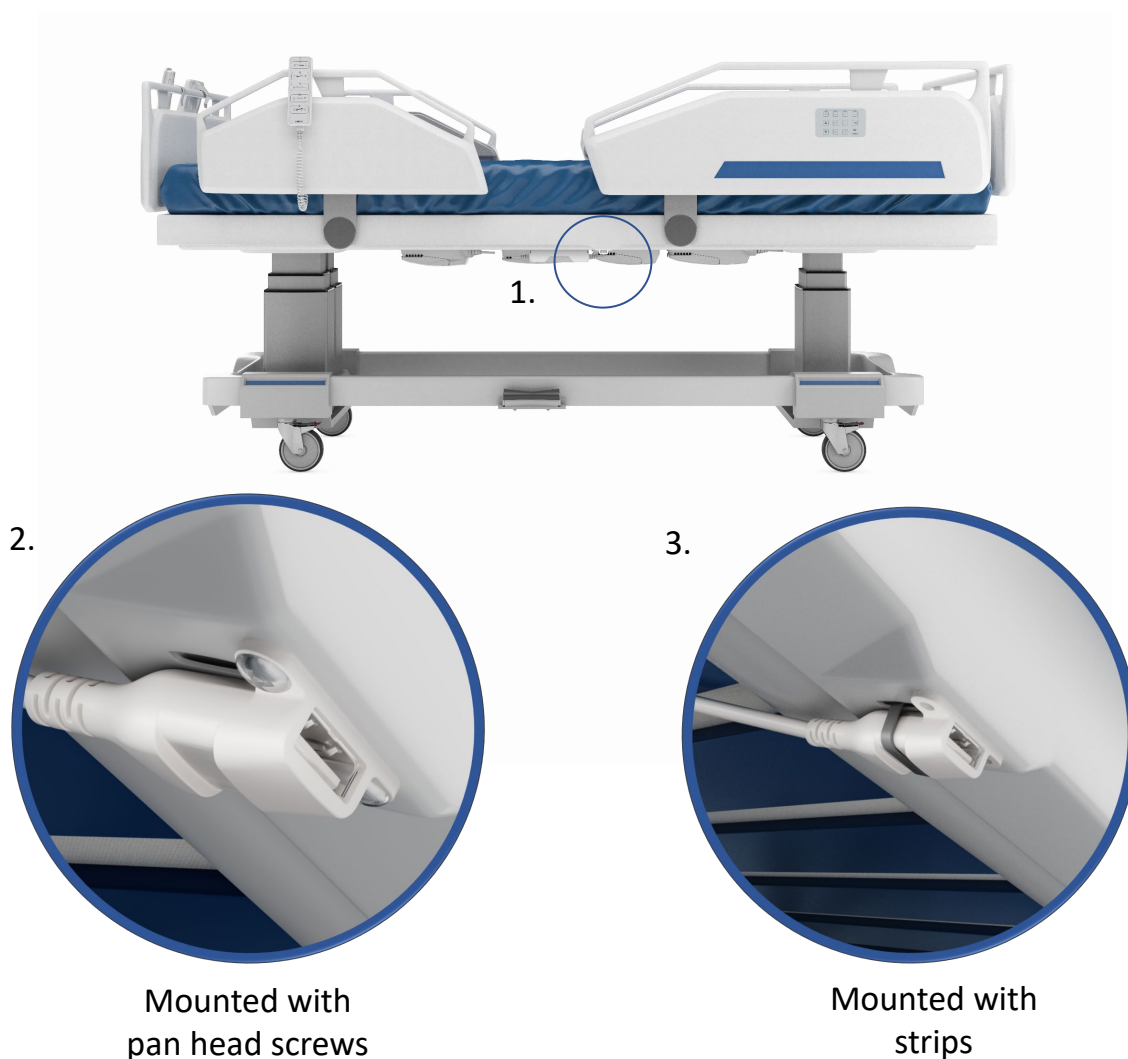



Recommendations

- Always use locking mechanism and O-ring.
- Unused socket(s) must be fitted with blind plug(s) to ensure the IP degree.
- When mounting, a screw torque of 0.8-0.9 Nm is recommended.
- Hot-plugging: removing or adding any cables is not allowed when the control box is powered. If still required, follow this procedure:
 1. Remove power and wait for 5 seconds
 2. Connect or disconnect the required cables

Non-observance of this procedure may lead to damaged product driver circuits in COXX control boxes.

- Clean and wipe with a clean cloth. The cloth may be dampened with an all-purpose cleaner.
- LINAK recommends annual inspection of its products when used in typical medical, hospital, healthcare or assisted living environments.



Warnings

- Using wrong screws or the wrong torque can lead to cracks in the housing.
- The cable is not to be exposed to high pull force or sideways traction.
- Using USB-A Power Adapter with non-compatible control boxes can lead to loss of system performance.
- It is imperative to mount the female USB-A connector opening facing down to prevent any water ingress (IPX4 requirement).



Contacts

FACTORIES

Denmark - Headquarters
LINAK A/S
Phone: +45 73 15 15 15
Fax: +45 74 45 80 48
Fax (Sales): +45 73 15 16 13
Web: www.linak.com

China
LINAK (Shenzhen) Actuator Systems, Ltd.
Phone: +86 755 8610 6656
Phone: +86 755 8610 6990
Web: www.linak.cn

Slovakia
LINAK Slovakia s.r.o.
Phone: +421 51 7563 444
Web: www.linak.sk

Thailand
LINAK APAC Ltd.
Phone: +66 33 265 400
Web: www.linak.com

USA
LINAK U.S. Inc.
Americas Headquarters
Phone: +1 502 253 5595
Fax: +1 502 253 5596
Web: www.linak-us.com
www.linak-latinamerica.com

SUBSIDIARIES

Australia
LINAK Australia Pty. Ltd
Phone: +61 3 8796 9777
Fax: +61 3 8796 9778
E-mail: sales@linak.com.au
Web: www.linak.com.au

Austria
LINAK Zweigniederlassung - Österreich (Wien)
Phone: +43 (1) 890 7446
Fax: +43 (1) 890 744615
E-mail: info@linak.de
Web: www.linak.at - www.linak.hu

Belgium
LINAK Actuator-Systems NV/SA
(Belgium & Luxembourg)
Phone: +32 (0)9 230 01 09
E-mail: beinfo@linak.be
Web: www.linak.be - www.fr.linak.be

Brazil
LINAK Do Brasil Comércio De Atuadores Ltda.
Phone: +55 (11) 2832 7070
Fax: +55 (11) 2832 7060
E-mail: info@linak.com.br
Web: www.linak.com.br

Canada
LINAK Canada Inc.
Phone: +1 502 253 5595
Fax: +1 416 255 7720
E-mail: info@linak.ca
Web: www.linak-us.com

Czech Republic
LINAK C&S s.r.o.
Phone: +42 058 174 1814
Fax: +42 058 170 2452
E-mail: info@linak.cz
Web: www.linak.cz - www.linak.sk

Denmark - International
LINAK International
Phone: +45 73 15 15 15
E-mail: info@linak.com
Web: www.linak.com

Denmark - Sales
LINAK Danmark A/S
Phone: +45 86 80 36 11
Fax: +45 86 82 90 51
E-mail: linak@linak-silkeborg.dk
Web: www.linak.dk

Finland
LINAK OY
Phone: +358 10 841 8700
E-mail: linak@linak.fi
Web: www.linak.fi

France
LINAK France E.U.R.L
Phone: +33 (0) 2 41 36 34 34
Fax: +33 (0) 2 41 36 35 00
E-mail: linak@linak.fr
Web: www.linak.fr

Germany
LINAK GmbH
Phone: +49 6043 9655 0
Fax: +49 6043 9655 60
E-mail: info@linak.de
Web: www.linak.de

India
LINAK A/S India Liaison Office
Phone: +91 120 4531797
Fax: +91 120 4786428
E-mail: info@linak.in
Web: www.linak.in

Ireland
LINAK UK Limited (Ireland)
Phone: +44 (0)121 544 2211
Fax: +44 (0)121 544 2552
+44 (0)796 855 1606 (UK Mobile)
+35 387 634 6554 (Rep.of Ireland Mobile)
E-mail: sales@linak.co.uk
Web: www.linak.co.uk

Italy
LINAK ITALIA S.r.l.
Phone: +39 02 48 46 33 66
Fax: +39 02 48 46 82 52
E-mail: info@linak.it
Web: www.linak.it

Japan
LINAK K.K.
Phone: 81-45-533-0802
Fax: 81-45-533-0803
E-mail: linak@linak.jp
Web: www.linak.jp

Malaysia
LINAK Actuators Sdn. Bhd.
Phone: +60 4 210 6500
Fax: +60 4 226 8901
E-mail: info@linak-asia.com
Web: www.linak.my

Netherlands
LINAK Actuator-Systems B.V.
Phone: +31 76 5 42 44 40 /
+31 76 200 11 10
E-mail: info@linak.nl
Web: www.linak.nl

New Zealand
LINAK New Zealand Ltd
Phone: +64 9580 2071
Fax: +64 9580 2072
E-mail: nzsales@linak.com.au
Web: www.linak.com.au

Norway
LINAK Norge AS
Phone: +47 32 82 90 90
E-mail: info@linak.no
Web: www.linak.no

Poland
LINAK Polska
LINAK Danmark A/S (Spółka Akcyjna)
Phone: +48 22 295 09 70 /
+48 22 295 09 71
E-mail: info@linak.pl
Web: www.linak.pl

Republic of Korea
LINAK Korea Ltd.
Phone: +82 2 6231 1515
Fax: +82 2 6231 1516
E-mail: info@linak.kr
Web: www.linak.kr

Slovakia
LINAK Slovakia S.R.O.
Phone: +421 51 7563 444
Web: www.linak.sk

Spain
LINAK Actuadores, S.L.u
Phone: +34 93 588 27 77
Fax: +34 93 588 27 85
E-mail: esma@linak.es
Web: www.linak.es

Sweden
LINAK Scandinavia AB
Phone: +46 8 732 20 00
Fax: +46 8 732 20 50
E-mail: info@linak.se
Web: www.linak.se

Switzerland
LINAK AG
Phone: +41 43 388 31 88
E-mail: info@linak.ch
Web: www.linak.ch - www.fr.linak.ch
www.it.linak.ch

Taiwan
LINAK (Shenzhen) Actuator systems Ltd.
Taiwan Representative office
Phone: +886 2 272 90068
Fax: +886 2 272 90096
E-mail: sales@linak.com.tw
Web: www.linak.com.tw

Turkey
LINAK İth. İhr. San. ve Tic. A.Ş.
Phone: +90 312 4726338
Fax: +90 312 4726635
E-mail: info@linak.com.tr
Web: www.linak.com.tr

United Kingdom
LINAK UK Limited
Phone: +44 (0)121 544 2211
Fax: +44 (0)121 544 2552
E-mail: sales@linak.co.uk
Web: www.linak.co.uk

DISTRIBUTORS

Argentina
Novotec Argentina SRL
Phone: 011-4303-8989 / 8900
Fax: 011-4032-0184
E-mail: info@novotecargentina.com
Web: www.novotecargentina.com

Colombia
MEM Ltda
Phone: +[57] (1) 334-7666
Fax: +[57] (1) 282-1684
E-mail: servicioalcliente@memltda.com.co
Web: www.mem.net.co

India
Mechatronics Control Equipments India Pvt Ltd
Phone: +91-44-28558484, 85
E-mail: bala@mechatronicscontrol.com
Web: www.mechatronicscontrol.com

Indonesia
PT. Himalaya Everest Jaya
Phone: +6 221 544 8956 /+6 221 544 8965
Fax: +6 221 619 1925
Fax (Sales): +6 221 619 4658
E-mail: hejplastic-div@centrin.net.id
Web: www.hej.co.id

Israel
NetivTech LTD
Phone: +972 55-2266-535
Fax: +972 2-9900-560
E-mail: info@NetivTech.com
Web: www.netivtech.com

Singapore
Servo Dynamics Pte Ltd
Phone: +65 6844 0288
Fax: +65 6844 0070
E-mail: servodynamics@servo.com.sg

South Africa
Industrial Specialised Applications CC
Phone: +27 011 466 0346
E-mail: gartht@isagroup.co.za
Web: www.isaza.co.za

United Arab Emirates
Mechatronics
Phone: +971 4 267 4311
Fax: +971 4 267 4312
E-mail: mechtron@emirates.net.ae

Terms of use

LINAK® takes great care in providing accurate and up-to-date information on its products. However, the user is responsible for determining the suitability of LINAK products for a specific application. Due to continual development, LINAK products are subject to frequent modifications and changes. LINAK reserves the rights to conduct modifications, updates, and changes without any prior notice. For the same reason, LINAK cannot guarantee the correctness and actual status of imprinted information on its products.

LINAK uses its best efforts to fulfil orders. However, for the reasons mentioned above, LINAK cannot guarantee availability of any particular product at any given time. LINAK reserves the right to discontinue the sale of any product displayed on its website or listed in its catalogues or in other written material created and produced by LINAK, LINAK subsidiaries, or LINAK affiliates. All sales are subject to the applicable terms and conditions of sale and delivery available on LINAK websites.

LINAK and the LINAK logotype are registered trademarks of LINAK A/S. All rights reserved.