

# Phased-out products

## **User Manual**

## Contents

<b>Preface</b> .....	<b>5</b>
<b>GENERAL ASSEMBLY INSTRUCTIONS</b> .....	<b>6</b>
<b>DECLARATION OF INCORPORATION OF PARTLY COMPLETED MACHINERY</b> .....	<b>7</b>
<b>Important information</b> .....	<b>8</b>
<b>General warnings</b> .....	<b>9</b>
<b>General recommendations</b> .....	<b>12</b>
<b>General Regulatory Considerations</b> .....	<b>13</b>
<b>General warranty periods</b> .....	<b>13</b>
<b>Electromagnetic Compatibility (EMC)</b> .....	<b>14</b>
EMC Warnings .....	14
EMC responsibilities for LINAK actuator systems .....	15
Electrostatic discharge (ESD) .....	16
RF transmitter/receiver properties.....	17
FCC and IC Statements.....	17
<b>Symbols</b> .....	<b>18</b>
<b>Batteries</b> .....	<b>20</b>
General battery warnings .....	20
Lithium ion batteries .....	21
Lead acid batteries .....	24
<b>System description</b> .....	<b>25</b>
<b>Connecting the system</b> .....	<b>25</b>
<b>General mounting of actuators</b> .....	<b>26</b>
<b>General mounting of control boxes</b> .....	<b>27</b>
<b>General mounting of accessories</b> .....	<b>27</b>
<b>General mounting of controls</b> .....	<b>27</b>
<b>General environmental conditions</b> .....	<b>28</b>
<b>Information on start-up, deinstallation and operation</b> .....	<b>29</b>
Before installation, deinstallation or troubleshooting .....	29
Before start-up .....	29
During operation .....	29
<b>Cleaning</b> .....	<b>30</b>
Cleaning warnings.....	30
IPX6 Washable .....	31
Rinsing aids .....	32
IPX6 Washable DURA™.....	33
Cable wash .....	34

<b>General maintenance</b> .....	<b>35</b>
Maintenance of all LINAK actuators .....	36
Maintenance of all LINAK lifting columns.....	36
Maintenance of all LINAK control boxes.....	36
Maintenance of all LINAK controls .....	36
Maintenance of all LINAK accessories .....	36
<b>Repair and disposal</b> .....	<b>37</b>
<b>Insulation class</b> .....	<b>38</b>
<b>Output ratings</b> .....	<b>38</b>
<b>Troubleshooting</b> .....	<b>39</b>
<b>LA22</b> .....	<b>40</b>
<b>LA32</b> .....	<b>41</b>
<b>LA43</b> .....	<b>43</b>
<b>LA44 IC</b> .....	<b>47</b>
<b>BB3</b> .....	<b>48</b>
<b>BL4</b> .....	<b>49</b>
<b>LC2</b> .....	<b>53</b>
<b>LP2</b> .....	<b>54</b>
<b>LP3</b> .....	<b>55</b>
<b>CA10</b> .....	<b>56</b>
<b>CB6 OBMe</b> .....	<b>59</b>
<b>CB6P2</b> .....	<b>62</b>
<b>CB6S</b> .....	<b>64</b>
<b>CB12</b> .....	<b>66</b>
<b>CB14</b> .....	<b>67</b>
<b>CB16</b> .....	<b>68</b>
<b>CB20</b> .....	<b>71</b>
<b>COBO</b> .....	<b>72</b>
<b>COBO20</b> .....	<b>75</b>
<b>ACM</b> .....	<b>76</b>
<b>ACT</b> .....	<b>77</b>
<b>FS2</b> .....	<b>80</b>
<b>HB20</b> .....	<b>80</b>
<b>HB40</b> .....	<b>81</b>
<b>HB50</b> .....	<b>81</b>
<b>HB60</b> .....	<b>82</b>
<b>HL80</b> .....	<b>82</b>
<b>IRO</b> .....	<b>83</b>

---

<b>BA19</b> .....	<b>84</b>
<b>BA21</b> .....	<b>87</b>
<b>CBJ1</b> .....	<b>93</b>
<b>EBC</b> .....	<b>97</b>
<b>MJB8</b> .....	<b>98</b>
<b>SCALE: QLCI1 and SCO</b> .....	<b>99</b>
<b>SMPS30</b> .....	<b>110</b>
<b>WET Sheet</b> .....	<b>112</b>
<b>Contacts</b> .....	<b>113</b>

## Preface

Dear User,

We are delighted that you have chosen a LINAK® product.

LINAK systems are high-tech products based on many years of experience in the manufacture and development of actuators, lifting columns, desk frames, electric control boxes, controls, batteries, accessories and chargers.

This User Manual does not address the end user. It is intended as a source of information for the equipment or system manufacturer only, and it will tell you how to install, use and maintain your LINAK product/system. The manufacturer of the end product has the responsibility to provide a User Manual where relevant safety information from this manual is passed on to the end user.

We are convinced that your LINAK system will give you many years of problem-free operation.

Before our products leave the factory they undergo full function and quality testing. Should you, nevertheless, experience problems with your product/system, you are always welcome to contact your local supplier.

LINAK subsidiaries and some distributors situated all over the world have authorised service centres, which are always ready to help you.

LINAK provides a warranty on all products (see warranty section).

This warranty, however, is subject to correct use in accordance with the specifications, maintenance being done correctly and any repairs being carried out at a service centre, which is authorised to repair LINAK products.

Changes in installation and use of LINAK systems can affect their operation and durability. The products are only to be opened by authorised personnel.

This User Manual has been written on the basis of the present technical knowledge. LINAK is constantly keeping the information updated and we therefore reserve the right to carry out technical modifications.

The introductory pages of this manual may contain information that is not applicable to the technical product pages and are to be seen as general information for all LINAK products.

## LINAK A/S



## GENERAL ASSEMBLY INSTRUCTIONS

Please read the following safety information carefully. Ensure that all staff who are to connect, mount, or use the actuator are in possession of the necessary information and that they have access to this assembly instruction.

Persons who do not have the necessary experience or knowledge of the product/products must not use the product/products. Besides, persons with reduced physical or mental abilities must not use the product/products, unless they are under surveillance or they have been thoroughly instructed in the use of the apparatus by a person who is responsible for the safety of these persons. Moreover, children must be under surveillance to ensure that they do not play with the product.



### Warnings

**Failure to comply with these instructions may result in accidents involving serious personal injury.**

It is important for everyone who is to connect, install, or use the systems to have the necessary information and access to the User Manual on [www.linak.com](http://www.linak.com).

- If there is visible damage on the product it must not be installed.
- If the control box / Twindrive makes unusual noises or smells, switch off the mains voltage immediately.
- The products must only be used in an environment that corresponds to their IP protection.
- The cleaners and disinfectants must not be highly alkaline or acidic (pH value must be 6 to 8).
- Irrespective of the load, the duty cycle stated in the data sheets, must NOT be exceeded.
- The DESKLINE® systems can only be used in push applications.
- The control box / Twindrive must only be connected to the voltage stated on the label.
- System not specified for pull must only be used in push applications.
- Fastening screws and bolts must be tightened correctly.
- Do not open the closing device on the Twindrive during operation.
- Specifications on the label must under no circumstances be exceeded.
- NOT TO BE OPENED BY UNAUTHORIZED PERSONNEL.
- Use only the actuator within specified working limits.
- Note that during construction of applications, in which the actuator is to be fitted, there must be no risk of personal injury, such as squeezing of fingers or arms.
- If irregularities are observed, the actuator must be replaced.
- If the actuator is used for pull in an application where personal injury can occur, the following is valid: It is the application manufacturer's responsibility to incorporate a suitable safety arrangement, which will prevent personal injury from occurring, if the actuator should fail.
- MEDLINE® & CARELINE® products are rated to operate at an altitude < 2000 m.



### Recommendations

**Failure to follow these instructions can result in the actuator being damaged or being destroyed.**

- Before you start mounting/dismounting, ensure that the following points are observed:
  - The actuator is not in operation.
  - The mains current supply is switched off and the plug has been pulled out.
  - The actuator is free from loads that could be released during this work.
- Before you put the actuator into operation, check the following:
  - The actuator is mounted correctly as indicated in the relevant user instructions.
  - The equipment can be freely moved over the actuator's whole working area.
  - The actuator is connected to a mains electricity supply/transformer with the correct voltage and which is dimensioned and adapted to the actuator in question.
  - Ensure that the voltage applied matches the voltage specified on the actuator label.
  - Ensure that the connection bolts can withstand the wear.
  - Ensure that the connection bolts are secured safely.
- During operation
  - Listen for unusual sounds and watch out for uneven running. Stop the actuator immediately if anything unusual is observed.
  - Do not side load the actuator.
  - Use only the actuator within the specified working limits.
  - Do not kick or step on the actuator.
- When the equipment is not in use
  - Switch off the mains supply or pull out the plug in order to prevent unintentional operation.
  - Check regularly the actuator and joints for extraordinary wear.
- Note: If the actuator is operated as a hand crank, it must be operated by hand, otherwise there is a risk of overloading the actuator and hereby damage the actuator.  
When changing the cables on a LINAK actuator, it is important that this is done carefully, in order to protect the plugs and pins.  
Please ensure that the plug is in the right location and fully pressed in before mounting the cable lid.



# DECLARATION OF INCORPORATION OF PARTLY COMPLETED MACHINERY

LINAK A/S  
Smedevænget 8  
DK - 6430 Nordborg

LINAK A/S hereby declares that LINAK DESKLINE® products, characterised by the following models and types:

Control Boxes	CBD6S
Linear Actuators	DB5, DB6, DB14, LA23, LA31
Lifting Columns	DL1A, DL2, DL4S, DL5, DL6, DL8, DL9, DL10, DL11, DL12, DL14, DL15, DL16, DL17, DL18, DL19, DL20, DL21, BASE1, LC1
Desk Panels	DPA, DPB, DPH, DPF, DPG, DPT, DP1CS, DPI
Wireless Controls	BP10
Frames and Feet	Kick & Click, DF2, DF3, DF4, DF5, DLF
Accessories	BA001, BLE2LIN, CHUSB, DESK Sensor, SLS, SMPS, USB2LIN, WiFi2LIN, DC Connector, RFRL

LINAK A/S hereby declares that LINAK HOMELINE® products, characterised by the following models and types:

Control Boxes	CBD6DC
Linear Actuators	LA10, LA18, LA40 HOMELINE, BASE1
Dual Actuators	TD4, TD5
Controls	BP10, HC10, HC20, HC40, HC50, HC60
Accessories	BA002, CP, BLE2DC, BLE2LIN, LED Light Rail, MD1, SMPS, WiFi2LIN

LINAK A/S hereby declares that LINAK MEDLINE® & CARELINE® products, characterised by the following models and types:

Control Boxes	CA10, CA20, CA30, CA40, CA63, CAL40, CB6, CB6S, CB6P2, CB8, CB9, CBJ2, CBJ Care, CBJ Home, CO41, CO53, CO61, CO65, CO71, COL50, OPS, PJ2
Linear Actuators	KA19, KA30, KA30 ICA, LA20, LA23, LA24, LA24 ICA, LA27, LA28, LA29, LA30, LA31, LA34, LA40, LA42, LA44
Lifting Columns	BL1, LC1, LC3
Controls	ABL, ACC, ACK, ACO, ACOD, ACOM, ACL, DP, DPH, FS, FS3, FPP, HB30, HB70, HB80, HB100, HB190, HB200, HB400, HD80, HL70, HL400, SC01
Accessories	BA15, BA16, BA18, BA19, BA22, BAJ, BAJL, BAL40, BAL50, CH01, CHJ2, CHL40, CHL50, DJB, LIN2OB, MJB2, MJB5 Plus, Massage Motor, PJB4, QLC12, SLS, SMPS10, UBL, UBL2, UBL4 Motion, USB-A Power Adapter

LINAK A/S hereby declares that LINAK TECHLINE® products, characterised by the following models and types:

Linear Actuators	LA12, LA14, LA21, LA23, LA25, LA30, LA33, LA35, LA36, LA37, LA73, LA76, LA77
Lifting Columns	LC3 IC
Accessories	FMB

comply with the following parts of the Machinery Directive 2006/42/EC, ANNEX I, Essential health and safety requirements relating to the design and construction of machinery: 1.5.1 Electricity supply

The relevant technical documentation is compiled in accordance with part B of Annex VII and this documentation or part hereof will be transmitted by post or electronically to a reasoned request by the national authorities.

**This partly completed machinery must not be put into service until the final machinery into which it is to be incorporated has been declared in conformity with the provisions of the Machinery Directive 2006/42/EC where appropriate.**

Nordborg, 2026-05-18

*John Kling*

## LINAK A/S

John Kling, B.Sc.E.E., Certification and Regulatory Affairs  
Authorised to compile the relevant technical documentation

Original declaration

**LINAK**®   
WE IMPROVE YOUR LIFE



## Important information

LINAK® products, within the scope of this manual, are not classified as medical electrical equipment or systems, nor do they fall within the scope of the EU Medical Device Directive/Regulation or other similar national regulations. The products are components to be built into a piece of medical electrical equipment by a manufacturer.

To support the assessment and certification task of the complete medical electrical equipment or system worldwide, LINAK provides certification, on a component level, according to the IEC 60601-1, (Medical electrical equipment – Part 1: General requirements for basic safety and essential performance) as recognised components by NRTL (Nationally Recognized Testing Laboratories).

Description of the various signs used in this manual:



### Warnings

Failure to comply with these instructions may result in accidents involving serious personal injury.



### Recommendations

Failing to follow these instructions can result in product damage.

### Please read the following safety information carefully:

Ensure that all staff who are to connect, mount, or use the actuator system are in possession of the necessary information and that they have access to these assembly instructions.

Persons who do not have the necessary experience or knowledge of LINAK products should not use these. Moreover, persons with reduced physical or mental abilities must not use the products, unless they are under surveillance or they have been thoroughly instructed in the use of the equipment by a person who is responsible for the safety of these persons. Moreover, children must be under surveillance to ensure that they do not play with the product.

Please be aware that LINAK has taken precautions to ensure the safety of the actuator system. The manufacturer/OEM is responsible for the overall approval of the complete application.



LINAK recommends to use the actuators in push applications rather than pull applications.



LINAK actuators are not to be used for repeated dynamic push-to-pull movements.

For general pull applications or repeated dynamic push-to-pull movements in the application, please contact LINAK A/S if in doubt.

LINAK actuators and electronics generally fall outside the IEC 60601-1 definition of applied parts and are not marked as such.

However, assessing the risk whether actuators and electronics can unintentionally come into contact with the patient, determines that they are subject to the requirements for applied parts. All the relevant requirements and tests of the standard are carried out as part of the IEC CB\* Scheme/NRTL\*\* assessment.

\* CB: Certification Body

\*\*NRTL: Nationally Recognised Testing Laboratory



## General warnings

**Failure to comply with these instructions may result in accidents involving serious personal injury:**



The medical device manufacturer is responsible for the incorporation of a suitable safety arrangement, if the actuator or lifting column is used for pull in an application where personal injury can occur, which will prevent personal injury from occurring in case of actuator failure.



Note that during construction of applications, in which the actuator is to be fitted, there must be no possibility of personal injury, for example the squeezing of fingers or arms.



The plastic parts in the system cannot tolerate cutting oil.



Assure free space for movement of the application in both directions to avoid a blockade.



The application and actuators are only to be operated by instructed personnel.



In applications with spline function, the blockage by an obstacle when the application is moving inwards, the removal of the obstacle will cause the load to drop until the spindle hits the nut.



Do not turn the outer tube.



Do not use chemicals.



Inspect the actuator system regularly for damage and wear.



Do not expose LINAK actuator system components to high intensity ultraviolet radiation disinfection lamps. This may damage the enclosure, supporting parts and cables.















LINAK actuators and electronics are not designed for use within the following fields:

- In the presence of a flammable anesthetic mixture with air or with oxygen or nitrous oxide
- Planes and other aircrafts
- Explosive environments
- Nuclear power generation



If faults are observed, the products must be replaced.



-  A LINAK control box, actuator and accessory component must, in the final application, be placed where it is not exposed to any impact. This is to prevent damage if a passer-by accidentally hits it with an object or when cleaning the floor with a broom or a mop. On a medical bed e.g. this might be underneath the mattress support platform. If necessary to mitigate this risk, additional protection might be required.
-  To avoid unintended movement, prevent foreign objects or persons from unintentionally activating a footswitch or a hand control at any time, for instance during normal use or maintenance.
-  If there is visible damage on the product it should not be installed.
-  If the actuator system makes unusual noise or smells, switch off the mains voltage immediately and disconnect batteries, if applicable.
-  The products must only be used in an environment that corresponds to their IP protection class.
-  The cleaners and disinfectants must not be highly alkaline or acidic (pH value 6-8). See cleaning section.
-  Irrespectively of the load, the duty cycle stated on the product label must NOT be exceeded.
-  The control box must only be connected to the voltage stated on the label.
-  Systems not specified for pull must only be used in push applications.
-  Fastening screws and bolts must be tightened correctly.
-  Specifications on the product label must under no circumstances be exceeded.
-  NOT TO BE OPENED BY UNAUTHORISED PERSONS.
-  Only use the actuator within specified working limits.



Be aware that during the design of medical devices, the risk of personal injury (for instance squeezing of fingers or arms) must be minimised.



If irregularities are observed, the actuator must be replaced.



All cables must be mounted in such a way that they are not trapped or exposed to tension or sharp objects when the application is moved in different directions.



## General recommendations

### Failing to follow these instructions may result in actuator system damage:



The duty cycle printed on the actuator system label must always be respected. If exceeded, there is a risk that the actuator system is damaged. Unless otherwise specified on the label, the duty cycle is max. 10%, max. 2 min. in use followed by 18 min. not in use.



All detachable connections between components must be locked by the cable locking mechanism - when applicable.



It is recommended to have options like quick release, manual lowering or similar built into the system in case of power loss or system failure or if movement of the system is critical. After service it is recommended to test the system for correct functionality before it is put back into operation.



Prior to assembly/disassembly, ensure that the following points are observed:

- The actuator system is not in operation.
- The mains current supply is switched off and the plug has been pulled out.
- Batteries - if applicable - may also power the system.
- Actuators are free from loads that could be released during this work.



Prior to operating the actuator system, check the following:

- Actuator system components are correctly mounted as indicated in the product-specific user instructions.
- The equipment can be operated in its entire intended range of movement.
- Ensure that the load-supporting bolts can withstand the wear.
- Ensure that the load-supporting bolts are secured safely.



During operation:

- Listen for unusual sounds and watch out for uneven movement. Stop the actuator system immediately if anything unusual is observed.
- Do not sideload the actuator.
- Do not step on or kick any LINAK component.



When the equipment is not in use:

- Switch off the mains supply or pull out the plug in order to prevent unintentional operation.



Cables and plugs:

- It is important to remove the transport plastic bag before using the cable.
- When changing the cables on a LINAK® actuator system, it is important that this is done carefully in order to protect the plugs and pins.
- Please ensure that the plug is in the right location and properly inserted before the cable lid is mounted.



## General Regulatory Considerations

Certain LINAK components are not individually certified under IEC 60601-1 due to incomplete constructional features that prevent full compliance. Specifically, products without enclosures, such as for instance those exposing printed circuit boards or mechanical parts, do not meet the safety requirements outlined in the standard.

Medical equipment must comply with strict regulations to ensure the safety of patients and healthcare professionals.

When LINAK components are integrated into a medical device, it is the responsibility of the medical device manufacturer to ensure that these components are adequately enclosed.

Ultimately, the medical device manufacturer is responsible for ensuring that the final product complies fully with IEC 60601-1 and all other applicable standards.

## General warranty periods

As general warranty period, LINAK provides 5 years (60 months) warranty on MEDLINE and CARELINE products used in beds and medical applications. If MEDLINE and CARELINE products are used in other applications, they will be covered by 1½ years (18 months) warranty.

Batteries are covered by a specific product warranty of 12 months.

External products that are not manufactured by LINAK AVS: 12 months are added to the warranty period, for instance for transportation and stocking. Relabelling of these products only takes place, if the production date exceeds one year from the date of dispatch to the customer.

If there is any doubt whether returned products are covered by the warranty, they are covered by the warranty. Please use the date of the control box or actuator as reference, if possible.



## Electromagnetic Compatibility (EMC)

### EMC Warnings



#### **Electromagnetic compatibility – general**

LINAK® actuator systems bear the CE marking as an attestation of compliance with the EMC Directive 2014/30/EU. The systems are designed to meet all requirements of applicable standards and have been tested to meet IEC 60601-1-2 requirements.

##### Emission:

LINAK Actuator Systems are CISPR 11, Group 1, Class B products, comply with IEC 61000-3-2, Class A and IEC 61000-3-3.

##### Immunity:

Test levels are according to Professional Healthcare Facility and Home Healthcare Facility Environment.

Electromagnetic phenomena are evaluated on a system level, with the actuator connected to a LINAK control box and accessories.

LINAK always recommends to perform verification tests on the final medical device.



#### **Electromagnetic compatibility – third party components**

Use of accessories, transducers and cables other than those specified by LINAK could result in increased electromagnetic emissions or decreased electromagnetic immunity of the actuator system and result in improper operation.



#### **Electromagnetic compatibility – interference with other equipment in general**

Use of the actuator system adjacent to or stacked with other equipment should be avoided as this could result in improper operation. If such use is necessary, the actuator system and the other equipment should be observed to verify that they are operating properly.

If the user notes unusual behavior of the actuator system, in particular if such behaviour is intermittent and associated with the standing right next to mobile phones, microwaves and radio broadcast masts, this could be an indication of electromagnetic interference.

If such behaviour occurs, try to move the actuator system further away from the interfering equipment.



#### **Electromagnetic compatibility – interference with other equipment, RF communications**

RF communication equipment (e.g. RFID, wireless RF etc. including peripherals such as antenna cables and external antennas) should be used at a distance no closer than 30 cm (12 inches) to any part of the actuator system. This also applies to cables specified by the manufacturer. Otherwise, a performance degradation of this equipment could result.



## EMC responsibilities for LINAK actuator systems

LINAK verifies the EMC performance of each LINAK product and approves them individually. The LINAK products can be combined and integrated into many different systems. LINAK also verifies the system EMC performance on commonly used combinations.

LINAK has certificates in accordance with applicable standards for each product and provides the customers, who are building the application and integrating these products into systems (systems with control box, actuators, cables, batteries, etc.), with these certificates.

However, EMC testing of LINAK products in generic LINAK systems is not made in an environment that corresponds to the specific application environment which differs from the generic testing environment. There will be differences that can affect the EMC performance in the specific target application.

The customer is responsible for qualifying and approving the complete application including the LINAK system.

### Regulatory standard

LINAK products, being components to be incorporated by a Manufacturer [definition: IEC 60601-1 ed.3.1, cl. 3.55] into Medical Electrical Equipment [definition: IEC 60601-1 ed.3.1, cl. 3.63], are tested concerning the EMC phenomena according to the Collateral Standard IEC 60601-1-2 ed. 4.1.

IEC 60601-1-2 ed. 4.1 sets forth the requirements for the electromagnetic compatibility of Medical Electrical Equipment, ensuring that devices operate safely and effectively within their intended environments. Compliance with this standard is essential to minimize electromagnetic interference and maintain the integrity and performance of Medical Devices.

Furthermore, IEC 60601-1-2 ed. 4.1 states:

“This collateral standard recognizes that the Manufacturer has the responsibility to design and perform Verification of Medical Electrical Equipment and Medical Electrical Systems to meet the requirements of this Collateral Standard and to disclose information to the Responsible Organization or Operator so that the Medical Electrical System will remain safe throughout its Expected Service Life.”

### Qualification process of a new application

The qualification process for a new application is normally done in cooperation between the customer and LINAK. LINAK provides the relevant support, competence and documentation needed for the customer's overall development plan and test plan for the specific application.

The driver of the qualification process is the customer who has the ultimate application responsibility (MDS). The customer identifies and specifies the needed testing based on many different parameters (experience, risk management, requirements from standards, etc.).

In many cases, the customer is establishing and verifying tests early in the project to ensure that the approval process has a low risk of failing when tested in the approval institute.

The customer identifies which tests to make and when they are to be performed in the project to mitigate the risk of failure in the approval process which also includes EMC testing.



## Electrostatic discharge (ESD)

LINAK® considers ESD to be an important issue and years of experience have shown that equipment designed to meet the levels specified in standards might be insufficient to protect electronic equipment in certain environments.

### 1. Handling and mounting electrostatic discharge sensitive devices (ESDS devices).

- Handling of sensitive components shall only take place in an ESD Protected Area (EPA) under protected and controlled conditions.
- Wrist straps and/or conductive footwear (personal grounding) shall always be used when handling ESDS devices.
- Sensitive devices shall be protected outside the EPA by the use of ESD protective packaging.

### 2. Responsibility LINAK/customer

- ESDS devices must under no circumstances, during transport, storage, handling, production or mounting in an application, be exposed to harmful ESD.
- LINAK can only guarantee the lifetime of ESDS devices if they are handled in the same way from production at LINAK A/S until they are mounted in the manufacturer's application. It is therefore important that the ESDS devices are not removed from the ESD protected packaging before they are physically within the EPA area at the customer premises.

### Please refer to EN61340 for further information:

EN61340-5-1, Electrostatics - Protection of electronic devices from electrostatic phenomena - General requirements

EN61340-5-2, Electrostatics - Protection of electronic devices from electrostatic phenomena - User guide



## RF transmitter/receiver properties

Some LINAK products emit RF-power by intention for communication purposes.

Frequency band of transmission: 2402 MHz - 2480 MHz

Type: Bluetooth® Low Energy

Modulation: GFSK

Maximum Effective Radiated Power (ERP): 10 dBm

## FCC and IC Statements

For RF-emitting products (e.g. Bluetooth®, Wi-Fi) intended to be used on the North American continent, the following applies:

### FCC statement

NOTE: This equipment has been tested and found to comply with the limits for a Class B digital device, pursuant to part 15 of the FCC Rules. These limits are designed to provide reasonable protection against harmful interference in a residential installation. This equipment generates uses and can radiate radio frequency energy and, if not installed and used in accordance with the instructions, may cause harmful interference to radio communications. However, there is no guarantee that interference will not occur in a particular installation. If this equipment does cause harmful interference to radio or television reception, which can be determined by turning the equipment off and on, the user is encouraged to try to correct the interference by one or more of the following measures:

- Reorient or relocate the receiving antenna.
- Increase the separation between the equipment and receiver.
- Connect the equipment into an outlet on a circuit different from that to which the receiver is connected.
- Consult the dealer or an experienced radio/TV technician for help

Changes or modifications not expressly approved by the party responsible for compliance could void the user's authority to operate the equipment.

This device complies with Part 15 of the FCC Rules. Operation is subject to the following two conditions:

- (1) this device may not cause harmful interference, and
- (2) this device must accept any interference received, including interference that may cause undesired operation.

### IC statement

This device contains licence-exempt transmitter(s)/receiver(s) that comply with Innovation, Science and Economic Development Canada's licence-exempt RSS(s). Operation is subject to the following two conditions:

- (1) This device may not cause interference.
- (2) This device must accept any interference, including interference that may cause undesired operation of the device.





















L'émetteur/récepteur exempt de licence contenu dans le présent appareil est conforme aux CNR d'Innovation, Sciences et Développement économique Canada applicables aux appareils radio exempts de licence. L'exploitation est autorisée aux deux conditions suivantes :

- (1) L' appareil ne doit pas produire de brouillage;
- (2) L' appareil doit accepter tout brouillage radioélectrique subi, même si le brouillage est susceptible d' en compromettre le fonctionnement.



## Symbols

The following symbols are used on the LINAK product labels, where applicable:

	IEC 60417-5172: Class II equipment		Compliance to all relevant EC directives
	IEC 60417-5840: Applied part type B		UK Conformity Assessment
	IEC 60417-5019: Class I equipment Protective earth; protective ground		Regulatory compliance mark: The Australian Safety/EMC Regulations
	IEC 60417-5002: Positioning of cell		Alternating current
	ISO 7000-0434A: Caution, consult accompanying document		Direct current
	ISO 7000-1641 Operating instructions		Reduced ETL recognised component mark for Canada and the United States. X: The mark is always accompanied by a control number of 6 or 7 figures. For complete description, see ETL marking on next page.
	Electronics scrap		
	Electronics scrap		Bluetooth®
 Li-ion	Recycle		Japanese TELEC
	Recognised Component mark for Canada and the United States		
	PSE diamond mark		
	PSE circle mark		



## Electrical Testing Laboratories (ETL) marking

Due to space limitations, the complete ETL marking demands are not represented on the marking plates.

The full ETL recognised component markings are shown here:



**C/N 120690**  
 Conforms to ANSI/AAMI Std. E560601-1  
 Cert. to CSA Std. C22.2 No. 60601-1



**C/N 4008004**  
 Conforms to ANSI/AAMI Std. E560601-1  
 Cert. to CSA Std. C22.2 No. 60601-1



**C/N 4008838**  
 Conforms to ANSI/AAMI Std. E560601-1  
 Cert. to CSA Std. C22.2 No. 60601-1



**C/N 9901916**  
 Conforms to ANSI/AAMI Std. E560601-1  
 Cert. to CSA Std. C22.2 No. 60601-1



**C/N 4008005**  
 Conforms to ANSI/AAMI Std. E560601-1  
 Cert. to CSA Std. C22.2 No. 60601-1



**C/N 4008671**  
 Conforms to ANSI/AAMI Std. E560601-1  
 Cert. to CSA Std. C22.2 No. 60601-1



**C/N 4008003**  
 Conforms to ANSI/AAMI Std. E560601-1  
 Cert. to CSA Std. C22.2 No. 60601-1



**C/N 4008623**  
 Conforms to ANSI/AAMI Std. E560601-1  
 Cert. to CSA Std. C22.2 No. 60601-1



**C/N 4009507**  
 Conforms to ANSI/AAMI Std. E560601-1  
 Cert. to CSA Std. C22.2 No. 60601-1



## Batteries

To comply with the EU Battery Regulation (EU) 2023/1542, battery-related information is provided through this QR code.



Scanning the QR code gives access to battery identification details, as well as safety and environmental information available on the LINAK website.

This information must also be included in the end-product user manual.

## General battery warnings



Handle batteries carefully. Do not short circuit the battery.



Avoid continuous battery discharge when the medical device is not in use, as this may cause lead sulphate formation, which, if left in this state for too long, will irreversibly damage the battery.



LINAK battery packs may emit flammable gases. Do not expose the battery packs to fire or equipment that emits sparks. Moreover, do not store the battery in a closed environment or incorporate it into a closed structure of an enclosure as this may cause an explosion, fire, equipment damage, or injury.



Handle tools carefully and do not wear jewelry when handling batteries. A short-circuit of the battery terminals can cause burn injuries, damage or trigger explosions.



Only connect LINAK batteries to compatible chargers.



LINAK battery packs contain toxic substances. If the internal battery fluid leaks out and gets onto skin or clothing, make sure it is washed off with clean water. Moreover, if the fluid gets into the eyes, rinse them immediately with clean water and seek medical assistance.



Do not use or store LINAK battery packs in places where the ambient temperature exceeds 50 °C, such as inside a hot automobile, in direct sunlight, or in front of a stove or a source of intense heat. Doing so can shorten the battery life, lower its performance level, cause the battery to leak fluid, explode, cause fire, or be damaged.



Applications where batteries serve as backup and not as the main power source should always be connected to mains whenever possible.



## Lithium ion batteries

Li-Ion batteries are moving in the direction of minimising the physical size and, at the same time, increasing the capacity. This gives a very compact battery with a high energy concentration. It also increases the risk of thermal runaway (see note below) due to internal short circuits.

The general use of Li-Ion batteries has increased, and the inherent risk of thermal runaway has led to stricter rules within the transport industry, specifically air transport with tightened restrictions on the quantity, handling, and storage of specific products.

The OEMs and consumers must recognise that although safe to use, Li-Ion cells always have a very small risk of thermal runaway. The risk could be as little as 1 PPM or even less.

LINAK currently bases our Li-Ion battery design on cell types with an industry-proven history (e.g. electric cars). The use of well-proven cell technology reduces the risk of thermal runaway, but it does not eliminate it. LINAK has completed activities to reduce this risk and the complete battery package is approved in accordance with UL.

An external, internationally recognised expert has also reviewed the design to ensure that it is manufactured according to the latest recommendations. Further to that, we only use cells from well-recognised manufacturers.

LINAK recommends that when using Li-Ion batteries, the customers should carry out proper risk analysis on their application. The risk analysis must also take into consideration that these products are not mounted in positions where they are in direct contact with flammable materials.

LINAK Li-Ion batteries have no greater risk of thermal runaway than other Li-Ion cells from well-recognised manufacturers within the market. Therefore, LINAK cannot take responsibility for any failures that occur due to a failure that is inherent in the nature of Li-Ion batteries.

If any of the Li-Ion batteries built into LINAK products are found to be defective under warranty, LINAK will provide the OEM with a new product. LINAK explicitly disclaims all other remedies. LINAK shall not in any event be liable under any circumstances for any special indirect punitive incidental or consequential damages or losses arising from any incident related to the inherent risk of thermal runaway in the Li-Ion cell and any use of LINAK products. Moreover, LINAK explicitly disclaims any responsibility for profit loss, failure to realise expected savings, any claim against our customer by a third party, or any other commercial or economic losses of any kind, even if LINAK has been advised of the possibility of such damages or losses.

Note: 'Thermal runaway' is overheating of a cell, and it could lead to a small fire and smoke from the cell.













## Transportation

The lithium ion batteries must be packed and transported in accordance with applicable regulations. Always ask your local transportation provider how to handle the transportation of lithium ion batteries.





Please see the general assembly instructions and the mounting section for detailed information.









## Warnings

-  When using Li-Ion batteries with patient lift control boxes, loss of power might happen due to the battery deep discharge protection. This will only happen in case of continuous battery use despite warnings. In this event, there may be no warning, and the application may not be able to move when expected.
-  In his risk analysis, the customer must take into consideration how to assure alternative means to make movement, for instance quick release or manual lowering.
-  Do not open the battery housing as damaging the cell or circuitry may develop excessive heat.
-  If product caution is not clearly visible at low light intensity, read the product label instructions symbol. A warning must be included in the application manufacturer manual for the medical device.
-  The application manufacturer must test the application and ensure that intentional and unintended operations do not exceed the battery specification limits.
-  Defective or damaged Li-Ion batteries are not allowed for transportation.
-  For safety reasons, please adhere to the indicated charging and operation temperature.
-  In case the battery is too hot, disconnect it, evacuate the room, and wait for 2 hours before taking further steps.
-  Mounting instructions must be followed in order to avoid exposing batteries to water.
-  In general, recharging of batteries must take place every 12 months. However, please note:
  - New Li-Ion batteries, shipped from LINAK are in a deep-sleep state, where the self-discharge is very little
  - When mounted in an application, LINAK Li-Ion batteries wake up, resulting in a higher rate of charge, depending on the application/system
  - Application manufacturer must consider this idle consumption for his specific system and make precautions to avoid discharged batteries.
  - Contact your LINAK sales team for further information
-  If batteries are to be shipped by air, they shall not be charged to more than 30%
-  Disposal of the battery takes place in accordance with local regulations.

## Recommendations

-  Do not exceed the storage temperature as it will shorten the product life and performance.
-  Allow the battery to settle to room temperature before use.
-  Lithium ion batteries are not intended for use in outdoor applications and indoor pool environments.
-  If the battery is completely discharged, then recharge the battery before storage.
-  Always use correct LINAK charger

## DO NOT:

-  Heat or burn the batteries.
-  Expose the batteries to high impact/excessive force.
-  Crush or puncture the batteries.
-  Use batteries with signs of damage or corrosion.
-  Charge or store the batteries near combustible material.
-  Exceed IP-ratings.
-  Overcharge or fully discharge the batteries.

## Safety feature

Lithium ion batteries contain several mechanisms to protect themselves from being damaged due to excessive use. In case of overheating, the device will activate a thermal protection. No power output will be available until the temperature is again within normal operating range.

Overheating may occur by extensive use at high temperatures or when exceeding the duty cycle (see product label).

## Lead acid batteries

### Maintenance of batteries

Prior to first use of LINAK® batteries, please make sure that they are charged at least 24 hours and if possible even longer for proper functioning and prolonging the battery lifetime.

### Replacement of batteries

The batteries must only be replaced by the same type of batteries or mechanical and electrical equivalent types. The batteries must be new or maintained by means of charging at least every 6 months. The batteries, which make a set, must be supplied with identical production codes.

Production code mismatch may lead to a severely reduced lifetime expectancy.

Before mounting, ensure that the battery set is correctly connected, compare with the drawing in the battery room and check that no connectors are loose.

### Warnings in connection with battery replacement



Please observe the following maintenance, replacement, and disposal requirements to ensure a safe and reliable operation.



The batteries are to be replaced after 4 years at the latest. Perhaps earlier, depending on the pattern of use. Frequent and high-powered discharges reduce the battery life. For an optimum lifetime, the product must be connected to the mains voltage as often as possible. It is recommended that the batteries are to be charged for at least every 6 months - otherwise the batteries will have reduced capacity due to self-discharge. It is recommended to test the battery function at least once every year.



The battery compartment is hermetically separated from the electronics compartment. When replacing the batteries this separation must not be damaged or modified as this may allow penetration of battery gas into the electronics compartment with risk of explosion.



When replacing batteries in waterproof products (IPX5 and IPX6), precautions must be taken that the sealing material (silicone ring or joint filler) is not damaged and that it is correctly placed in the groove. Hereafter, the screws in the cover are to be fastened with approx. 1 Nm. If necessary, replacement sealing is available at LINAK.



The battery compartment is supplied with ventilation that ensures correct and necessary airing of the battery compartment. This airing must not be blocked or covered as a positive pressure may occur with risk of explosion.



If the product has been exposed to mechanical overload (lost on the floor, collision/squeezing in the application or a powerful stroke), the product must be sent to an authorised workshop for control of the hermetic separation between the battery and electronics compartment.

### Disposal

Lead acid batteries must be disposed of in the same way as car batteries. Alternatively, they may be returned to LINAK.

## System description

LINAK® actuators, lifting columns and electronics have been developed for use in all places where a linear movement is required.

### LINAK products can for example be used for:

- Adjustment of beds
- Patient lifts within the care and hospital sector
- Adjustment of dentist chairs/gynaecological chairs

## Connecting the system

Do not connect the mains cable until all actuators and hand controls have been connected to the control box.

Start by connecting the hand control to the control box. The connection in the control box is marked with "HB".

Connect the different actuators to the different channels on the control box. Each channel is marked with a number (e.g. "1", "2", "3".....).

Check that all plugs are well connected and firmly pushed into the connector. Due to the fact that LINAK® control boxes are designed for a high IP degree, a firm force can be required.

Connect the mains cable.

The actuators can now be operated by pressing a button on the hand control button.

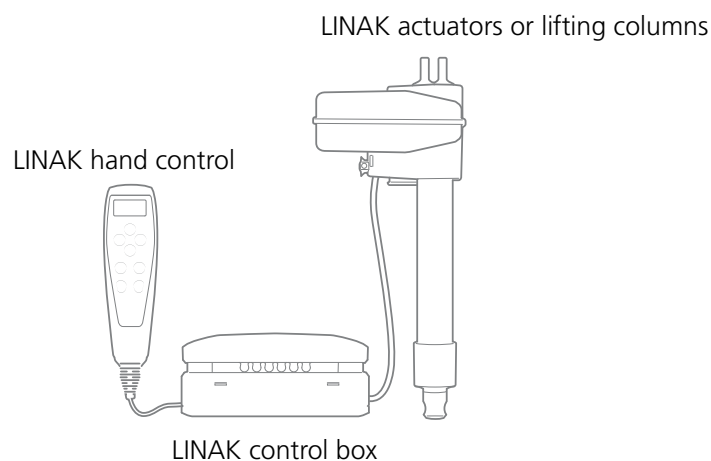

Any non-detachable power supply cord with mains plug is considered to be the disconnecting device.

Charging is only allowed in dry environment, and the appliance inlet must be thoroughly dried before connecting to mains.

## General mounting of actuators

Do not use any other screws for the mounting brackets than those recommended by LINAK®. If longer screws are used, they will come into contact with the inner parts of the actuator. This will result in an irregular operation or even damage the actuator.

**Be aware of the following during mounting and refer to the drawings below:**

- Fixed to protect it against torque and bending.
- Fixed so that it is restrained, but free to move on its mountings.
- Fixed in brackets, which can take up the torque reaction.
- Mounted at right angles so that the right angle requirement is observed.
- Mounted with correct bolt dimension.
- Mounted with bolts and nuts made of high quality steel grade (for example 10.8). No thread on bolts inside the back fixture or the piston rod eye.
- Bolts and nuts must be protected from being able to fall out.
- Inspect the actuator for damage before mounting. A damaged actuator must not be mounted. Check for instance for damaged packaging.
- Do not use a too high torque when mounting the bolts for the back fixture or the piston rod eye

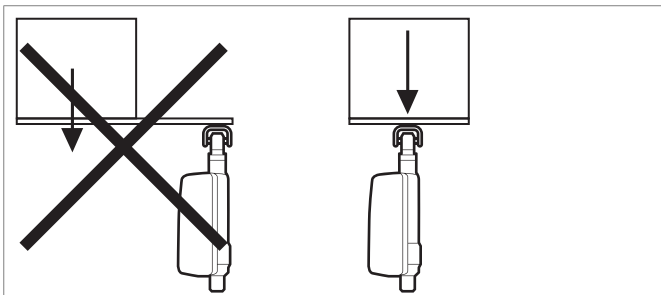

Figure 1

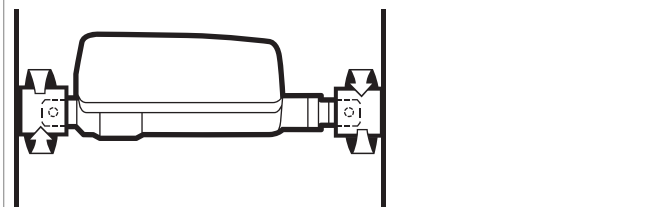

Figure 2

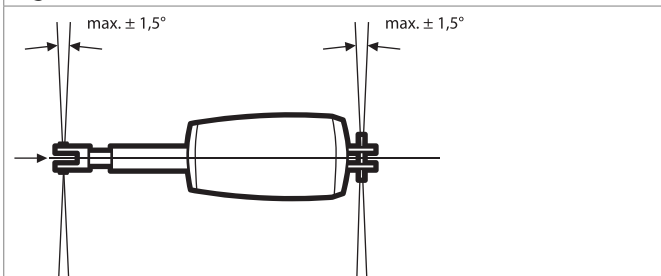

Figure 3

## General mounting of control boxes

- If applicable, the mounting screws on the control box must be tightened with a maximum torque of 1 Nm
- If applicable, the mounting surface to which the control box is attached should have a surface evenness better than  $\pm 0.5$  mm
- Systems must not be installed/deinstalled while in operation
- Nuts and bolts must be made of steel
- Nuts and bolts must be tightened securely
- For control boxes with earth connection (Class 1), the nut must be tightened with a torque of 1-1.2 Nm

## General mounting of accessories

- The mounting screws on accessories must be tightened with a maximum torque of 1 Nm
- The mounting surface to which the accessory is attached should have a surface evenness of more than  $\pm 0.5$  mm
- Systems must not be installed/deinstalled while in operation
- Nuts and bolts must be made of steel
- Nuts and bolts must be tightened securely

## General mounting of controls

- The mounting screws on the controls must be tightened with a maximum torque of 1 Nm
- The mounting surface to which the accessory is attached should have a surface evenness of more than  $\pm 0.5$  mm
- Systems must not be installed/deinstalled while in operation
- Nuts and bolts must be made of steel
- Nuts and bolts must be tightened securely



## General environmental conditions

### Operating, storage and transport

Operating temperature	+5 °C to +40 °C
Relative humidity	20% to 80% - non-condensing
Atmospheric pressure	700 to 1060 hPa (Rated to be operated at an altitude $\leq$ 3000 m)
Storage temperature	-10 °C to +50 °C
Relative humidity	20% to 80% - non-condensing
Atmospheric pressure	700 to 1060 hPa (Rated to be stored at an altitude $\leq$ 3000 m)
Transport temperature	-10 °C to +50 °C
Relative humidity	20% to 80% - non-condensing
Atmospheric pressure	700 to 1060 hPa (Rated to be transported at an altitude $\leq$ 3000 m)
These values apply unless specified otherwise in the product-related texts.	



## Information on start-up, deinstallation and operation

### Before installation, deinstallation or troubleshooting

- Stop the actuator/lifting column.
- Switch off the power supply or pull out the mains plug and pull out the plug to the actuator/lifting column.
- Relieve the actuator/lifting column of any loads, which may be released during the work.

### Before start-up

- Make sure that the system has been installed as instructed in the relevant product manual.
- The individual parts (actuator/lifting column/hand controls etc.) must be connected before the control box is connected to the mains.
- Make sure that the mains voltage to be connected to the product or the system is the one stated on the label.
- The equipment can be moved freely over the whole working area of the actuator/lifting column.
- Check correct function after mounting.
- The actuator/lifting column must not be loaded in excess of the values indicated in the specifications on the product label.
- The duty cycle noted on the product label must always be observed. Otherwise there is a risk of product damage. Exceeding the duty cycle will result in a dramatic reduction of the system lifetime.
- Unless specified otherwise on the product label, the duty cycle is max. 10%, max. 2 minutes in use followed by 18 minutes not in use.
- The actuator/lifting column system may only be used in an environment corresponding to the IP rating of the system. LINAK products are marked with the actual IP rating on the label.
- If the actuator is assembled in the application and is exposed to push or pull during transportation, the actuator can be damaged.
- If any individual parts are suspected to be damaged, do not install the parts, but return them for inspection/service.

### During operation

- Check for unusual sounds and irregular movement. Stop the actuator/lifting column immediately if anything unusual is observed.
- If the control box makes unusual noises or smells, switch off the mains voltage immediately and the external battery, if any.
- Take care that the cables are not damaged.
- Unplug the mains cable on mobile equipment before it is moved.



## Cleaning

The products can be cleaned as described in the following according to their IP protection stated on the product label.

The IP code specifies the protection degree provided by the enclosures. For most products, only the protection against ingress of water (second characteristic numeral) is specified, ingress of solid foreign objects or dust (first characteristic numeral) is not specified and therefore replaced by the letter X in the code. However, it should be noted that compliance with the requirements of IEC 60601-1 automatically allows to rate the medical equipment as IP2X because the requirements of IEC 60529 for this rating are the same as the accessibility requirements.

IP protection	Cleaning instructions
IPX0	Clean with a damp cloth
IPX1	Clean with a damp cloth
IPX2	Clean with a damp cloth
IPX3	Clean with a damp cloth
IPX4	Clean with a damp cloth
IPX5	Wash with a brush and water, but not water under pressure
IPX6	Wash with a brush and water. The water can be under pressure, but the system must not be cleaned directly with a high pressure cleaner. Max. 20 °C
IPX6 Washable according to IEC 60601-2-52	Clean by the use of wash tunnels according to IEC 60601-2-52
IPX6 Washable DURA™	Clean by the use of wash tunnels according to IEC 60601-2-52, extended washing cycle test

To avoid degreasing of the piston rod, the actuator should be retracted to minimum stroke and without load before washing.

## Cleaning warnings



The systems must not be sprayed directly with a high pressure cleaner.



Interconnecting cables must remain plugged in during cleaning to prevent water ingress.



Cleaning with a steam cleaner is not permitted



UV cleaning is not permitted.

## IPX6 Washable

LINAK® washable products frequently undergo a fully regulated washing test.

At LINAK, 'IPX6 Washable' means that the products conform only to this test.

### Standard washing procedure

- Reference:** The standard IEC 60601-2-52 newest revision, which includes special demands to fundamental safety and relevant functional characteristics for hospital beds. The demands for the washing process are described in the German "Maschinelle Dekontamination" from the organisation AK-BWA (Arbeitskreis Bettgestell- und Wagen-Dekontaminationsanlagen).
- Description:** At LINAK, the washing test takes place in an instrument washing machine, which is fitted and programmed in such a way that it duplicates the process used in a typical hospital installation for the cleaning of beds and other medical equipment. During the test, the products are exposed to both thermal and chemical effects. To avoid degreasing of the piston rod, the actuator should be retracted to minimum stroke and without load before washing.
- Preparation:** As plastic materials to a larger or lesser degree change characteristics and shape with time and climatical exposure, an ageing of the products is carried out first. The conditions for ageing are 65 °C +/- 2 °C in normal dry air for 10 days followed by a minimum of 16 hours at room temperature before the washing process starts.
- Water:** Degree of hardness, no more than 5° dH and no demineralised water.
- Detergents:** **LINAK recommends the following products:**  
 Sekumatic FDR or FRE from Ecolab  
 Neodisher Dekonta from Dr. Weigert  
 Thermosept NDR from Schülke or similar with a pH-value of 5 - 8 and in a concentration of 0.5 %



## Rinsing aids

### LINAK® recommends the following products:

- Sekumatic FKN from Ecolab
- Neodisher BP or TN from Dr. Weigert
- Thermostept BSK from Schülke or similar with a pH-value of 5 - 8 and in a concentration of 0.2 %.

### Demands to chemicals:

- They must not contain caustic solutions
- They must not change the surface structure or adhesive properties of the plastic
- Must not break down grease

### LINAK washing profile according to IEC 60601-2-52

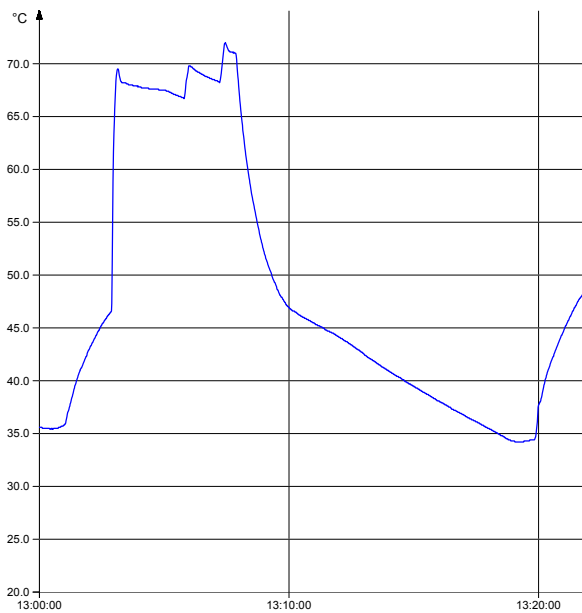

### LINAK washing machine



## IPX6 Washable DURA™

### Description of washing test

LINAK washable products frequently go through a fully controlled washing test. The LINAK term “IPX6 Washable DURA” signifies that the products conform exclusively to this test.

The “IPX6 Washable DURA” washing test is used to ensure that products that are rated “IPX6 Washable DURA” comply with the agreed terms and conditions. This washing test differs from the norm EN60601-2-52 as the products are not aged and each washing cycle is followed by a 30 minute cooling process.

Further information regarding the washing process can be found in the German document “Maschinelle Dekontamination” from the organisation AK-BWA.

**Estimated time consumption:** Approximately 1 month.

**Amount of samples:** During the development process, the number of tested samples is in accordance with GP082. During running production, the number of tested samples complies with UM-41-22-001.

**General:** The process applies to the IPX6 Washable DURA system.

**Test conditions:**

- The units are not aged.
- Products with adhesive foils must be hardened before ageing.
- The hardening time depends on the used adhesive, but is typically 3 days at 20°C.
- The units are washed with new plugs/cables.
- The cables should be as long as possible and free ends should be shut off.
- Detergent and rinsing aids used:
  - Detergent 1: DR. WEIGERT neodisher Dekonta AF
  - Rinsing aid 1: DR. WEIGERT neodisher TN

**Test procedure:**

- The units are placed in the washing machine in the intended mounting direction (in the most sensible direction regarding water penetration, if this is not the same direction).
- The washing process (see picture below) is repeated 11 times and consists of:
  - Washing with 0.3 % alkaline detergent for 2 minutes in 70 °C hot water. (Note: the temperature is measured in the tank, not necessarily at the unit).
  - Rinsing with neutral rinsing aid for 20 seconds.
  - Drying and cooling for 30 minutes in the open air at approx. 20 °C.
- After 11 cycles, the products are left in a ventilated room for 24 hours. The above steps are repeated until a total of 250 cycles has been reached.
- Immediately after washing and after further 24 hours, the products are subjected to a high voltage test in accordance with UM-31-30-072.
- A population sample of the products is opened for water penetration control immediately after the washing test. Accept criteria are in accordance with UM-20-30-002.

**Options:** The following options can be used for the test:

- The units may be weighed prior to and after the washing test to detect water.
- The bubble test may be used to detect any leakages.
- X-ray may be used to detect any leakages.



## LINAK washing profile for the "IPX6 Washable DURA" process

### LINAK washing profile according to DURA™

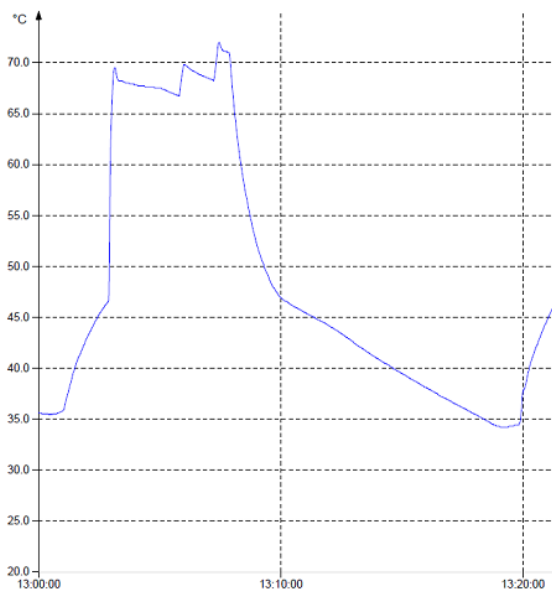

(Note: The temperature is measured at the unit)

### LINAK washing machine



## Cable wash

### Before the washing procedure starts

In order to maintain the flexibility of the cables, it is important that the cable is placed in such a way that the cable's own weight does not strain the coil during the washing process. This can be done by placing the cable ON the bed or another form of support for the cable. Please see the examples in the picture to the right.

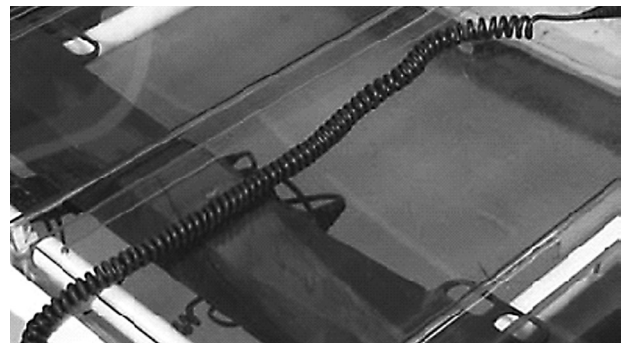

## General maintenance

If not otherwise stated in the specific product section.

- LINAK products must be cleaned at regular intervals
- Frequent inspection for malfunction, mechanical damage, wear and cracks. Worn-out parts must be replaced
- Inspection/maintenance intervals are to be recommended by the medical device manufacturer
- LINAK products are closed units and require no internal maintenance
- LINAK products must be IPX6 Washable and IPX6 Washable DURA when cleaning in wash tunnels
- O-rings: When individual parts are replaced in a LINAK IPX6, IPX6 Washable or IPX6 Washable DURA system, the O-rings must be replaced at the same time on all parts. On all products where replaceable cables or fuses have been dismantled or replaced, the O-ring must be replaced, and the O-rings and the receptacle insert must be greased with an acid-free Vaseline.



## Maintenance of all LINAk actuators

- Actuators/lifting columns must be regularly inspected at attachment points, wires, piston rod, enclosure, and plugs, and it must be checked that the actuators/lifting columns function correctly
- To ensure that the pregreased inner tube remain lubricated, the actuator must only be washed when the piston rod is fully retracted

## Maintenance of all LINAk lifting columns

- Actuators/lifting columns must be regularly inspected at attachment points, wires, piston rod, enclosure, and plugs, and it must be checked that the actuators/lifting columns function correctly
- To ensure that the pregreased inner tube remain lubricated, the actuator must only be washed when the piston rod is fully retracted

## Maintenance of all LINAk control boxes

- Electronics must be inspected at attachment points, wires, enclosure, and plugs
- Inspect the connections, cables, enclosure, and plugs, and check for correct functioning
- LINAk electronics are maintenance-free (however, this does not apply to lead acid batteries)

## Maintenance of all LINAk controls

- Electronics must be inspected at attachment points, wires, enclosure, and plugs
- Inspect the connections, cables, enclosure, and plugs, and check for correct functioning
- LINAk electronics are maintenance-free (however, this does not apply to lead acid batteries)

## Maintenance of all LINAk accessories

- Electronics must be inspected at attachment points, wires, enclosure, and plugs
- Inspect the connections, cables, enclosure, and plugs, and check for correct functioning
- LINAk electronics are maintenance-free (however, this does not apply to lead acid batteries)



## Repair and disposal

Only an authorised LINAK® service centre should repair the LINAK actuator systems. Systems to be repaired under warranty must be sent to an authorised LINAK service centre.

In order to avoid the risk of malfunction, all actuator repairs must only be carried out by an authorised LINAK Service shop or repairers, as special tools and parts must be used.

If a system is opened by unauthorised personnel there is a risk that it may malfunction at a later date.

LINAK systems or components may be disposed of, possibly by dividing them into different waste groups for recycling or combustion.

We recommend that our product is disassembled as much as possible at the disposal and that you try to recycle it. LINAK systems or components should be disposed of in accordance with the environmental regulations applicable in the respective country.



## Insulation class

LINAK® control boxes are available in insulation Class I and insulation Class II.

## Output ratings

Nominal values:

On LINAK® control boxes, battery boxes and power supply marking plates, the nominal output voltage at a certain load for a certain product may be stated.

Depending on product and load, this value may vary significantly due to construction.

The expected output voltage may for instance vary depending on product and load within a range from approximately 20 V DC to approximately 50 V DC for a product with a nominal output voltage of 24 V DC due to the construction.

When combining LINAK control boxes, battery boxes and power supplies with other LINAK components, compatibility is ensured. When combining LINAK control boxes, battery boxes or power supplies with third party products, special precautions may be taken. In this case, contact LINAK.



## Troubleshooting

Symptom	Possible cause	Action
No motor sound or movement of piston rod	<ul style="list-style-type: none"> <li>- The actuator is not connected to the control box</li> <li>- Blown fuse in the control box</li> <li>- Cable damaged</li> </ul>	<ul style="list-style-type: none"> <li>- Connect the actuator to the control box</li> <li>- Fuse must be changed</li> <li>- Send actuator for repair</li> </ul>
Excessive electricity consumption		<ul style="list-style-type: none"> <li>- Send actuator for repair</li> </ul>
Motor runs but spindle does not move	<ul style="list-style-type: none"> <li>- Gear wheel or spindle damaged</li> </ul>	<ul style="list-style-type: none"> <li>- Send actuator for repair</li> </ul>
Actuator cannot lift full load	<ul style="list-style-type: none"> <li>- Clutch is worn</li> <li>- Motor is damaged</li> </ul>	<ul style="list-style-type: none"> <li>- Send actuator for repair</li> </ul>
Motor sound but no movement of piston rod		<ul style="list-style-type: none"> <li>- Send actuator for repair</li> </ul>
No signal from Reed or Hall switch		<ul style="list-style-type: none"> <li>- Send actuator for repair</li> </ul>
Motor runs and quick release does not function or is noisy	<ul style="list-style-type: none"> <li>- Declutching arm turns less than approx. 75 °C</li> </ul>	<ul style="list-style-type: none"> <li>- Adjust cable</li> </ul>
Piston rod will only move inwards and not outwards	<ul style="list-style-type: none"> <li>- Safety nut has operated</li> </ul>	<ul style="list-style-type: none"> <li>- Send actuator for repair</li> </ul>
	<ul style="list-style-type: none"> <li>- Not connected to mains</li> </ul>	<ul style="list-style-type: none"> <li>- Connect to mains</li> </ul>
Power indicator does not light up	<ul style="list-style-type: none"> <li>- The fuse has blown</li> </ul>	<ul style="list-style-type: none"> <li>- Replace fuse, if the system is prepared for external fuse replacement, or send the system for repair</li> </ul>
	<ul style="list-style-type: none"> <li>- Defective power cable</li> </ul>	<ul style="list-style-type: none"> <li>- On control boxes with exchangeable power cable, change the cable.</li> <li>- On control boxes with fixed cable, send it for repair</li> </ul>
	<ul style="list-style-type: none"> <li>- Control box defective</li> </ul>	<ul style="list-style-type: none"> <li>- Send control box for repair</li> </ul>
	<ul style="list-style-type: none"> <li>- Actuator plug not pushed into control box properly</li> </ul>	<ul style="list-style-type: none"> <li>- Push actuator plug properly into control box</li> </ul>
Power indicator lights up, but actuator does not run	<ul style="list-style-type: none"> <li>- Actuator defective</li> </ul>	<ul style="list-style-type: none"> <li>- Replace actuator</li> <li>- Defective control box</li> <li>- Replace the control box</li> </ul>
Control box relays are clicking	<ul style="list-style-type: none"> <li>- Control box defective</li> </ul>	<ul style="list-style-type: none"> <li>- Send control box for repair</li> </ul>
Power indicator lights up, but actuator does not run	<ul style="list-style-type: none"> <li>- Hand control defective</li> </ul>	<ul style="list-style-type: none"> <li>- Send hand control for repair</li> </ul>
No relay noise is heard from control box Not valid for CB20/CB6S OBF/CB16 OBF	<ul style="list-style-type: none"> <li>- Battery completely flat</li> </ul>	<ul style="list-style-type: none"> <li>- Charge battery</li> </ul>
Control box completely dead on battery and no relay clicking	<ul style="list-style-type: none"> <li>- Battery defective</li> </ul>	<ul style="list-style-type: none"> <li>- Replace battery</li> </ul>
	<ul style="list-style-type: none"> <li>- Actuator plug not properly pushed into control box</li> </ul>	<ul style="list-style-type: none"> <li>- Push actuator plug properly into control box</li> </ul>
Actuator does not run on battery, but relay clicking can be heard	<ul style="list-style-type: none"> <li>- Actuator defective</li> </ul>	<ul style="list-style-type: none"> <li>- Replace actuator</li> </ul>
	<ul style="list-style-type: none"> <li>- Control box defective</li> </ul>	<ul style="list-style-type: none"> <li>- Replace control box</li> </ul>
	<ul style="list-style-type: none"> <li>- Hand control defective</li> </ul>	<ul style="list-style-type: none"> <li>- Send hand control for repair</li> </ul>
	<ul style="list-style-type: none"> <li>- Control box defective</li> </ul>	<ul style="list-style-type: none"> <li>- Send control box for repair</li> </ul>
Control box okay apart from one direction on one channel		



## LA22



The LA22 is an in-line actuator specially designed with a small overall dimension for easy use in industrial, agricultural, and rehabilitation products.

Thanks to its small outer dimensions and linear design, the LA22 is well suited for applications where installation space is limited, such as on wheelchairs.

## LA32



The LA32 actuator is a powerful actuator that can be supplied with a ball screw spindle to give outstanding performance. The ideal choice for a wide range of applications including adjustment of hospital beds.

The LA32 actuator has many special options including a safety nut, splines, quick release (F) and an optional protection up to IPX6 standard.

Reed-switch:

The Reed-switch gives a number of pulses for each rotation of the motor. These pulses are used to calculate the piston rod's position as well as to control several actuators running in parallel.

Your nearest LINAk dealer can inform the number of pulses per stroke length.

### Usage

Duty cycle:	Max. 10% or 2 minutes continuous use followed by 18 min. not in use
Storage temperature:	-10 °C to +50 °C
Compatibility:	Compatible with LINAk control boxes. Please contact LINAk.
Approvals:	IEC60601-1 ANSI/AAMI ES60601-1 CAN/CSA-22.2 No 60601-1



### Recommendations

- The piston rod eyes are "crimped" in place and cannot be screwed loose.

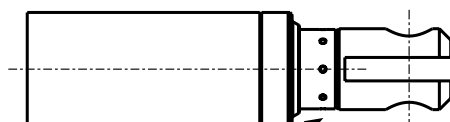

"Crimped" piston rod eye

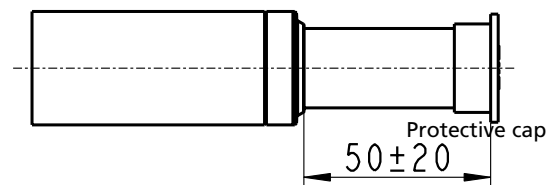

Piston rod without eye

- Piston rods without eyes are not tested
- LA32 with quick release and free wheeling function must not be sold to new products
- Maximum load in pull = 2000 N



LA32 actuators for patient hoists are marked with a label to ensure the user is aware that it is not permitted to handle the patient hoist by pulling the actuator or otherwise expose it to side forces.

### LA32 Actuator with potentiometer

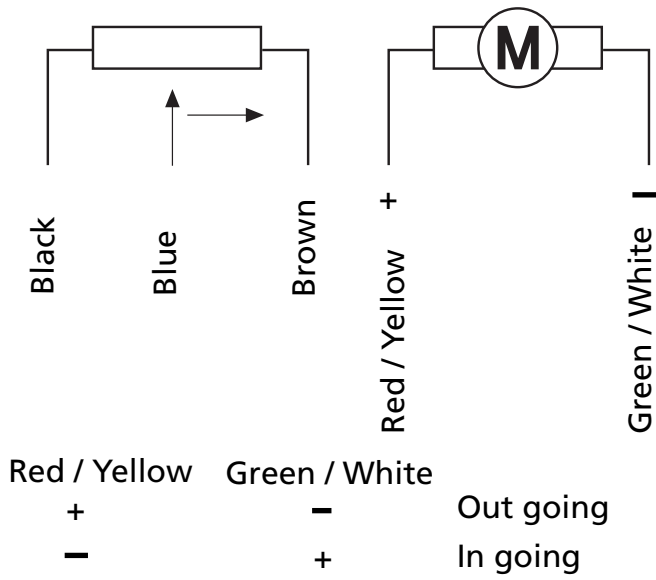

### LA32 Actuator with reed ( only possible with 24V L-motor )

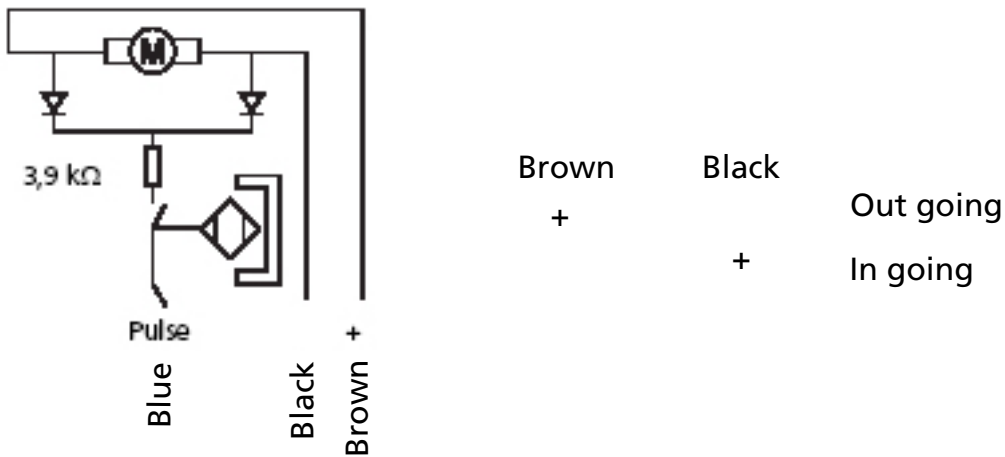

## LA43



The LA43 is available in a powerful 8,000N version, ensuring safe patient handling.

With the LA43 actuator, LINAK offers a product, which with its wide range of safety options, low noise level, and outstanding performance is the right choice for medical applications such as patient lifts, beds, dental chairs etc.

### Usage

Duty cycle:	10%, 2 minutes continuous use followed by 18 minutes not in use
Usage temperature:	5°C to 40°C
Storage temperature:	- 10°C to +50°C
Compatibility:	CBJ1/2, CBJ-Home, CBJ-Care, CB6S, CB16, CB20
Approvals:	IEC60601-1



### Recommendations

- The actuator is not suitable for outdoor applications
- Power supply without current cut-off can cause serious damage to the actuator if a mechanical stop is encountered or the actuator movement is blocked in another way.
- If there is a risk of “pull forces” in the application, the actuator must be equipped with electrical spline to avoid damage in pull.
- If the actuator is operated without load (e.g. loose on a table) the electrical spline can activate and the actuator cannot run in an inwards direction. Push the back fixture and the actuator can be operated again.
- Connection bolts must be dimensioned so that they have the necessary strength in order to obtain the minimum safety factor according to the requirements of the authorities.
- The actuator must not be subject to a side load, as this can cause bending. It is also for this reason that the actuator should not be used as a handle, e.g pulling a patient hoist sideways.
- The actuator must not be subject to off centre loading, as this can damage the actuator.
- The actuator must not be subject to impact, or any form of stress to the casing.
- The actuator must not be subject to overload, as this can reduce the lifetime of the actuator and in the worst case cause damage to the actuator.
- The actuator must not be used in pull applications, as this can cause collapse.
- Only use the actuator within the specified working limits.
- It is recommended that the actuator is serviced according to the relevant national norms for the applications in which the actuator is used.
- Connection bolts and brackets are to be inspected in connection with service, and must be replaced if there are signs of wear.
- The safety function: Electrical Spline, should be checked in connection with service.
- The function is checked by applying a straight pull, of max. 100 N. The actuator must not be able to run in an inward direction.



- Hereafter press the back fixture against the housing and the actuator can run in an inward direction.
- The actuator should be cleaned regularly, in order to maintain a good hygiene.
- The application must be tested for correct functionality before putting it back into operation.
- Do not step or kick on the actuator as it may damage the housing or the motor.

### Patient Lifts and Stand Aids

- Long installation dimension: Must always be used for patient lifts.
- Do not hold the inner or outer tube while the actuator is running. There can be a risk of squeezing between the Manual Lowering unit and the outer tube.
- Do always use the electrical spline function for patient lifts



LA43 actuators for patient hoists are marked with a label to ensure the user is aware that it is not permitted to handle the patient hoist by pulling the actuator or otherwise expose it to side forces.



### Warnings

- It is not allowed to use tools to adjust the installation dimension of the LA43 actuator as there is a risk that the inner tube may be unscrewed.

### Self-locking ability

LINAK control boxes are designed so that they will short-circuit the motor terminals (poles) of the actuator(s), when the actuator(s) are not running. This solution gives the actuator(s) a higher self-locking ability. If the actuator(s) are not connected to a LINAK control box, the terminals of the motor must be short-circuited to achieve the self-locking ability of the actuator.



### MANUAL LOWERING

The following pictures illustrate the manual lowering procedure.

In case of a power failure it is possible to mechanically lower a patient placed in a patient hoist.

When turning the manual lowering handle clockwise the actuator can be moved fully inwards.

### FITTING THE PLUG/SMART CABLE LOCK:

The following pictures illustrate how to fit the plug connection using the "smart cable lock manual lowering procedure.



#### Step 1:

Insert the cable in the socket.  
Make sure the O-ring on the cable is fully inserted.



#### Step 2:

Attach the cable lock.  
Make sure the inclined surface is facing upwards.



#### Step 3:

Push the cable lock inside the slot.  
If necessary, the cable can be pushed down at the same time to ease the cable lock mounting.



## LA43 IC



The LA43 is available in a powerful 8,000N version, ensuring safe patient handling.

With the LA43 actuator, LINAK offers a product, which with its wide range of safety options, low noise level, and outstanding performance is the right choice for medical applications such as patient lifts, beds, dental chairs etc.

### Usage

Duty cycle:	10%, 2 minutes continuous use followed by 18 minutes not in use
Usage temperature:	+ 5° C to + 40° C
Storage temperature:	-10° C to + 50° C
Compatibility:	SMPS30
Approvals:	IEC60601-1



### Recommendations

- The actuator is not suitable for outdoor applications
- If there is a risk of “pull forces” in the application, the actuator must be equipped with electrical spline to avoid damage in pull.
- If the actuator is operated without load (e.g. loose on a table) the electrical spline can activate and the actuator cannot run in an inwards direction. Push the piston rod and the actuator can be operated again.
- Connection bolts must be dimensioned so that they have the necessary strength in order to obtain the minimum safety factor according to the requirements of the authorities.
- The actuator must not be subject to a side load, as this can cause bending. It is also for this reason that the actuator should not be used as a handle, e.g pulling a patient hoist sideways.
- The actuator must not be subject to off centre loading, as this can damage the actuator.
- The actuator must not be subject to impact, or any form of stress to the casing.
- The actuator must not be subject to overload, as this can reduce the lifetime of the actuator and in the worst case cause damage to the actuator.
- The actuator must not be used in pull applications, as this can cause collapse.
- Only use the actuator within the specified working limits.
- It is recommended that the actuator is serviced according to the relevant national norms for the applications in which the actuator is used.
- Connection bolts and brackets are to be inspected in connection with service, and must be replaced if there are signs of wear.
- The safety function: Electrical Spline, should be checked in connection with service.
- The function is checked by applying a straight pull of max. 100 N to the piston rod. The actuator must not be able to run in an inward direction.
- Hereafter press the piston rod and the actuator can run in an inward direction.
- The actuator should be cleaned regularly, in order to maintain a good hygiene.
- The application must be tested for correct functionality before putting it back into operation.
- Do not step or kick on the actuator as it may damage the housing or the motor.



## Safety concept

The user is a part of the safety concept. A light on the SMPS30 is green when a button on the handset is not activated. When a switch is activated the light changes to orange. Orange indicates that power request is on.

When the light is orange and a button is not activated there is a fault on the system. And the user must call for service.

## Cable connections

SMPS connection, 4-pole minifit plug

Handset/FS connection, 10-pole modular jack/ 6-wire standard cable.

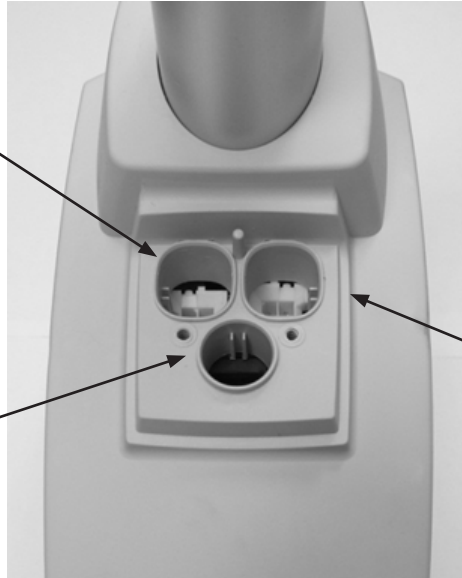

Second actuator connection, 6-pole minifit plug or blind plug

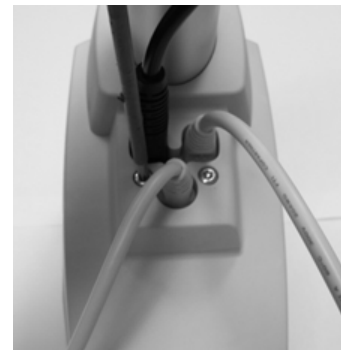
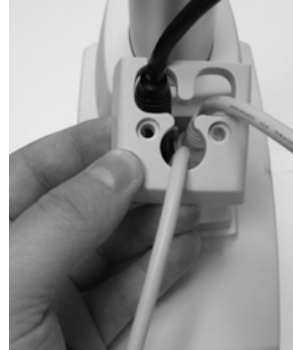

### Step 1:

Insert the cables in the sockets.  
Make sure the O-rings on the cables are fully inserted.

### Step 2:

Insert the cables into the cable lock.  
Make sure that the correct cables are placed in the corresponding holes.

### Step 3:

Attach the cable lock and secure it with screws.  
The tightening torque should be 0.4 Nm.

## Cable connection and cable lock:

Tighten the two screws with approx. 0.4 Nm torque to secure the cable lock.  
Cable lock and screws to be ordered separately.

## LA44 IC



The LA43 Intelligent Control (IC) enables a simple system consisting of 1 or 2 actuators, a Switch Mode Power Supply and a hand control or a footswitch.

The system is for example an advantage when there is no space for a control box.

### Usage

Duty cycle:	10%, 2 minutes continuous use followed by 18 minutes not in use
Usage temperature:	+ 5° C to + 40° C
Storage temperature:	-10 °C to +50 °C
Compatibility:	SMPS30
Approvals:	IEC60601-1 ANSI/AAMI ES60601-1

### Cable connections

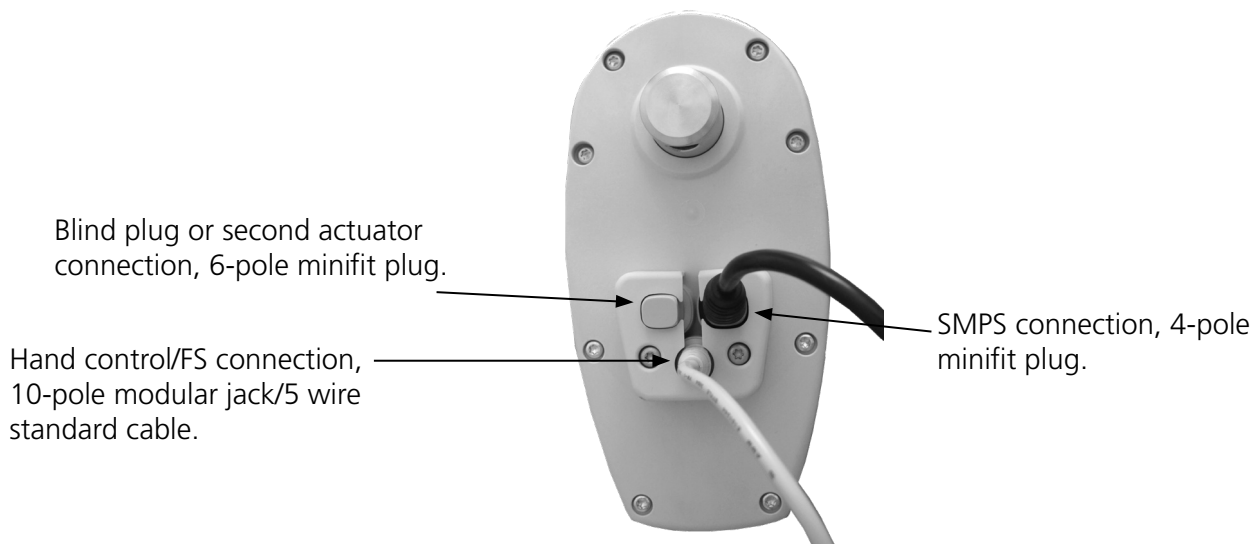

### Cable connection and cable lock

Tighten the two screws with approx. 1.5 Nm torque, to secure the cable lock.

## BB3



The BB3 3-part telescopic actuator is the ideal choice for vertical lift of beds where design and easy integration in the customer's guidance ensures optimum freedom of design.

The BB3 is a 3-part telescopic actuator designed to meet EN 1970 for care beds, which demands an adjustment range from 350 mm up to 750 mm.

### Reed-switch

The Reed-switch gives a number of pulses for each rotation of the motor. These pulses are used to calculate the piston rod's position as well as to control several actuators running in parallel.

Your nearest LINAK dealer can inform you of the number of pulses per stroke length.

- The columns must be securely mounted before operation, no rotation must be possible
- The motor housing must be mounted uppermost.



### Warnings

- Do only use the column within specified working limits.



## BL4



The BL4 is a 4-part lifting column specially designed for hospital and care beds; the BL4 can of course be used for other applications where a compact lifting column with a long stroke length is needed.

The lifting column is based on the BB3 actuator, which is practically noiseless. The specifications comply with the demands to the lifting functions in beds as to load, speed and stroke length.

### Reed-switch

The Reed-switch gives a number of pulses for each rotation of the motor. These pulses are used to calculate the piston rod's position as well as to control several actuators running in parallel.

Your nearest LINAK dealer can inform you of the number of pulses per stroke length.

### Usage

Duty cycle:	Up to 10% or max. 2/18 min.
Operation temperature:	+5 °C to +40 °C
Compatibility:	CB9AF, AL, AM, CB12H (special version), CB14 and OpenBus™ control boxes e.g. CB20

### Technical specification

Load in push:	Max. 1500 N See label
Load in pull (dynamic):	0N
Load in pull (static):	Max. 600 N
Bending moment (static):	Max. 500 Nm
Bending moment (dynamic):	Max. 250 Nm
Duty cycle:	10 % Max. 2 min./18 min. See label
Protection classes:	IPX4, IPX6 and IPX6 Washable
Usage temperature:	+5 °C to +40 °C
Storage temperature:	Max. 50 °C

Your nearest LINAK dealer can inform the number of pulses per stroke length.

- There are mounting holes in the endplates and motor housing
- The columns must be securely mounted before operation, no rotation must be possible
- The motor housing must be mounted uppermost
- The mounting bracket tension must be adjusted correctly



## Warnings

- Do only use the column within specified working limits.
- The BL4 is heavy (8.2 kg) To avoid personal injury, DO NOT DROP!
- Do not adjust anything during movement, can cause personal injury!
- The BL4 is designed for use in push applications, dynamic “Pull forces” can result in damage to the column and cause collapse of the application.
- Do not loosen any screws on the BL4, this can cause collapse of the column!
- IPX6 washable versions must not be dismantled and then rebuilt again without the motor housing being changed in order to ensure the washability.
- There must be at least 4 hours between each washing cycle to allow the BL4 to resume normal temperature.



## Recommendations

- Max. storage temperatures: +50 °C.
- BL4 is for use in push applications only and only mounted with the motor housing uppermost.
- Actuators using “buffer” end-stop principle are not compatible with BL4 and CB9 systems.
- If the column is driven in end-position (end-stop switches in the actuator will be activated ) and if the hand control is kept activated you will in
- some cases, depending on the column load, see that the actuator starts and stops as long as the hand control is activated.

### Recommendations with washable versions

- IPX6 Washable versions must not be dismantled and then be rebuilt again without the motor housing being changed in order to ensure the washability.
- There must be at least 4 hours between each washing cycle to allow the BL4 to resume normal temperature.



## BL4 Mounting guidelines



### Recommendations

- The BL4 must always be mounted vertically before operation and always vertical with the motor housing uppermost.
- (Otherwise, the internal end-stop switch system can break due to rotation).
- Both the motor housing and the bottom tube (the one with the largest diameter) must be secured in the application in such a way that no rotation can occur.
- It is recommended to monitor the current consumption in order to determine the necessary tensioning force for the mounting bracket.
- If the current consumption rises the BL4 has been tightened too much.

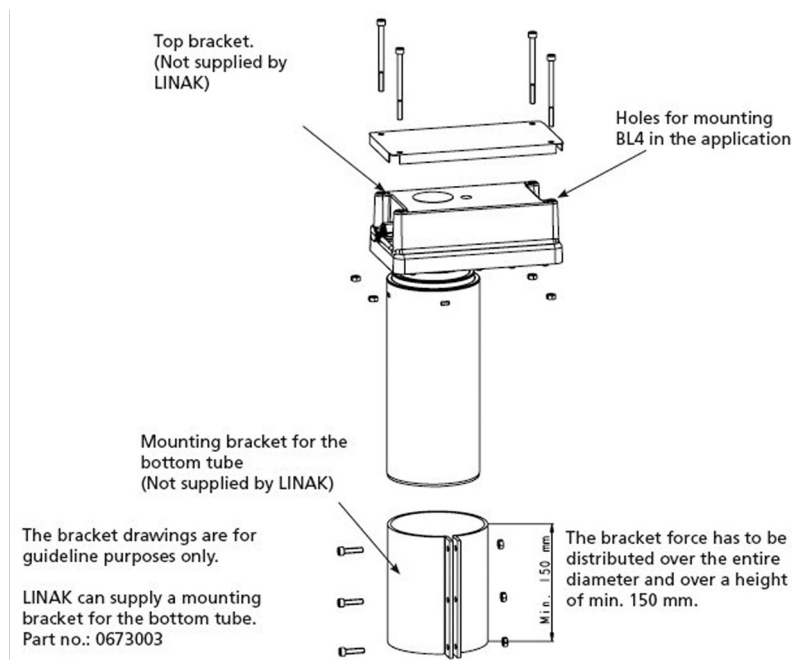

### Recommendations

- The mounting plate in the application must cover the entire top plate of the BL1 and be strong enough to carry the load.
- It is recommended that all 4 holes in the motor housing are used to fasten the BL4 to the application.
- The screws must provide a secure fixing e.g. as with self-locking.
- Remember to secure the cable to the housing with a cable tie. Use the fixing eye next to the connector socket.
- On the BL4 cables, clip sleeve are mounted, they need to be removed.
- Electro Static Discharges!
- Be aware that there is no electrical connection through the length of the BL4 column. Therefore, to avoid ESD issues, consider external potential alignment between the top and bottom of the bed frame.



**When mounting more than one BL4 you need to consider the fixation:**

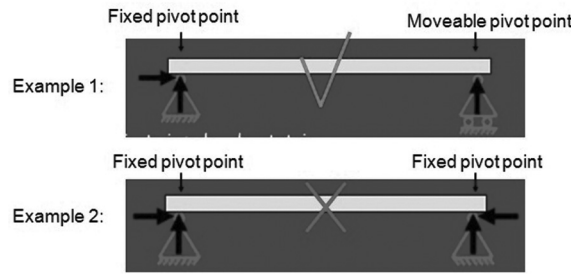

The reason why it is important only to fix one column is that the columns will not move exactly in parallel – even if you have positioning such as hall. If more than one column is fixed, it can lead to dangerous situations.

If you have trend/antitrend function in your application you need to mount one or more of the BL4s with a slider. Having sliders prevents the column from bending like illustrated below.

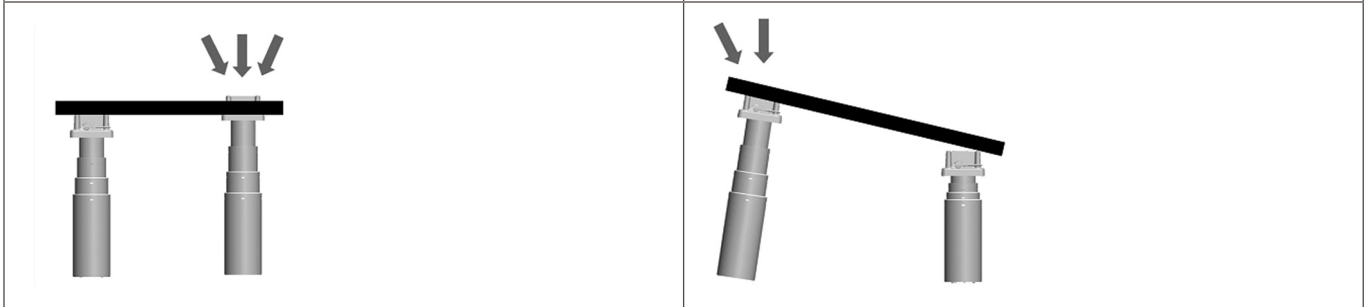

LINAK mounting bracket part no.: 0673003-A

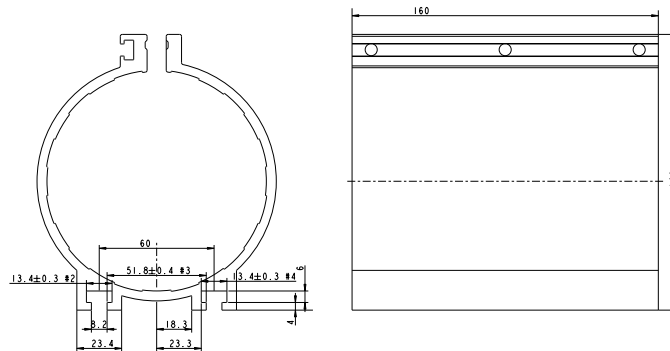

**Mounting guidelines for the BL4 bracket, supplied by LINAK, part no. 0673003:**

Mounting the bracket in the application:

- The bracket must be mounted to an even abutting plate in the application by using the 2 slits.
- In each slit at least 3 bolts must be mounted. Type M8 8.8.
- Tightening moment must be 22.7 - 26.1 Nm.
- The 3 bolts must be placed in the same height as the 3 holes.

Mounting of the BL4 into the bracket:

- The BL4 must be fitted in the bracket after mounting the bracket to the application.
- 3 bolts and nuts must be mounted in the 3 holes. Type M6 8.8
- Tightening moment must be  $10.3 \pm 0.3$  Nm

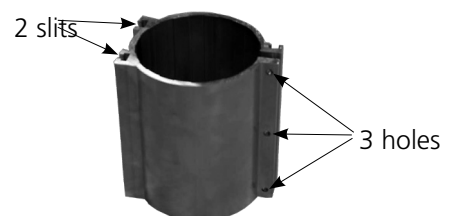

The mounting points must be re-tightened at least once a year with the above specified moments.



## LC2



The LC2 column is an update of the LP2 program. It has an improved “twisting” stability and end stop switches as standard.

The column is designed to be used in a vertical position and only for lifting purposes. It is not possible to use the column in any kind of “pull” application.

Depending on the application, the LC2 can be operated either as a single column or several columns in a parallel system by choosing a control box with micro-processor.

It is designed to provide vertical lifting (push only) where simultaneous bending and torsion moments exist.



### Warnings

- Do only use the column within specified working limits.



## LP2



The LP2 range of vertical lifting columns is ideal where vertical positioning of substantial loads is required.

### Usage

Ambient temperature:	+5 °C to +40 °C
Duty cycle:	2/18, 2 minutes continuous use followed by 18 minutes not in use
Compatibility:	LP2 is compatible with CB8, CB12 or CB14
Approvals:	IEC60601-1 ANSI/AAMI ES60601-1 CAN/CSA-22.2 No 60601-1



### Recommendations

- Cleaners and disinfectants must not be highly alkaline or acidic (pH value 6-8)
- Depending on the choice of control box, it is possible to operate 2 lifting columns in parallel and save up to 3 memory positions.
- If parallel drive or memory function is required, the lifting column has to be ordered with reed switch.
- If LP2.2 is used as a single column, twisting of the column is a possible effect that can occur during the lifetime of the column.
- The column is not constructed to withstand twisting in an application.
- The column must only be mounted with the largest profile uppermost.



### Warnings

- The column can only be loaded with the maximum bending moment over the first 80% of the stroke.
- Above this 80% figure, the max. bending moment will be reduced to 50%.
- The column must not be used in pull.



## LP3



LP3 is developed for vertical lifts and can resist a bending moment by virtue of the effective telescopic system.

The lifting column is designed for applications where a small installation dimension is requested without compromising the lifting capacity.

The LP3 is characterised by having a lower installation dimension proportional to the stroke length compared with LP2. LP3 can also attain a higher speed than LP2.

The telescopic column is compatible with LINAK's control boxes and can run individually; as 2 x LP3 parallel and/or with memory.

The LP3 is the perfect choice for height adjustment on dental, gynaecologist, and wheelchairs as well as for operating, office and working benches etc.



### Recommendations

- The column can only be loaded with the maximum bending moment over the first 80% of the stroke. The maximum bending moment will be reduced to 50%.
- The column must be mounted with the largest profile uppermost!

There are mounting holes in the end plates.

The largest profile must be mounted uppermost.



### Warnings

- Do only use the column within specified working limits.
- Ensure a safe connection between column and application
- Side mounting bracket screws: use the correct torque on the side mounting bracket screws.
- The column can not be used in pull
- Max. bending:      LP3 = 375 Nm

## CA10



The CA10 is a cost-efficient analogue control box developed primarily for the long-term care sector with a specific focus on homecare bed applications. With its compact and streamlined design, it is easy to install and simple to use.

### Usage

Operation temperature:	+5 °C to +40 °C
Storage temperature:	-10 °C to +50 °C
Relative humidity:	20% to 80% – non-condensing
Atmospheric pressure:	700 to 1060 hPa
Meters above sea level:	Max. 3000 meters
Approvals:	IEC-60601-1 ANSI/AAMI ES60601-1 CSA CAN/CSA-C22.2 NO. 60601-1



### Important system approval information

The CA10 platform, powered via an external power supply (SMPS10), is certified in accordance with the general standard for medical electrical equipment, IEC 60601-1. The same applies to the SMPS10 power unit.

The CA10 is designed for IPX4 according to the requirements of the standard for medical beds, IEC 60601-2-52, and the SMPS10 is designed for IP21 according to the requirements of the standard IEC 60601-1-11 for medical electrical systems used in the home healthcare environment.

The IEC 60601-1 states that the requirements of an ME system distinguish between 'within' and 'outside' the PATIENT ENVIRONMENT.

When in active use, the SMPS10 is outside the PATIENT ENVIRONMENT and if/when cleaned, there is no longer a connection between the bed and the SMPS10.



## Mounting instructions

When mounting the control box (1) onto the actuator (2), connect the slide-on bracket to the rail. Slide until you hear a click and the box is mounted (3).

①

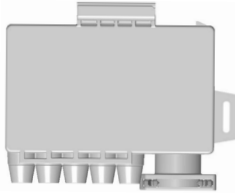

②

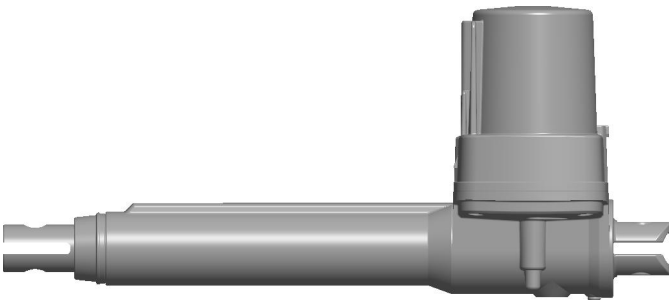

③

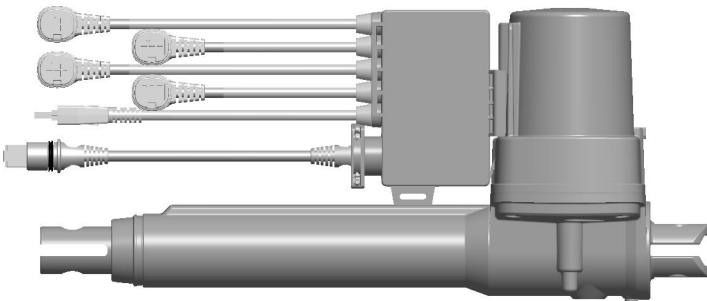

Please see the instructional video on how to mount and dismount the CA10 from the LA24 actuator on [LINAK.com](http://LINAK.com).



### Recommendations

- The hand control cable must be connected to the CA10 to ensure IPX4 protection.
- We recommend using the plastic ear for plastic strips around the outer tube in case it is necessary to dismount and remount CA10.
- For extra fastening, use plastic strips.



## Cables

Motor and power cables are fixed on the CA10.

Channel 1: 200 mm (O-ring colour = black)

Channel 2: 1300 mm (O-ring colour = red)

Channel 3: 950 mm (O-ring colour = orange)

Channel 4: 1800 mm (O-ring colour = yellow) (not for 3 channel version)

Power supply: 3200 mm

Cable lock is preinstalled item no. 0835126 (RAL 2003).



### Cleaning instructions

- When the cleaning method of the application exceeds IP21, disconnect the power supply from the application.
- Ensure that the connector is kept dry during cleaning.



### Recommendations

- Push plugs fully into correct sockets and make sure the plugs are completely inserted before mounting the cable lock.
- Take special precautions concerning third-party interfacing.
- We recommend one time mounting of CA10 only with the LA24.
- The CA10 can only be used with SMPS10.



### Warnings

- Pressing multiple keys simultaneously might cause an unintended trend or anti-trend movement.
- Be aware that the CA10 common current is limited by the SMPS.

## CB6 OBMe



The CB6OBMe is part of the LINAK OpenBus™ product range - that provides more flexible solutions no matter which actuator concept is preferred.

Is a powerful control box with Switch Mode Power Supply or traditional transformer solution which is typically used for applications like hospital beds, couches/tables for treatment and examination and other medical applications. The universal Switch Mode Power Supply makes the control box adaptable to the worldwide market irrespective of the input voltage.

### Features and options

Power supply: SMPS Universal: 270W, 100-240VAC 50/60Hz  
 Transformer toroidal: 270W, 230VAC 50/60Hz, 120VAC 60Hz

### Usage

Duty cycle: 10%, 2 min./18 min.  
 Approvals: IEC60601-1  
 ANSI/AAMI ES60601-1  
 CAN/CSA-22.2 No 60601-1

### Low Power consumption

Low Power is CB6OBMe with a standby power equal to the standby power loss in the transformer, typically approx. 2.5W. Exclusive power consumption from accessories. To reduce the power consumption, the microcontroller will shut down all circuits in standby. If there is no activity for 2 minutes the CB6OBMe will shut down and thereby turn off the lights in all accessories. If any accessories or other devices activate Power Request, the CB6OBMe will wake up again. See the state and transitions diagram of the CB6OBMe.

### Mains Operation

Mains is connected and full operation is possible. If the CB6OBMe is charging the battery it will stay in this state. All indicators will turn off after 2 minutes, except the charging indicator.

### Mains Low Power

Mains is connected, but the CB6OBMe is shut down to save as much power as possible.

### Battery Operating

Mains is disconnected and the CB6OBMe operates on battery. Full operation is possible as long as the battery voltage is above approx. 22V.

### Battery Low Power

Mains is disconnected and the CB6OBMe is shut down to save as much battery power as possible. The diagram below shows the state and transitions of the CB6OBMe.

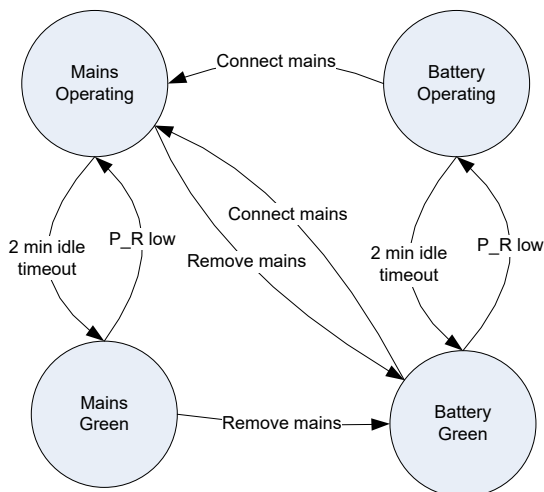

## Possible combinations

CB6OBMe – with transformer has been approved for CLASS I operation incl. CLASS I cables (with pigtail for earth).

CB6OBMe – with SMPS is not approved for CLASS I operation, basically because of the design of the housing.

However the PCB contains 2 x fuses (phase, neutral) as required for CLASS I operation.

## Duty Cycle Guard

CB6OBMe incl. SMPS comes as default with DCG (Duty Cycle Guard) to protect the system.

It is default set to 1020As, equal to approx. 2 min continuous use at 8A.

Example:

If 10 % duty cycle @ max. current is exceeded the CB shuts down. If instead an application is rated for 10 % duty cycle @ 50 % of max. current –

the duty cycle limit may be increased to 20 %.

If the CB shuts down it will recover for operation after 240 seconds (4 min.)!

## Battery Operation

### BATTERY LEVELS

BATTERY HIGH: > 20 V - normal

BATTERY MEDIUM: 17.5 - 20 V - alarm

BATTERY LOW: < 17.5 V - critical

- If the battery voltage is at 'medium level' a battery alarm beeps constantly when activating the HB/ACx. (Medium level means that battery charging is necessary to maintain the best possible lifetime. Medium level battery limit corresponds to approx. 17.5-20 V (+/- 5 %).
- If the battery voltage is at 'low level' (< 17.5 V), the battery alarm function shuts down all operation immediately.  
(If trying to operate the system anyway, the battery could become deeply drained or the actuator system could be damaged.  
When at critical battery level, there is a risk that the processor will incorrectly monitor end of stroke. Crashing the actuator could be a result.  
Critical level limit corresponds to approx. < 17.5 V (+/- 5%).
- If battery back-up is applied it only commences battery charging when it is connected to the mains.
- A battery stored at 25 °C has to be recharged every 6 - 7 months.
- Prior to first use of LINAK batteries, please make sure that they are charged for 24 hours in order to reach proper function and prolong the lifetime of the batteries.
- The longest lifetime is obtained when the battery is fully charged.

### If Backlight supported HB is used

- When CB6OBMe is powered by mains voltage:
  - If an HB button is activated the backlight illuminates fully.
  - When the HB button is released the light is dimmed again after approx. 10 - 15 sec.
  - Backlight turns completely off after 2 min.
  - Exception: While charging the HB backlight will stay on dimmed until charging is finished.
- When CB6OBMe is powered by battery:
  - If a HB button is activated the backlight illuminates fully.
  - When the HB button is released the light is dimmed again after approx. 10 - 15 sec.
  - Backlight turns completely off after 2 min.



## 1st Failure safe monitoring - transformer version

**Is made in two ways on the OBMe platform. It may be difficult to observe the LED status (hardware) if CB6 OBMe is placed under a bed, therefore it is now monitored by software as well.**

- CB6 OBMe is equipped with a 1st Failure safe indication controlled by HW (power request). At normal operation (no failure observed) the power LED turns yellow when a HB button is activated.

**If the LED has turned yellow AND the HB has NOT been activated, it indicates that a failure has occurred (1<sup>st</sup> Failure).**

### NOTE:

Even though the LED illuminates yellow before the HB is activated it is possible to operate the CB6, however the 1st.

Failure is somehow still in the CB and must be removed to prevent a further failure causing a hazardous failure to happen.

- To meet the safety requirements the device must have a dual switch safety concept. Further information about OpenBus™ safety concepts, please contact your local LINAK.
- The safety function must be monitored and this monitoring is implemented in the SW. In case of a failure (fatal error) any further operation of any channels are prevented. At a fatal error the CB6 OBMe responds with the following information:
- Failure indication:
  - all ACO LEDs are blinking
  - The CB6 OBMe buzzer beeps shortly if a handset is activated
  - The error can be reset by activating H0 and H1 OR H10 and H11 or H20 and H21 (standard SW only) on a handset.



## CB6P2



The CB6P2 platform is introduced to obtain a powerful and optimised solution to customers looking for existing analogue input systems. It is based on OpenBus™ technology, but to meet existing analogue systems it has an analogue input and therefore OpenBus accessories cannot be connected.

### Usage

Operation temperature:	+5 °C to +40 °C
Storage temperature:	-10 °C to +50 °C
Duty cycle:	10% - 2/18 min. on/off continuous use
Compatibility:	LA27, LA27 HALL, LA31, LA31 HALL, LA34, LA34 HALL, LA40 LA44, LA44 HALL, BL1, BL1 HALL
Relative humidity:	20% to 80% – non-condensing
Atmospheric pressure:	700 to 1060 hPa
Meters above sea level:	Max. 3000 meters
Approvals:	IEC60601-1 ANSI/AAMI ES60601-1 CAN/CSA-22.2 No 60601-1

### Combination Overview

CB6P2 is meant for use with:

- LA27 std. motor with Hall (cable type 'A')
- LA27 std. motor (cable type 'B')
- LA31 std. / fast motor with / without Hall
- LA34 std. / small / fast motor with / without Hall (fast motor not max. load)
- LA40 std. motor with / without Hall
- LA44 std. / fast motor with / without Hall (fast motor not max. load)
- BL1 (only with 270W transformer type) with / without Hall
- HB7x, HL7x, HB8x, ACL



## Recommendations

### Battery Operation

- If the battery voltage is at 'low level', a battery alarm beeps constantly when the HB/ACx is activated. (Low level means that battery charging is necessary to maintain the best possible life time. Low level battery limit corresponds to approx. 19 V (+/- 5%).
- If the battery voltage is at 'critical level' the battery alarm function shuts down all operation immediately.
- Critical level limit corresponds to approx. 17.5 V (+/- 5%).
- If battery back-up is applied it only commences battery charging when it is connected to the mains.
- A battery stored at 25° C has to be recharged every 6-7 months.
- Prior to first use of LINAK batteries, please make sure that they are charged for 24 hours in order to reach proper function and prolong the lifetime of the batteries.
- The longest lifetime is obtained when the battery is fully charged.



## CB6S



CB6S is part of the LINAK OpenBus™ product range - that provides more flexible solutions no matter which actuator concept is preferred.

### Mounting of CB6S – article no. 9271233

Apart from LA27 and LA40, it is not possible to mount CB6S onto LINAK actuators. In such case you need a CB6 mounting bracket which can be welded or likewise to the application. This bracket is shown below:

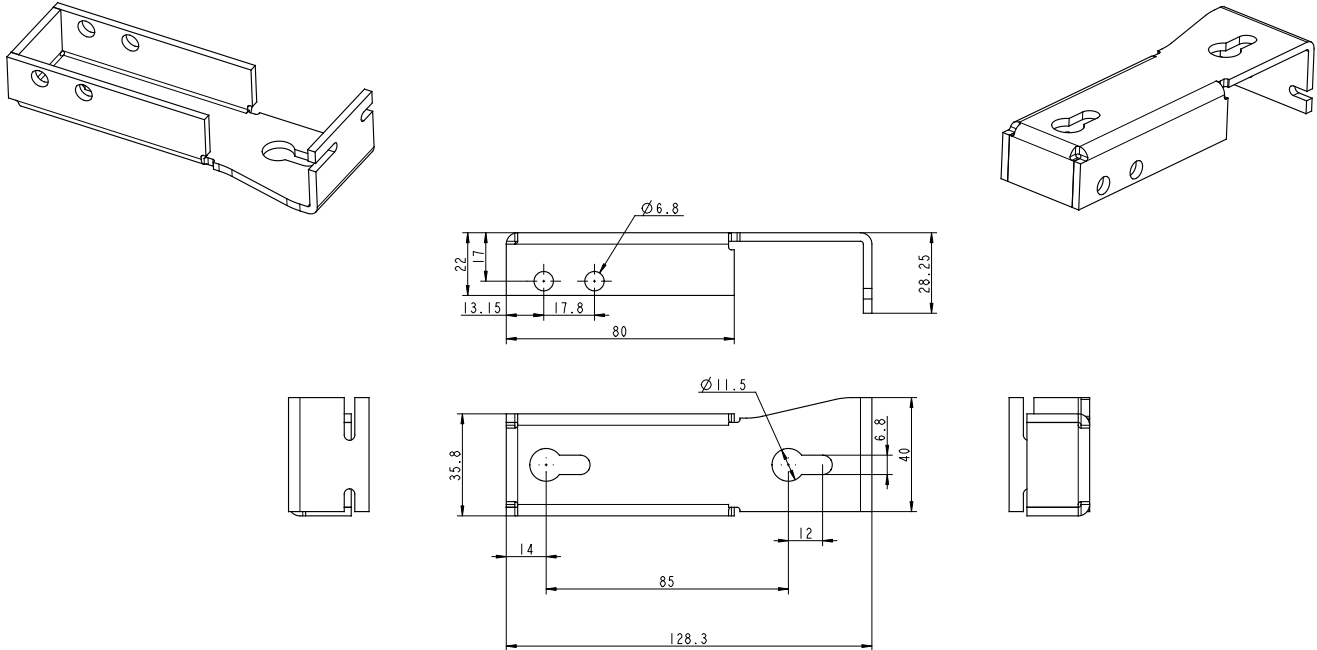

### Warnings

#### Thermal protection - OBF only

The CB is equipped with a thermal protection to avoid thermal overload of the FET transistors used to control the actuators.

When triggering the thermal protection all movement of the actuators will stop and the buzzer will sound for 5 seconds constantly. The 5 second alarm will be reinitiated each time the handset/ACP or similar is activated until the CB is cooled down enough to allow a movement again.

The thermal monitoring system monitors a temperature rise and not an absolute temperature. The monitoring system has been designed to operate up to an ambient temperature of 40 degrees. If the CB is exposed to a temperature higher than 40 degrees for several hours while powered it will adapt to this temperature. In this case there is a risk of damaging the FET transistors without triggering the thermal protection.

At first power up, after programming a new SW into the CB, the 'temperature reference value', used by the thermal monitoring system, will be automatically initialised. If this is done in a cold area the temperature reference value will be set accordingly and a too early temperature warning could occur (warning signal is temperature hoot = constant beep)!

After the first power up, the temperature reference value will adapt over time to the surrounding temperature and the adaptation routine happens every 5 hours (provided the CB is unused and connected to mains). The 5 hour counter (used by the temperature adaptation routine) will be reinitiated every time a handset/control panel is activated. We therefore recommend that the CB is resting for min. 5 hours to adapt temperature wise to a 'normal operating' temperature, i.e. in the environment for intended use.

**NOTE - HOT PLUGGING**

Removing or adding any OpenBus™ cables is not allowed when the CB is powered by mains supply!

If needed anyway, follow the below procedure:

1. Remove mains and wait 5 sec.
2. Mount or dismount the required cables

If this procedure is NOT followed, it may result in a damaged OpenBus driver circuit.

The risk of a damaged circuit increases if the accessory has a high start current (in rush current).

OBF - hot-plugging protected from January 2016.

**Battery operation****OBL and OBF:**

- If the battery voltage is at 'low level' a battery alarm beeps constantly (Low level means that battery charging is necessary to maintain the best possible lifetime. Low level battery limit corresponds to approx. 19 V (+/- 5%).
- If the battery voltage is at 'critical level' the battery alarm function shuts down all operation immediately. (If trying to operate the system anyway, the battery could become deeply drained or the actuator system could be damaged. When at critical battery level there is a risk that the processor will incorrectly monitor end of stroke. Crashing the actuator could be a result. Critical level limit corresponds to approx. 17,5 V (+/- 5%).
- The CB6S with battery back-up only commences battery charging when it is connected to the mains.
- A battery stored at 25° C has to be recharged every 6-7 months.
- Prior to first use of LINAK batteries, please make sure that they are charged 24 for hours in order to reach proper function and prolong the lifetime of the batteries.
- The longest lifetime is obtained when the battery is fully charged.

**IF BACKLIGHT SUPPORTED HB IS USED:**

- When CB6S is powered by mains voltage:

At no operation of the HB the backlight in the HB is dimmed.

If a HB button is activated the backlight illuminates fully.

When the HB button is released the light is dimmed again after approx. 10-15 sec.

- When CB6S is powered by battery:

At no operation of the HB there is no backlight in the HB.

If a HB button is activated the backlight illuminates fully.

When the HB button is released the backlight turns off.

**1ST FAILURE SAFE MONITORING:****OBF**

More information about 'OpenBus™ SW guidance', please contact your local LINAK department.

Mounting of LA27/LA40 on OBF is not recommended because of the big toroidal transformer used.



## CB12



The CB12 product range features two standard versions, which are ideal for a vast number of medical and industrial applications.

In general the CB12 is a transformer operated control unit, which can control up to 4 actuators. The control box features a range of built-in safety devices, increased current cut-off, EAS (Electronic Arc Suppression) and other options such as battery back-up, earth outlet, wet alarm etc.

### CB12 with battery backup

The CB12 with battery backup has an acoustic alarm, which sounds when the batteries are low, approx. 17 - 18V. To charge the batteries on a CB12 with internal batteries, just connect the CB12 to mains. With external batteries, connect the external batteries to an external charger.

### External battery charger

If anything other than a LINAK® charger is used, it must conform to the following specifications:

Charging voltage: 27.6 V DC  $\pm$  2%

Charging current: < 300 mA.



### Warning

- In order to avoid injury, a system with control(s) or accessories, a CB12 with battery backup and actuators assembled, must always be disassembled in transport and service situations.

## CB14



The CB14 with microprocessor is developed for systems with a need to run up to five actuators or two actuators / lifting columns in parallel and / or with memory function.

The effective toroidal transformer and the many features such as battery back-up, earth outlet, wet alarm makes the control box suitable for a variety of applications.

### CB14 with battery backup

The CB14 with battery backup has an acoustic alarm, which sounds when the batteries are low, approx. 17 - 18 V. To charge the batteries on a CB14 with internal batteries, just connect the CB14 to mains. With external batteries, connect the external batteries to an external charger.

### Memory position on CB14

When storing the memory position on CB14 the actuators must be run to the wanted position and the "store" button (S) must be pushed. Hereafter, the selected memory button (1, 2, or 3) must be activated within 2 seconds.

### Microprocessor

All control boxes with a microprocessor must be initialized before start-up. A description of the initialisation procedure can be obtained from your LINAK dealer. If an actuator is replaced, the microprocessor always has to be initialised before use (actuators with reed/hall).

If re-programmed, please ensure that the correct software is used.

### External battery charger

If anything other than a LINAK® charger is used, it must conform to the following specifications:

Charging voltage: 27.6 V DC  $\pm$  2%

Charging current: < 300 mA



### Warnings

In order to avoid injury, a system with control(s) or accessories, a CB14 with battery backup and actuators assembled, must always be disassembled in transport and service situations.

## CB16



CB16 is part of the LINAK® OpenBus™ product range. It is a powerful control box with either traditional transformer solution or Switch Mode Power Supply. The universal Switch Mode Power Supply makes the control box adaptable to the worldwide market irrespective of the input voltage.

### Usage

Duty cycle:	10%, 2 minutes continuous use followed by 18 minutes not in use
Usage temperature:	+5 °C to +40 °C
Storage temperature:	-10 °C to +50 °C
Compatibility:	LA27 (no feedback/encoded feedback), LA31, LA34, LA43, LA44, BL1, and BL4
Approvals:	IEC60601-1 ANSI/AAMI ES60601-1 CAN/CSA-22.2 No 60601-1



### Recommendations

#### NOTE - HOT PLUGGING

Removing or adding any OpenBus™ cables are not allowed when the CB is powered by mains supply!

If needed anyway follow the below procedure:

1. Remove mains and wait 5 sec.
2. Mount or dismount the required cables

If this procedure is NOT followed it may result in a damaged OpenBus™ driver circuit.

The risk of a damaged circuit increases if the accessory has a high start current (in rush current).

#### NOTE - Use of internal mains signal in software or on OpenBus™

Please note when using the internal mains signal on control boxes with SMPS that the mains signal may take up to 6 seconds before disappearing after mains has been removed.

### Battery operation:

#### BATTERY LEVELS

Battery High: > 20 V	- normal
Battery Medium: 18 - 20 V	- alarm
Battery Low: < 18 V	- critical



If the battery voltage is at 'Medium level' a battery alarm beeps as long as a key is activated.

(Medium level means that battery charging is necessary to maintain the best possible lifetime).

- If the battery voltage is at 'Low level', the battery alarm function shuts down all movement immediately. The OpenBus™ is still active for approx. 15 seconds. (If trying to operate the system anyway, the battery could get deep drained or the actuator system could get damaged).
- When at low battery level (which is critical), there is a risk that the processor will incorrectly monitor the end of stroke.
- Crashing the actuator could be a result.
- The CB16 with battery back-up only commences battery charging when it is connected to the mains.
- For more information about the batteries, please contact LINAK.

### Before startup of CB16OBF

Due to the microprocessor in CB16OBF the control box has to be initialised before startup.

Initialisation will in most cases be possible pressing H0 and H1 or H10 and H11 on a hand control.

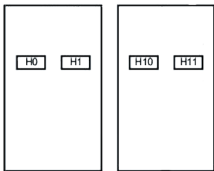

Initialisation depends upon the software description so please obtain a description of the initialisation procedure from your local LINAK dealer.

- If an actuator is replaced, the microprocessor always has to be initialised before use (actuators with reed/hall).
- If re-programmed please ensure that the correct software is used.



### Warnings

#### If backlight supported HB is used:

- When CB16 OBL or OBF is powered by mains voltage:

At no operation of the HB the backlight in the HB is dimmed.

If an HB button is activated the backlight illuminates fully.

When the HB button is released the light is dimmed again after approx. 10 - 15 sec.

- When CB16 OBL or OBF is powered by battery:

At no operation of the HB there is no backlight in the HB.

If an HB button is activated the backlight illuminates fully.

When the HB button is released the backlight turns off.



**1<sup>st</sup> failure safe monitoring:**

- Failure indication:

all ACO LED's are blinking

The CB16 buzzer is shortly beeping if a hand control is activated

The error can be reset by activating H0 and H1 OR H10 and H11 on a hand control.

**Compatibility – CB16 OBL:**

- Using actuators with feedback on CB16 OBL are not supported. If used anyway it will not work properly. The reason is that feedback signals (e.g. Hall signals) is positioned at the same PINS as analogue stop signals - when using no feedback.

**CB16OBF SMPS - Actuator combinations and/or customized software**

- Due to the high power from the CB16OBF SMPS, it is highly recommended to validate the system to guarantee the lifetime of connected actuators. Especially when using customized software and/or actuator combinations which do not comply with the LINAK compatibility list - for further questions please contact your local LINAK contact.



## CB20

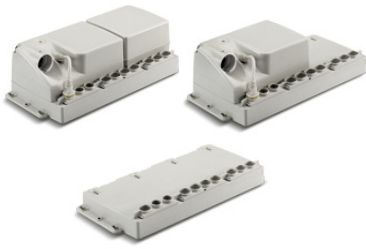

CB20 is a platform which offers a unique safety concept, logging off service data and it is possible to connect a variety of accessories to the control box.

CB20 consists of 3 modules:

- CP20 = Control Power
- CU20 = Control Unit
- BA20 = Battery

### Usage

Compatible with specific versions of LA23, LA27C, LA31, LA34, LA40, LA43, LA44 and BL1

- Duty cycle: 10% ~ max. 2 min. continuous use followed by 18 min. not in use
- Ambient temperature +5° to + 40°C
- Approvals: IEC60601-1, ANSI / AAMI ES60601-1, CAN/CSA-22.2 No 60601-1



### Information

CB20 is delivered in 3 separate units - CU20 + CP20 + BA20. The units are not assembled at LINAK A/S.



### Recommendations

#### HOT PLUGGING

- Removing or adding any OpenBus™ cables are not allowed when the CB is powered by mains supply! If necessary anyway follow the below procedure:
  1. Remove mains and wait 5 sec.
  2. Mount or dismount the required cables
 If this procedure is NOT followed it may result in a damaged OpenBus driver circuit. The risk of a damaged circuit increases if the accessory has a high start current (in rush current).
- Please note mains cable must be ordered separately.

#### Battery running

- If battery capacity is under 50% a “bip” sound is given for 2 seconds, when a handset key is pressed.
- If the system is activated and the mains plug is pulled out, the system will stop.
- In the opposite case, if the system is running using battery power and the mains plug is then plugged in, the system will continue running.
- The charging indicator can blink if the system operates with a high load causing the voltage to drop and because of this the batteries will start to charge.
- The CB20 with battery back-up only commences battery charging when it is connected to the mains.



## COBO



The COBO is an interface box specially developed to connect a 24 V battery pack and the CU20 control unit. It is also possible to connect other 24 V lead-acid customer batteries or fixed power supply.

### Usage

COBO with internal charger: Nominal current draw max. 400 mA  
Power consumption (standby) max. 2.5 W  
Power consumption (charging) max. 19 W

Compatibility: LINAK Batteries BAJ1, BAJ2 (24V, 2.9AH) or other 26-28V power sources via customer battery connection.  
LINAK Lithium Ion battery (BAJL Li-Ion)

Duty cycle: 10% 2 minutes running and 18 minutes rest

Operating temperature: +5 °C to +40 °C

Storage temperature: -10 °C to +50 °C

Relative humidity: 20% to 80% – non-condensing

Atmospheric pressure: 700 to 1060 hPa

Meters above sea level: Max. 3000 meters

Approvals: IEC60601-1  
ANSI/AAMI ES60601-1  
CAN/CSA-22.2 No 60601-1  
The COBO is EMC designed.



### Information

The COBO has a monitoring circuit for the FET transistor. If the FET is damaged the CU20 will go into fatal error mode. In this case the COBO is defective and must be replaced.

### Functionality

COBO with internal charger has a green and a yellow light.

Diode colour	Functionality
Green is on	COBO is connected to mains
Yellow is on	COBO is charging. The yellow LED is constantly on until batteries are fully charged.

The CU20 will shut down after 2 minutes to save power.

Accessories depending on V-permanent when the system is inactive will not work.

The CU20 controls whether or not activation should be allowed during charging.

Please note that the CU20 SW must ensure that there is no movement during charging when using COBO with internal charger.



**Guidelines regarding emergency STOP and battery state re-calibration:**

- The emergency stop button is not designed to be used as an on/off button.
- When using the emergency stop button, the system may shortly not be ready for use:
  - In normal situations waiting time for restarting the system is less than 5 seconds
  - In situations of shortly activating and then deactivating the emergency stop, the waiting time for battery state re-calibration can be up to 30 seconds.
- If a handset key is pressed during the re-calibration period, the control box may indicate with an audio signal, that the SW measures the battery condition. The user must wait until the re-calibration is finalised to be able to operate the system again.

**Mounting**

Special care should be taken when mounting the COBO.

As long as the COBO is mounted correctly then the COBO complies to IPX5 (IPX4 with internal charger).

If the COBO is mounted incorrectly then water will gather around the screw holes resulting in non-compliance with IPX5.

When using the control box with emergency stop, the stop button must be activated in cleaning situations in order to comply with IPX5.

The battery pack BAJ1 or BAJL must not be removed in cleaning situations, doing so could result in non-compliance with IPX5.

If the COBO is fitted with option EC (DC poser connector), the protection plug ex. 00918174 must always be inserted to ensure IP protection, if the port is not used.

IP rating only applies when the battery is connected to the control box.

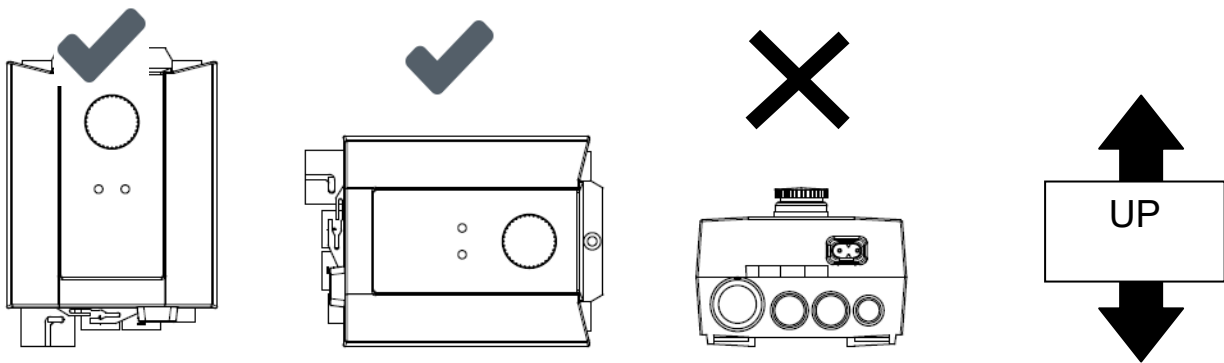



## Recommendations

- Choose CU200XXXXX2XXXX if positioning/memory function is to be used
- It is recommended that the COBO is serviced according to the relevant national norms for the applications in which it is used, however all electrical parts must be checked at least once a year
- The COBO should be cleaned regularly, in order to maintain good hygiene. Use of chemicals to clean the box is not allowed
- Only use COBO together with CU20
- When specifying special CU20 software, be sure to set "Operation allowed during charging" to YES, if customer batteries or fixed power supply is used



## Warnings

- Pay attention to the polarity of the customer battery cable - red is positive voltage
- In order to avoid injury, the emergency stop should be activated in (all) transport situations
- If 24V lead acid customer batteries or fixed power supply is used, the supply source must comply with "Means Of Patient Protection" and "Means Of Operator Protection" in accordance with the Medical Safety Standard
- If 24V lead acid customer batteries or fixed power supply are used, the customer must ensure that EMC values are kept in accordance with regulations
- The CU20 power port/channel 7 cannot be used with COBO
- Max 1 ACT can be connected to the COBO system
- The COBO is not to be used in agricultural or maritime applications or be connected directly to a vehicle battery



## COBO20



The COBO20 makes increased battery power available (compared to BA20). It is designed to be used with CU20 together with BAJ1 or BAJ2 (24V, 2.9AH). It is also

possible to connect other 24V lead acid or SLA (Sealed Lead Acid) battery types.

### Usage

The COBO20 is to be used with CU20 (instead of CP20) for applications that need a large battery capacity.

Operation temperature: +5 °C to +40 °C

Approvals: The COBO20 is EMC approved.

The COBO20 is designed in accordance with the following standards:  
60601-1/ UL2601 and EN60601-1-4.

When running on batteries CU20 will shut down after 2 minutes to save power.



### Recommendations

- Choose CU200XXXXX2XXXX if positioning/memory function is to be used.
- If a customer battery package is used, a 10A fuse must be added.
- After activation of emergency stop it can take up to 10 seconds before the system can be used again.
- It is recommended that the COBO20 is serviced according to the relevant national norms for the applications in which it is used, however, all electrical parts must be checked at least once a year.
- The COBO20 should be cleaned regularly in order to maintain good hygiene. It is not allowed to use chemicals to clean the box.
- Only use COBO20 together with CU20.



### Warnings

- In order to avoid injury, the emergency stop should be activated in all transport situations.

### Mounting of COBO20

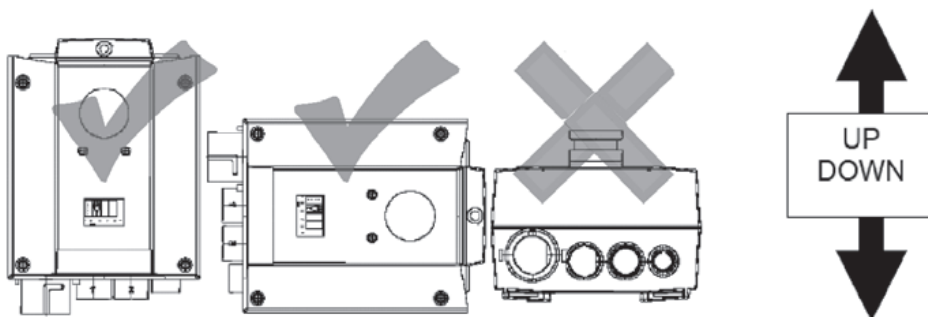

### Warnings

**Special care should be taken when mounting the COBO20.**

As long as the COBO20 is mounted correctly then the COBO20 complies to IPX5.

If the COBO20 is mounted incorrectly then water will gather around the screw holes resulting in non-compliance with IPX5.



## ACM



The ACM (Mini Attendant Control) box is fitted to hospital and care beds for use where patient positioning must be carefully controlled by the medical staff.

### Options

- 600 mm coiled cable
- Protection class IPX4 or IPX6, including lock ring for DIN-plug
- Charge indication: You must ensure that the chosen control box is able to supply the necessary signal to the charging light indicator.
  1. Indicating whether or not the battery is being charged (not possible for functionality 20 ).
  2. Functionalities 00 and 05 with charging indicator must not be used together with a CB which has channel 4 mounted.

### Blocking channels / Channel function

	= Lock function
<b>X</b>	= Not used

00 HB40-like

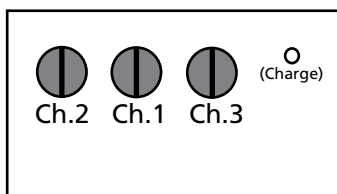

05 HB40-like

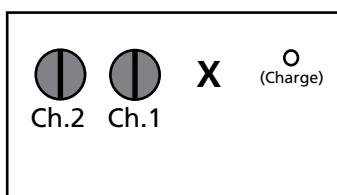

20 HB40-like

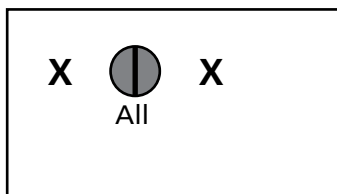

## ACT



The Attendant Control Touch (ACT) for the hospital and care segment is a control panel with an intuitive, graphical three-level user interface:

- Care mode for caregivers and relatives (bed operation)
- Extended care mode for caregivers (extended bed operation, features, settings)
- Service mode for technicians (advanced settings)

The ACT combines several operations and functionalities in one unit, thereby eliminating the need for several hand controls on the individual bed. In addition, the ACT is equipped with a large screen, giving the user a great overview of all the functions.

Software, graphics and front covers can be customised according to customer requirements. The ACT supports the LINAK OpenBus™ system offering a high level of customisation.

### Usage

Operation temperature:	+5 °C to +40 °C
Storage temperature:	-10 °C to +50 °C
Relative humidity:	20% to 80% – non-condensing
Atmospheric pressure:	700 to 1060 hPa (3000 meters)
Height above sea level:	Max. 3000 meters
Approvals:	IEC60601-1 ANSI/AAMI ES60601-1 CAN/CSA-22.2 No 60601-1
Compatibility:	Compatible with all OpenBus™ control boxes. Please contact LINAK.



### Recommendations

- Always use the cable locking mechanism and an O ring.
- Prepare a system/bit overview as the unit may conflict with other OpenBus™ accessories, HBs and attendant controls.
- Avoid large metal parts in the vicinity of the RFID reader (approx. 50 mm).
- When designing the application, be aware of the ACT position in the application to avoid impact to the front glass.
- Use a LINAK magnet or a magnet with a minimum strength of 15 mT measured at a distance of 10 mm.
- Do not bend the cable more than the minimum bending radius of 10 mm when mounting the ACT in side rails or similar where the cable is repeatedly bent.
- Before first start-up, be aware not to place any magnetic devices or RFID tags in front of the company logo until the ACT goes into sleep mode to avoid calibration disturbance.
- Be aware that magnetic jewellery or magnets in general can activate care mode and lead to unintended use. LINAK recommends to use RFID tags.



## Warnings

- The application manufacturer must write an end-user manual based on the LINAK user manual which also includes relevant warnings, information on how to carry out regular inspection and a functionality description. End-users must be trained in all functions.
- Regular system inspections for wear or damage must be made.
- Mains and battery power must be disconnected before servicing.
- Using the magnet key cannot wake up a green system or a system running on battery. The system will wake up when activating a key and the magnet key can then unlock the system.

## Mounting instructions

The ACT must be mounted on the bed, for example on the footboard - illustration of the fitting is shown below. The ACT must be supported on the back of the housing when fastening it to the mounting plate and not only supported on the edge of the housing front side.

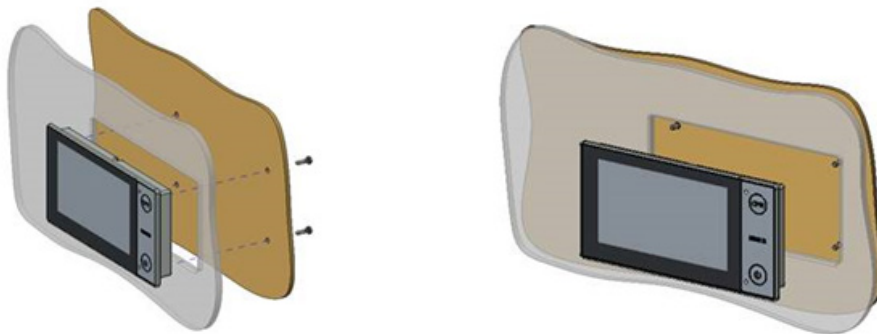

### When mounting:

- LINAK recommends to use a self-tapping screw, BN84229, 50x12.
- Please observe that the 1.5 [Nm] screw torque limit is not exceeded.
- Please be aware that the screw holes in the ACT are only 11 mm deep. Use appropriate screws.
- Please ensure that the mounting leaves space (2 mm) between the ACT and the back of the housing. This to avoid that water is trapped. The space is only necessary where the membrane is placed on the ACT.
- If upward cable exit is used, mount a ferrite core to the cable (see section "Ferrite core").

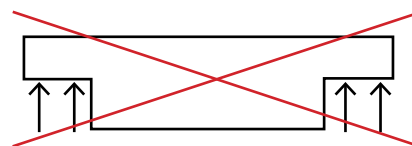
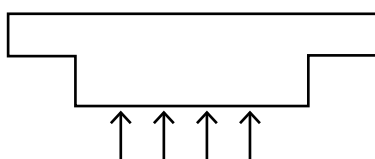
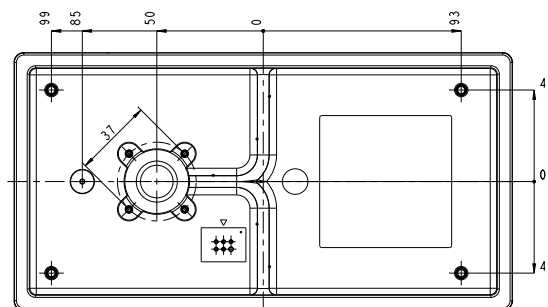

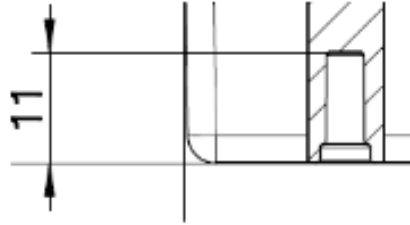

**Ferrite core**

If upward cable exit is used, a ferrite core needs to be added as close as possible to the ACT.

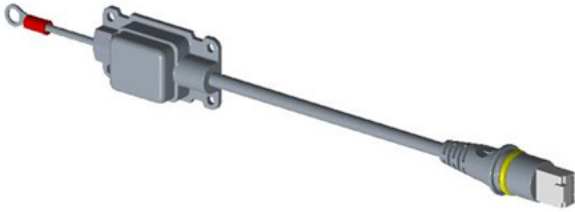

**Ferrite core specification**

At the mentioned frequencies, the impedance must be as stated in the table:

Frequency (MHz)	10	25	100	250
Impedance ( $\Omega$ )	95	156	260	270

Ferrite core graphic characteristics:

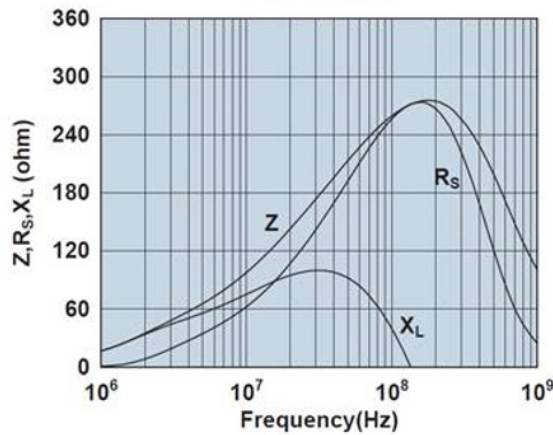

Impedance, reactance, resistance vs. frequency



## FS2



The FS2 Foot Switch is developed for use together with LINAK control boxes and especially designed for mounting on a support plate.

The Foot Switch is available in a single and a double version.

The double version can be used on a bed where one Foot Switch will be mounted on each side of the bed frame, thus enabling operation from both sides.

## HB20



The MEDLINE & CARELINE HB20 is for use with the IRO OpenBus™.

There are up to 12 buttons, enabling the MEDLINE & CARELINE HB20 to be used for almost all kinds of MEDLINE & CARELINE applications.

The hand control series is compatible with OpenBus™ Control boxes via Infrared Receiver Openbus (IRO). The HB20 series combines ergonomic design with a wide range of functionalities by means of infrared communication.



### Recommendations

- Do not submerge the hand control under water
- Unless otherwise specified or agreed with LINAK, the hand control is only intended to be used on LINAK systems
- Do not sit or lie on the hand control. It can cause unintended movement of the application
- Note that the operational distance is approx. 10 metres from the receiver when no interference between transmitter and receiver
- Light sources (38KHz +/- 5%) as e.g. neon light, sunlight or other light sources may interfere and cause a temporary stop in any movement
- Please keep the hand controls located to the application for which they are intended otherwise unintended movement may occur
- The functionality stops when objects block the communication between the IRO and HB20



### Warnings

- Inform the customer not to exceed the IP degree and to make regular inspection for correct functionality. Defective and worn-out parts must be replaced
- Inform the customer of correct touch button use to avoid unintended movement when buttons are frozen and therefore continuously activated
- Inform the customer that there is no low-battery indication. At low battery, the infrared range is reduced and it is recommended to replace the batteries. After battery replacement, the functionality and infrared range must be tested
- Inform the customer that all IROs that receive the HB20 signal will operate. It is not possible to pair HB20 with a certain IRO

## HB40



The HB40 series hand controls are designed for use with LINAK control boxes. These sturdy compact units are ergonomically designed and ideal for a vast range of applications from patient care beds and office furniture to industrial and agricultural duties.

### Usage

- Ambient temperature: +5° to +40° C
- HB40 is compatible with CB8-T, CB9..AX(not CH.4) and CB12 (not CH.4)
- HB40A is compatible with CB8-A battery version. Fitted with plug for battery charger CH01.
- HB40E is compatible with CB9Px (except CB9..PM/PN) and CB14
- HB44H is only compatible with CB9..Ax and CB12 (if CH.4) 4 channels
- HB40T is only compatible with CB7 ( max. 2 channels )
- Approvals, see Lintra/Development/Certificates

### Compatibility

	CB7	CB8	CB8A	CB9..Ax	CB9..Px (not CB9.. PM/PN)	CB12	CB14
HB4xO		x		x*		x*	
HB4xA			x				
HB4xE					x		x
HB4xH				x(4ch.)		x(4ch.)	
HB4xT	x						

\* = Only for channels 1, 2, and 3.

## HB50



The HB50 is primarily designed for the LINAK JUMBO system and LINAK control boxes with memory functions. The HB50 gives the user access to a range of memory functions, allowing present positions to be stored. For use in a wide variety of hospital, patient care.

### Usage

- Ambient temperature: +5° to +40°
- HB50B is compatible with CBJ2
- HB50E is compatible with CB09P..Px types(except ..PM/PN) and CB14 with memory
- HB50J is compatible with CBJ1



## HB60



The HB60 series is exclusively designed to be used together with the LINAK Homeline® system: LA31 / LA29 / CB7 or CB9 with or without memory.

## HL80



The HL80 hand control has an optimised ergonomic design and switch activations.

The HL80 is a lockable hand control, which makes it possible to lock or unlock one or several functions.

It is available in several different standard versions with a variation of bed symbols for easy interaction with end-users.

## Usage

Approvals: IEC60601-1, ANSI/AAMI ES60601-1 and CAN/CSA-22.2 No 60601-1



## Recommendations

- Violent use of the key on HL80 can cause either damage to the keyhole or the key itself.
- If a lock key is missing, then full control over the application could be missing.
- Clean the hand control regularly to ensure good hygiene standards.
- When a defective HL80 is replaced, check that the new HL80 has exactly the same specification and functionality.
- Do not submerge the hand control under water.
- Unless otherwise specified or agreed by LINAK, the hand control is only intended to be used on LINAK systems.
- When changing hand controls for OpenBus™ systems, the power must be switched off
- It is recommended to check the hand control and cable for damage and holes made by violent handling before washing the application or at least once a year.
- It is recommended to have a parking place for the hand control on the application, where the customer ensures that the hand control does not fall off.

For hand controls with magnet:

- If hand controls with magnet are attached to a smooth surface, a movement or twisting of the cable, for example during transport, can cause the hand control to move and result in damage if the cable is squeezed.
- The force of the magnet depends on the thickness of the lacquering, the lacquering type, stickers, steel thickness etc. It is the responsibility of the customer to verify that the holding force on the application is acceptable.
- It is the responsibility of the user/operator to evaluate any possible risk caused by use of permanent magnets.





## Warnings

- Do not sit or lie on the hand control. It can cause unintended movement of the application.
- When using the locking function on HL80, check that the hand control switches are actually locked.
- Locking function on HL80 only locks the actual hand control.
- Locking of a single channel on HL80 does not necessarily prevent this channel from activation, if the same channel is covered by another hand control button (e.g. at simultaneous drive) or another control unit.
- There is a risk that items with internal magnet for mounting instead of hook can disturb function of cardiac pacemaker, implantable cardioverter defibrillators or magnetic implants.

## IRO



The IRO (Infrared Receiver OpenBus™) has been developed as part of the accessory portfolio available to the LINAK OpenBus family and can be used for almost all kinds of MEDLINE® & CARELINE® applications.

The receiver can for example be connected to a bed so that the bed movement can be controlled with signals received from a remote control, the LINAK HB20. The combination of the IRO and the HB20 makes it possible to operate several applications with only one hand control.



## Recommendations

- The IRO does not operate when the control box runs on batteries in standard version
- Only one infrared device is recommended per application
- Always use locking ring and cables with O-rings (must be fitted to ensure IP degree)
- A correct and protected mounting, a clean and undamaged infrared window, as well as no blocking of the visual line between the receiver and the transmitter are necessary in order to assure optimal visual receiving ability
- Follow the mounting instructions



## Warnings

- Other equipment that uses a protocol similar to the LINBUS protocol for communication may have influence on the application operation
- Light sources (38 kHz +/- 5%) as e.g. neon light, sunlight or toys may interfere and cause a temporary stop in any movement



## BA19



The BA19 lead acid backup battery has been developed specifically for use with the new control boxes CA30/CA40 and CO61. It is a compact and cost-efficient battery with built-in charger and cable management.

### Usage

Duty cycle:	10%, 2 minutes continuous use followed by 18 minutes not in use
Charging:	Via integrated charger
Charging time:	Approx. 6 hours
Recharging during storage:	Battery recharging no later than 6 months after production date stated on the label
Operating temperature:	+ 5 °C to + 40 °C
Storage temperature:	- 5 °C to + 40 °C
Relative humidity:	20% to 80% - non-condensing
Atmospheric pressure:	700 to 1060 hPa (3000 m)
Height above sea level:	Max. 3000 meters
Service:	Battery cells cannot be replaced as the battery cover cannot be closed properly afterwards
Approvals (pending):	IEC60601-1:2005 3rd edition ANSI/AAMI ES60601-1: 2005, 3rd edition CAN/CSA-22.2 No. 60601-1:2008

### LED functionality:

What does the LED indicate?



LED	Indication of operation
Solid orange	Charging (battery not ready)
No LED light	Fully charged (battery ready)
Flashing yellow	Error during charging

### Buzzer functionality

The buzzer will make a warning when a button on the hand control is pressed and the battery capacity is low.

The buzzer can also be activated by the control box to signal other conditions. This must be specified in the control box software.

## Mounting instructions

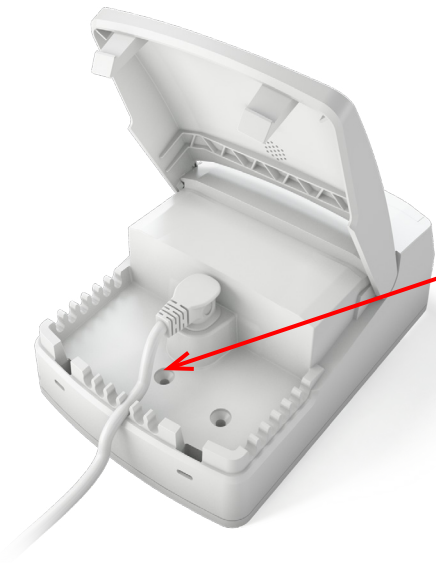

BA19 must be mounted with attachment screw and mounting bracket (see below) due to the battery weight.

Screw M4 countersunk  
torque 1.1Nm +/- 0.1Nm.

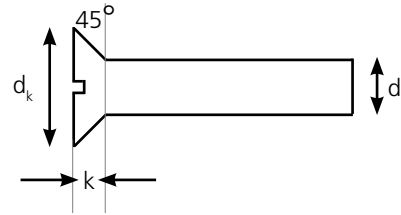

d	M4
dk	8.4
k	2.7

According to ISO 2009

## Mounting bracket (frame flat) - article no. 1015W1001:

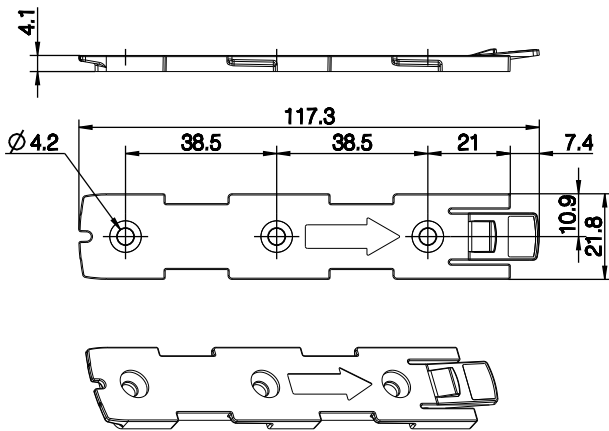



## Recommendations

- Do not exceed the storage temperature as it will shorten the product life and reduce performance.
- Allow the battery to settle to room temperature before use.
- Do not exceed the duty cycle 2/18 as it will shorten the life, reduce performance, and eventually activate overcurrent protection.
- BA19 is not intended for use in outdoor applications.
- If the battery is completely discharged, then recharge the battery before storage.

## Safety feature

- BA19 contains overcurrent protection for safety and to protect itself from being damaged due to excessive use.
- When current protection is activated no power output will be available.



## Warnings

- Loss of power might happen due to activation of overcurrent protection. In this event, there may be no warning and the application may not be able to move when expected.
- Defective or damaged batteries may leak acid and adequate precautions must be taken during handling and transportation.
- Do not open the battery case as damage to the cell or circuitry may develop excessive heat.
- It is important for users to read the guidelines in the “User Manual Linear Actuators and Electronics”.
- Do not short circuit the battery.
- Use the specified charger only.
- If disposed to fire, the battery may explode.

If product caution is not clearly visible on the final application at low light intensity, the above mentioned warnings must be integrated in the application manufacturer manual.

The application manufacturer must test the application and ensure that neither intended nor unintended use exceeds the battery specification. The application manufacturer must assure other means of movement, e.g. quick release or manual lowering in case of battery failure.



## Compatibility

The BA19 has a built-in charger and is therefore not able to operate with control boxes with charger. Be aware that the BA19 is compatible with CA30, CA40, CA63, CO41, CO61, CO65 and CO71.



## BA21



The BA21 Li-Ion back-up battery pack has been specially developed for use with the new control boxes COxx and CAxx, e.g. CO61 and CA40, etc. It is a low weight battery with built-in charger and high performance and safety.

### Features and options

Weight:	0.7 kg
Housing colour:	Light grey (RAL 7035)
Protection class:	IPX6 Washable DURA™
Packaging:	Every battery is packed individually and is fitted with lithium
Classification:	Internally powered
Approvals:	IEC60601-1 ANSI/AAMI ES60601-1 CAN/CSA-22.2 No 60601-1

### Usage

Compatibility:	Battery back-up for CO and CA control boxes
Duty cycle:	10%, 2 minutes continuous use followed by 18 minutes
Charging:	With integrated charger in battery
Charging time:	Approx. 10 hours
Recharging during storage:	First recharge of the battery must be no later than 12 months after production date stated on the label. Hereafter the battery must be recharged at least every 12 months.
Operating temperature:	+5 °C to +40 °C
Storage temperature:	-10 °C to +40 °C (+10 °C to +25 °C recommended) The batteries must be stored in an applicable storage room without direct sunlight.
Relative humidity:	20% to 80% - non-condensing
Atmospheric pressure:	700 to 1060 hPa
Height above sea level:	Max. 3000 meters
Approvals:	IEC60601-1 ANSI/AAMI ES60601-1 CAN/CSA-22.2 No 60601-1 IEC62133



## LED functionality



LED	Indication of operation
Solid yellow	Charging
No LED light	Fully charged
Flashing yellow	Error during charging

## Buzzer functionality

The buzzer will make a warning when a button on the hand control is pressed and the battery capacity is low.

## Mounting instructions

The Battery Pack BA21 can be mounted in several ways on the bed/the application, either separately or together with the control box CO61. It is however not allowed to mount the battery in vertical position with the mounting clip pointing upwards - see illustration below:

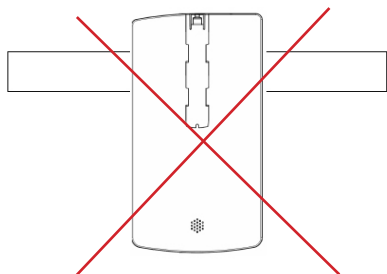



Disconnect the mains cable to the application at the power outlet. Remove the power cable from the control box by inserting a screwdriver into the locking clip marked.



Release the control box off the application by pressing the tab on the mounting clip.

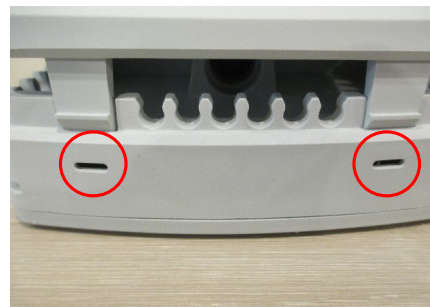

Open the lid to the control box by releasing the locking clips.

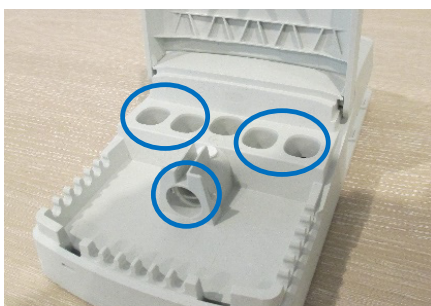

If you disconnect any actuator cables or hand control cables, please take note of the correct ports.



Open the lid to the battery box by releasing the locking clips.



Open the lid for access.

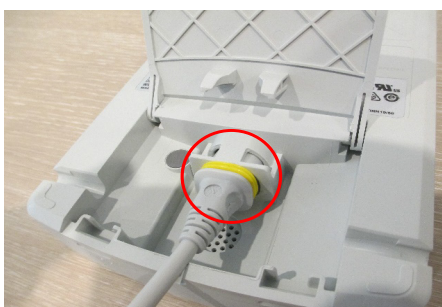

Insert the battery connection cable supplied in the battery port. Ensure that it is fully connected.

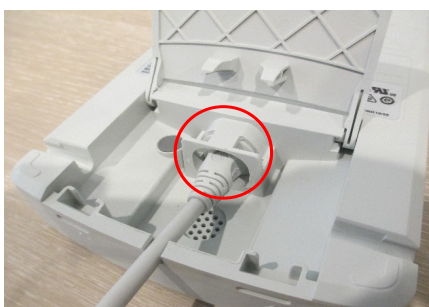

Close the lid, ensuring that the locking clips engage fully when securing the lid.



Connect the battery to the application, ensuring that the locking clip is fully engaged.

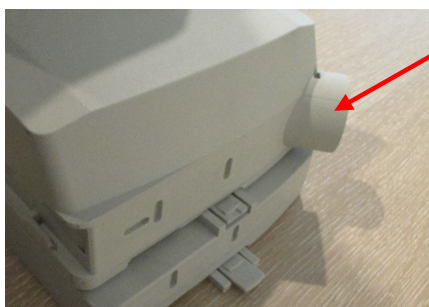

Connect the control box to the battery, ensuring that the locking clip is fully engaged.



If the clips are not engaged fully, the tab will be sticking out as indicated.

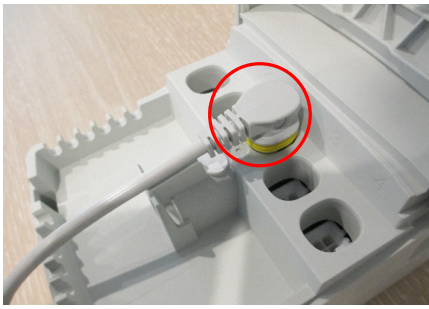

Insert the battery connection cable into the battery port in the control box. Ensure that it is fully connected.

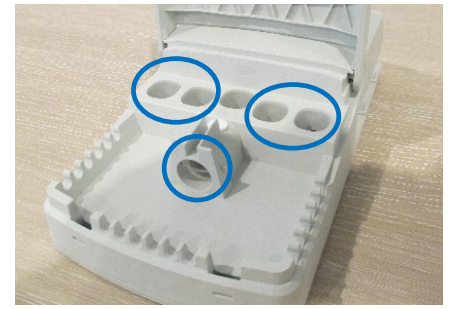
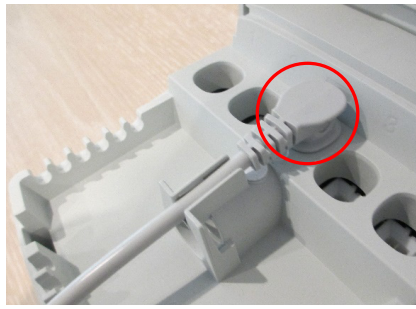

Reconnect any actuator cables or hand control cables to the correct ports.

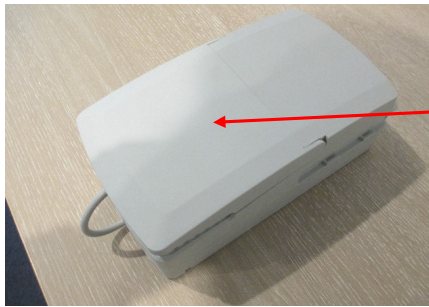

Close the control box lid, ensuring that the locking clips fully engage.



Reconnect the mains cable to the control box, ensuring that the locking clip engages. Turn on or reconnect the mains outlet.

## Deep discharge protection

- The BA21 Li-Ion has a deep discharge protection to protect the battery life. The deep discharge protection is activated when the battery is discharged.
- Charge the battery to exit the deep discharge mode. Ensure that the battery is sufficiently charged before use.

If the battery is completely discharged, the charging will be started at a very small rate to protect the battery. In this case the yellow LED will be flashing. If the battery does not stop flashing and start charging normally within 12 hours (LED ON), the battery is defect and must be disposed according to disposal instructions.

If any and all of the lithium ion batteries built into LINAK products are found to be defective under warranty, LINAK will provide a new product to the OEM. LINAK explicitly disclaims all other remedies. LINAK shall not in any event be liable under any circumstances for any special indirect punitive incidental or consequential damages or losses arising from any incident related to the inherent risk of thermal runaway in the lithium ion cell and any use of LINAK products. Moreover, LINAK explicitly disclaims lost profits, failure to realise expected savings, any claim against our customer by a third party, or any other commercial or economic losses of any kind, even if LINAK has been advised of the possibility of such damages or losses.

## Transportation

The lithium ion batteries must be packed and transported according to applicable regulations. Always ask your local transportation provider how to handle the transportation of lithium ion batteries.



## Recommendations

- Charge the battery fully before first use.
- Adhere to the battery storage temperature or else the lifetime and performance will be reduced.
- Allow the battery to settle to room temperature before use or charging.
- Adhere to the duty cycle or else the lifetime and performance will be reduced.
- BA21 Li-Ion is neither intended for use in outdoor applications, pool environments nor other harsh environments.
- Recharge the battery before storage if it has been completely discharged.
- Unintentional use of the emergency button, for instance short activation and deactivation of the emergency button after operating the actuators, can lead to an error indication of remaining battery capacity. The battery capacity will however be shown correctly approx. 20 seconds after activation of the emergency button.
- Only charge with applicable LINAK control boxes.

## Safety feature

BA21 Li-Ion contains several mechanisms to protect itself from being damaged due to excessive use.

In case of overheating, the device will activate a thermal protection. No power output will be available until the temperature has returned to normal operating range. Overheating may occur by extensive use at high temperature or by exceeding the 1/19 duty cycle.

## BA21 safety

LINAK Li-Ion batteries for medical use are designed and manufactured to be safe through the product life. LINAK has performed various tests of the batteries in normal use, abuse and failure situations to verify the design and production methods. These tests have not shown any unacceptable risks.

The batteries are UL-tested to have an independent organisation verify the safety of the design and to obtain a safety certificate. This means that UL regularly inspects the factory to check that standards are complied with.

UL has tested in accordance with the following standards:

UN38.3 Battery Transportation Safety

IEC62133 Battery Safety

UL2054 Standard for Household and Commercial Batteries



## Compatibility

The BA21 has a built-in charger which means that it cannot operate with control boxes with charger, e.g. CB6 and similar. The BA21 is compatible with CA30, CA40, CA63, CO41, CO53, CO61, CO65 and CO71.





## Warnings

All Li-Ion battery users must read these important battery safety instructions before using Li-Ion batteries. Failure to read and follow Li-Ion safety instructions and warnings may lead to personal injury and equipment damage if the battery is charged and/or used improperly.

Lithium ion batteries differ from the lead acid technology as they have a built-in deep discharge protection.

- In case of continuous use despite warnings, a power loss might occur due to the battery deep discharge protection. In this event, there may be no warning and the application may not be able to move when expected.
- The application manufacturer must test the application and ensure that intentional and unintended operations do not exceed the battery specification limits. The risk analysis for the final application must allow for the ensurance of alternative means to make movement, for instance quick release or manual lowering.
- If product caution is not clearly visible at low light intensity, read the product label instructions symbol. A warning must be included in the application manufacturer's manual for the medical device.
- Do not open, disassemble or modify the battery housing as cell or circuitry damage may develop excessive heat.
- Discontinue the battery use immediately if the battery emits an unusual smell, feels hot, changes colour or shape, shows signs of damage or corrosion or appears abnormal in any other way.
- In case the battery turns hot, disconnect and remove the battery from the room. If not possible to remove the battery, then evacuate the room.
- Defective or damaged lithium ion batteries or batteries that produce excessive heat or fire are not allowed for transportation.
- For safety reasons, please adhere to the indicated charging, storage, and operation temperature as extreme temperatures (low or high) might ignite the batteries and cause fire.
- The mounting instructions must be followed in order to avoid exposing batteries to water.
- The customer is responsible for determining that charger and host device work properly.
- Recharge batteries every 12 months at a minimum.
- Dispose of batteries in accordance with local regulations.

### DO NOT:

- heat, burn or short circuit the batteries
- expose the batteries to high impact
- crush or puncture the batteries
- charge or store the batteries near combustible material
- charge the batteries without supervision
- expose the batteries to water or other liquids

Any of the above mentioned can cause fire or injury.

LINAK® will remedy defective Li-Ion batteries built into LINAK products in accordance with the terms stipulated in the LINAK Li-Ion battery disclaimer available on the LINAK website. LINAK explicitly disclaims all other remedies and liability.



## CBJ1



The control box CBJ1 is part of the battery driven JUMBO system. JUMBO is a modular system combining an actuator, a control box (CBJ1), a battery (BAJ) and a charger (CHJ2) in a flexible solution, specially developed for patient lifts.

The complete system is medically approved and contains a series of features which meet the patient's need for a safe and comfortable lift; for instance, CBJ1 is equipped with a soft-start/stop function, emergency lowering function etc.

CBJ1 is available in a special edition that can be used in the harsh conditions in the pool environment both outdoor and indoor.

### Usage

CBJ1/CBJ2 with internal charger:

Nominal current draw max. 400 mA

Power consumption (standby) max. 2.5 W

Power consumption (charging) max. 19 W

Duty cycle:

max. 10% or 2 min. continuous use then 18 min. without use

Operation temperature:

+5 °C to +40 °C

Storage temperature:

-10 °C to +50 °C

Relative humidity:

20% to 80% – non-condensing

Meters above sea level:

Max. 3000 meters

Approvals:

IEC60601-1

ANSI/AAMI ES60601-1

CAN/CSA-22.2 No 60601-1

For one or two actuators (lift and leg spreader actuator)



### Recommendations

- The mains cable must always be ordered separately when ordering a CBJ1, CBJ2 with an internal charger.
- Use only original LINAK mains cables to ensure proper connection to internal charger.
- When charging, the CBJ1, CBJ2 will not be able to operate any actuators.
- By use of charger CH01 it is possible to activate the actuators when charging. However, this is not recommended as it can damage the control box or the charger CH01.
- When the CBJ1, CBJ2 with LCD display option is combined with the battery BAJ Li-Ion, the LCD display can indicate empty battery, even if the battery capacity is not low. The acoustic alarm will always be activated at low battery capacity independent of display indication.





### Warnings

- In order to avoid injury, the emergency-stop should be activated in (all) transport and cleaning situation.
- BAJ Li-Ion batteries differ from BAJ1 lead acid as they have built-in discharge protection. If the user continues to use the battery despite warning signals, loss of power might happen due to the battery deep discharge protection. In this event, there may be no warning and the application may not be able to move when expected.
- The combination of CBJ1 or CBJ2 with BAJL might not be able to complete a full cycle after low battery warning.



**Current cut-off for CBJ1**

CBJ1	CH1 				CH1 				Leg spreader CH2	
	Up		Down		Up		Down			
	Min.	Max.	Max.	Min.	Min.	Max.	Max.	Min.	Min.	Max.
CBJ1001N	6.3	8.3	5	3.3	*	*	*	*	-	-
CBJ1001H	9	11.5	7	4.7	6.3	8.8	7	4.7	-	-
CBJ1002N	6.3	8.3	5	3.3	*	*	*	*	2	2.9
CBJ1002H	9	11.5	7	4.7	6.3	8.8	7	4.7	2	2.9
CBJ1004H	5.25	6.3	3.85	2.75	5.2	7.1	5	3.3	4.7	6.2
CBJ1005N	6.3	8.3	5	3.3	*	*	*	*	4.7	6.2
CBJ1005H	9	11.5	7	4.7	6.3	8.8	7	4.7	4.7	6.2

\*Current cut-off depends on motor type due to pulse width modulation.

**Warnings**

When plugging a mono jack plug into channel 1 the current cut-off will be as the high speed table.

**Current cut-off for CBJ2**

CBJ2	CH1		Leg spreader CH2	
	Min.	Max.	Min.	Max.
CBJ2001N	7	9	-	-
CBJ2001H	9.8	11.8	-	-
CBJ2002N	7	9	2	2.9
CBJ2002H	9.8	11.8	2	2.9
CBJ2003H	4.9	5.9	-	-
CBJ2004H	4.9	5.9	4.7	6.2
CBJ2005N	7	9	4.7	6.2
CBJ2005H	9.8	11.8	4.7	6.2
CBJ2006H	<b>9.8</b>	<b>11.8</b>	-	-
CBJ2007H	9.8	11.8	2	2.9
CBJ2008H	9.8	11.8	4.7	6.2

The minimum and maximum values stated above refer to the tolerance range, not the adjustment range.

The current cut-off tolerance is +/- 0.2 A depending on the ambient temperature (20 °C).

**Warnings**

To avoid injury, all control boxes with variable current cut-off are preset to < 4 A, unless otherwise specified.



## Adjustment instructions for the JUMBO application

Tool	For the adjustment you must use a trimming screwdriver, which can be purchased from LINAK A/S. It is also possible to use other types of trimming screwdrivers for the adjustment. Ordinary screwdrivers cannot be used, as they will damage the potentiometer slot. When you receive the JUMBO from LINAK A/S it is adjusted to min. current cut-off, see page 7.
1.	Connect the JUMBO control box to the actuator.
2.	Load the actuator with the required load.
3.	Turn the potentiometer completely clockwise.
4.	Run the actuator in the loaded direction at the same time turn the potentiometer anticlockwise until the actuator stops.
5.	Turn the potentiometer 3 times clockwise.
6.	Check JUMBO can lift the loaded actuator.
7.	Insert the plugs article no. 0009020 (light grey, RAL7035) or 0009019 (dark grey, RAL 7016) to ensure IP protection.

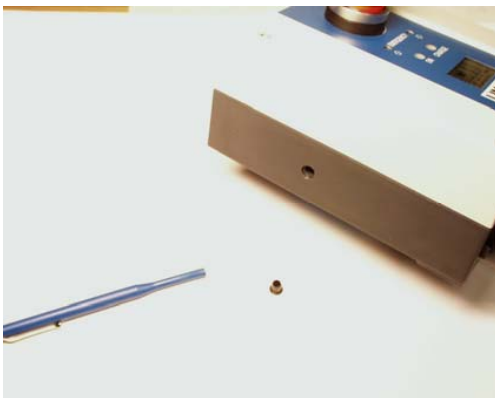

Only the end with the lowered notch must be used for adjustment of the potentiometer.

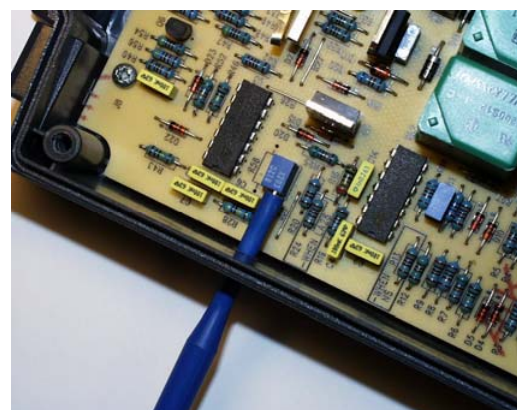

## Mounting the CBJ1, CBJ2

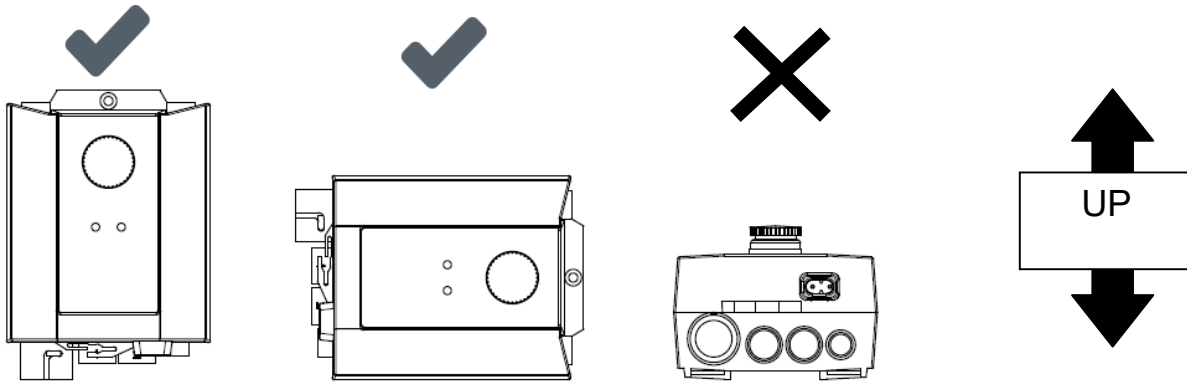

### Warnings

#### Special care should be taken when mounting the CBJ1

As long as the the CBJ1 is mounted correctly then it complies to IPX5.

If the CBJ1 is mounted incorrectly, then water will gather around the screw holes resulting in non-compliance with IPX5!

CBJ1 with variable current cut-off: the protection plugs must always be inserted to ensure IP protection after adjustment.

When using the control box with emergency stop, the stop button must be activated in cleaning situations in order to comply with IPX5. The battery pack BAJ1 must not be removed in cleaning situations, doing so could result in non-compliance with IPX5.

If the CBJ1 is fitted with option B, D and F (DC power connector), the protection plug ex. 00918174 must always be inserted to ensure IP protection, if the port is not used. IP rating only applies when the battery is connected to the control box.

## EBC



The EBC - Electronic Brake Control - is designed for use together with 3rd party castors and the control systems CB OpenBus™, including Jumbo Care. The EBC can replace traditional (mechanical) central locking systems for castors on healthcare beds or medical applications. This new system offers an increased freedom of application design as there is no need for a mechanical connection between the castors.

### Usage

Operation temperature:	+5 °C to +40 °C
Storage temperature:	-10 °C to +50 °C
Compatibility:	Compatibility: CBJC, CB6 OBF, CB6 OBMe, CB16 or CB20
Approvals:	Fallshaw EBC system approved according to IEC60601-1:2005 3rd edition approved, ANSI / AAMI ES60601-1:2005, 3rd edition, and CAN / CSA-22.2 No 60601-1:2008 Manner/TENTE approvals are pending



### Recommendations

- The customer shall ensure proper connection between the EBC and the castors. Missing or interrupting some of the individual wires between the EBC and the castor may under some circumstances cause damage to the internal circuitry of the EBC.
- Always use locking mechanism and O-ring on cables.
- If any open sockets, they must be fitted with blind plugs to ensure IP degree.
- Removing or adding any OpenBus™ cables is not allowed when the CB is powered (hot plugging).

#### Before installation/service

- Stop the application.
- Remove battery power cable and OpenBus™ connection then possible castor connection.
- Service system.

#### After installation/service

- Reconnect castor connection, then OpenBus™ connection, battery power cable, then CB mains.



### Information

LINAK A/S only delivers the OpenBus system and is not responsible for any products other than LINAK products (i.e. products from 3rd party suppliers or the compliance of such products with the LINAK OpenBus system).



## MJB8



The MJB8 modular junction box is a central unit in the “Intelligent Care Bed”, connecting various intelligent accessories, such as the Out Of Bed and WET detection, and sending notifications via a range of optional gateways to the user (i.e. caregiver)



### Recommendations

- Always use locking mechanism and O-ring
- Sockets that are not used must be fitted with blind plugs (Item P/N.: 0821008) to ensure IP-degree
- When using the modular plug cable with an open end, the customer is responsible for maintaining the IP degree
- When mounting, ensure that a screw torque limit of 1 Nm is not exceeded
- 3rd party products must correspond to all requirements stated in the MJB8 Interface description for 3rd party products (see SBU chapter 10.21) in order to avoid damage/malfunction
- The Under Bed Light (Item P/N.: 0964135) must be mounted on the bed with metal screws in order to maintain ESD protection
- HOT PLUGGING

Removing or adding any OpenBus™ cables are not allowed when the control box is powered by mains supply!

Follow the below procedure:

1. Remove mains and wait 5 seconds
2. Mount or dismount the required cables

If this procedure is NOT followed it may result in a damaged OpenBus driver circuit.

The risk of a damaged circuit increases if the accessory has a high start current.

- Before the final functional production test, it is important that the system is re-powered. This is to ensure, that all items have been detected on the OpenBus.
- It is important to test the specified notifications in order to ensure that they work correctly before sending the system to the end user
- The MJB8 is intended for mains operation only. The user must be informed that all MJB8 sensor notifications are disabled when the system is in battery mode.



### Warnings

- LINAK only takes responsibility for LINAK products, not 3rd party products  
Please pay attention to the “Patient Environment” Clause 3.79 – EN60601-1 3rd edition. It must be subject to the Risk Analysis. It is important to inform the customer about this.
- The MJB8 is not able to detect defective 3rd party products. We recommend the end user to make a regular test procedure in order to prevent hazardous situations for the user and failures to the system.
- The MJB8 and the attached accessories (i.e. Out Of Bed or WET detection) are not intended as life-supporting or emergency equipment. They are only intended to support notifications for communication and comfort purposes of people in need of care.



## SCALE: QLCI1 and SCO



The Scale system is an overall LINAK article description for weight measuring comprising a display device (SCO = Scale Control Openbus™) and a calculation device for load measuring (QLCI = Quad Load Cell Interface). It is developed for the OpenBus™ product range.

### Specifications





Scale system (SCO / QLCI)			
<b>C.</b>	<b>COLOUR</b>	SCO: LIGHT GREY (RAL 7035) QLCI: TOP/BOTTOM = RAL7001 BASE = RAL7035	
	<b>CONTROL CONCEPT</b>	OpenBus™	VIA 6-POLE CABLE
	<b>COMPATIBILITY</b>	CB16 OBL, CB6/16 OBF, CB20, CO41, CO61 and CO71 (NOT CB6OBL)	
	<b>CURRENT CONSUMPTION</b>	SCO: 8 V POWER REQUEST: 0,5 mA 40 V PERMANENT SUPPLY: 38 mA QLCI: 8 V POWER REQUEST: 10 mA 40 V PERMANENT SUPPLY: 19 mA	
<b>M.</b>	<b>MEASURING RANGE</b>	MAX. 255 Kg (562 lbs) OR 460 Kg (1014 lbs) LOAD ON APPLICATION (SWL)	LOAD VERSION 460 KG IS OPTIONAL SWL = SAFE WORKING LOAD
<b>W.</b>	<b>WEIGHING CELLS</b>	4 PCS. OF LOAD CELLS REQUIRED (TYPE: 3mV/V); COMPANY ZEMIC LINAK ITEM >> NO.: TR-1081109 NAME: H8C-C3-500KG-3BG-SC	MUST BE 'OIML' APPROVED FOR APPROVED SYSTEMS (OIML = International Organization of Legal Metrology)





### Environment

Scale system (SCO / QLCI)		
<b>A.</b>	<b>AMBIENT TEMP.</b>	+5 to +40 C
<b>H.</b>	<b>HUMIDITY</b>	20% - 85% @ 40°C – not condensing



## Functionality buttons

	<p><b>[Enable] button:</b></p> <p>To activate and navigate the panel and all its functions, push the enable button and a selected function button simultaneously. This is a safety feature to avoid unintended usage.</p>
	<p><b>[Accuracy] button:</b></p> <p>The scale system can be set to show the weight in an accuracy of 500 g. By default the system is set to 500 g accuracy, but by activating this button you get a 100 g accuracy.</p> <p>The approval covers 500 g as default. 100 g only serves as guidance (not approved according to EN45501). The LED above the button will illuminate when 100 g (0.1 lbs) accuracy resolution is chosen by pressing the button. After approx. 5 sec. the accuracy resolution will return to default accuracy resolution.</p> <p>The accuracy resolution can only be toggled when no load is present AND after a measure is carried out (activation of the enable + scale button).</p>
	<p><b>[Scale] button:</b></p> <p>To measure the weight push the enable button and the scale button simultaneously. Max. measurement area 0 - 255 kg (optional 0-460 kg).</p> <p>Explanation of this function:</p> <p>Weight max = SWL - Auto Compensation - Zeroing = Actual weight of the patient on the display.</p> <ul style="list-style-type: none"> <li>• SWL = 255 kg (optional 460 kg)</li> <li>• Auto Compensation range = 0 - 100 kg</li> <li>• Zeroing range = 0 - 50 kg</li> </ul> <p>Example of display indication:</p> <p>Max. weight readout on display = 255 kg - 100 - 40 = 115 kg.</p> <p>The LED above the button will illuminate when button is activated.</p>
	<p><b>[Auto] button (Auto compensation):</b></p> <p>With the patient already in the bed this feature enables the staff to add or remove items from the bed - e.g. a pillow - without any influence on the weight of the patient.</p> <p>Max. auto compensate range is +/- 100kg.</p> <p>Auto compensation can be reset by unplugging mains (back to default) or zeroing the bed.</p> <p>Compensation procedure:</p> <ol style="list-style-type: none"> <li>1. At first activation of buttons 'Enable + Auto Compensation' the current weight is saved. The display says "AUTO" - and the LED for the button 'Auto Compensation' is flashing. When the LED stops flashing the weight is stable and the objective to compensate for can be added or removed.</li> <li>2. Repeating the activation of the buttons will compensate for the added removed load. When the LED is no longer flashing the procedure is finished and the display is empty.</li> </ol> <p>By renewed activation of the 'Enable + scale' buttons the display will show the weight measured before the compensation done - which equals the weight of the patient.</p> <p>If 'AUTO' compensation is enabled the 'AUTO' LED will illuminate when making a measurement via the 'Enable + scale' button.</p>

	<p><b>[Zero] button- MUST be carried out before patient enters the bed:</b></p> <p>To set the scale to <math>&gt;0&lt; = 0</math> kg (Zero), push this button. I.e. if a mattress is put in the bed, but you don't want to measure its weight, you can set the scale to <math>&gt;0&lt;</math> after the mattress has been put into the bed. Limit of zeroing is 50 kg. See example at "Scaling" function above.</p> <p>If "AUTO" compensation is enabled, it will be cancelled after a reset has been carried out.</p> <p><b>NOTE:</b></p> <p>It is possible to carry out <math>&gt;0&lt;</math> when added load on the application (after calibration) does NOT exceed 50 kg.</p> <p>I.e it will be possible to add different types of mattresses, linen and other, so far as the total load added does not exceed 50 kg.</p> <p>In case 50 kg is exceeded, the error code indicating "ZEROING RANGE" error will occur.</p> <p>In case parts are removed from the application (if side and/or head rails and mattress where mounted during calibration and then removed afterwards) the system will identify a load that is lower than the calibrated <math>&gt;0&lt;</math>. An error indication "INSUFFICIENT LOAD" / "BELOW CALIBRATED ZERO" will be the result.</p>
	<p><b>[Out of bed alarm] button (only active if connected to mains):</b></p> <p>By default this feature is disabled. This feature becomes active by activating the button with the patient in the bed. If the patient leaves the bed afterwards you get a constant buzzer alarm - as long as the volume level is set to at least level 1, and the button LED changes from green to red. The alarm is activated by 50% loss of weight on the load cells. Note that the signal can be transferred to a hospital network via a gateway unit.</p>
	<p><b>[Out of bed Volume adjustment] button:</b></p> <p>Adjust volume of the buzzer in 3 levels by pushing the volume button. The levels will be shown by the LEDs.</p>
	<p><b>(Unit) button - Kg/Lbs:</b></p> <p>The measure can be set in Kilo/Kg or in Pounds/Lbs</p> <p><b>(Unit) button - Kg:</b></p> <p>(The EU model; it is prohibited to use Pounds / lbs units in Europe)</p>
	<p><b>Display:</b></p> <p>To show the weight and info of the system, the display shows the data. The LED will light up for the chosen unit. Error codes can also be shown in the display. (see separate chapter for error codes)</p>

**NOTE re. all buttons on the SCO:**

- When calculation or adjustment of weight is on-going the display indication will be flashing until e.g. the weight calculation is stable. Approx. 20 sec. after the display shows a stable value it will shut-off (approx. 5 seconds at 100 g readout).
- The LED above a button will illuminate when the chosen button is activated.
- Activation of any button on the SCO will result in a beep, if the CB previously had a fatal error. The beep sound has no influence on the measuring result, i.e. the Scale system is independent of fatal errors in the control box.

**NOTE re. use of Enable + scale button during manufacturing:**

 The image shows two icons separated by a plus sign. The first icon is a square button with a grey circle in the center and a hand with the index finger pointing at it. The second icon is a scale of justice with a red LED indicator light above it.	<p>If pressing the Enable + scale buttons simultaneously for 10 sec. the SCO display will constantly display the weight. This may be a useful feature during the manufacturing and test process - because otherwise the SCO display will time out after approx. 20 sec. during normal operation.</p> <p>The function can only be reset by unplugging mains power.</p>
--	---

## Mounting guidelines, QLCI



Recommended placement



Not recommended

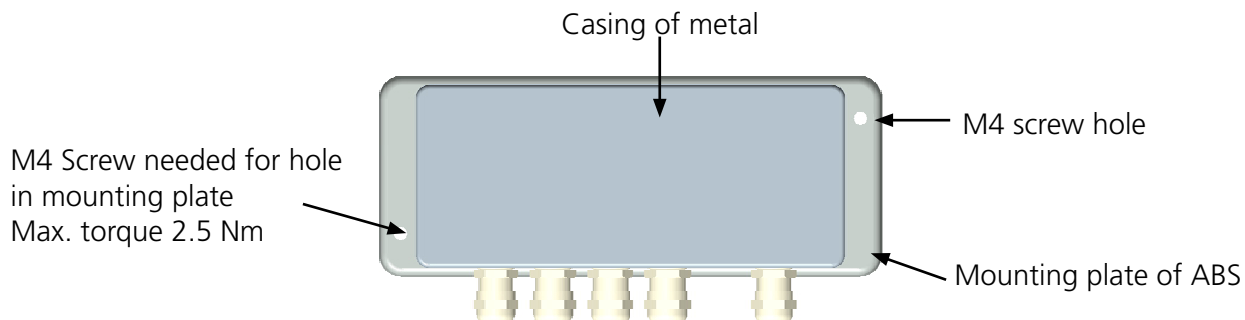

### Information

There must be no contact from application or metal to the aluminum box.

A minimum distance of 2 mm between metal parts MUST be kept!





This can be done by mounting of the QLCI cover (included in the SCO ordering ex.)

### Mounting instructions for weighing cells

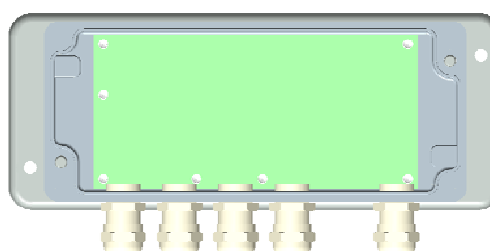
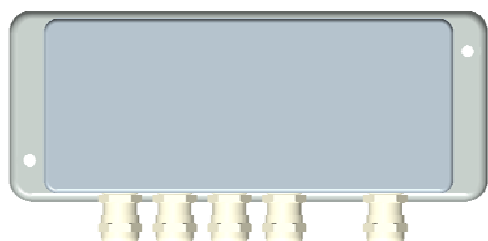
Remove the rubber band and open the lid.

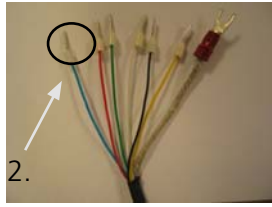
See instruction for mounting of cables for weighing cells and calibration inside the lid.

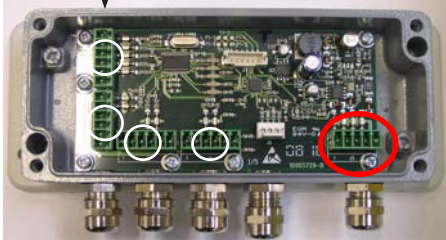

<p>1. Mount heat shrink on shield wires 2. Mount Bootlace Ferrules 0.5 White on wires</p>	
<p>3. Insert shield wire in screw near J1-J4. Torque 2 Nm</p>	
<p>4. Mount wires in plug as illustrated according to colour coding as shown on the inside of the QLCI lid. Torque of screws 0.5 Nm</p> <p>Observe placing of the four 6-PIN plugs no. 1052051 (see white circles) and wire colours as shown (left to right): red, blue, green, white, yellow, black.</p> <p>A 5-PIN plug (see red circle) is used as well. Wire colours (left to right): green, white, blue, black, red.</p>	 
<p>Colour coding: See instructions in QLCI top cover (lid). The Colour code J1-J4 refers to Zemic Weigh cell H8C-C3-500KG-3B6-SC only.</p>	
<p>5. Torque all PG fittings: 4.2 – 5 Nm Cable diameter 5 – 5.5mm</p> <p>6. Torque all LID screws: 2.5 - 3 Nm</p>	



## Recommendations

- The QLCI must be handled according to guidelines for electronic sensitive devices. This means that opening the QLCI box shall only take place in ESD-secured areas.

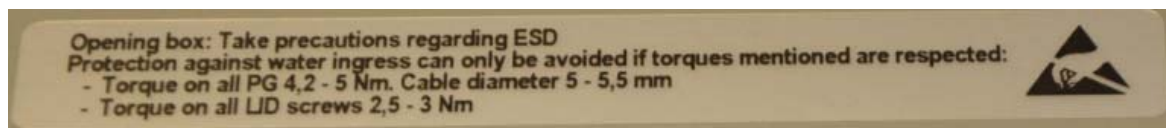

- The QLCI device is rated as IPX4 and must be mounted accordingly - see recommended mounting instructions.
- To avoid misleading weight calculations caused by differing voltage drops over the cables, it shall be ensured during assembly of the load cells that all load cell cables have the same length.

## Error codes description - and what to do:

If an error occurs, an Exxx code will be shown in the display.

User error	Interpretation/Troubleshooting	
8888	<b>'AUTO COMPENSATION'</b>	
	Indicated when 'Auto Compensation' is out of range.	
8888	<b>Failure</b>	<b>How to correct failure</b>
	<ul style="list-style-type: none"> <li>Too much weight added as compensation.</li> </ul>	<ul style="list-style-type: none"> <li>Add weight only from 0 - 100 kg</li> </ul>
8888	<b>'AUTO COMPENSATION'</b>	
	Indicated when 'Auto Compensation' is out of range	
8888	<b>Failure</b>	<b>How to correct failure</b>
	<ul style="list-style-type: none"> <li>Too much weight removed as compensation.</li> </ul>	<ul style="list-style-type: none"> <li>Remove weight only from 0 - 100 kg</li> </ul>
8888	<b>'ZEROING RANGE'</b>	
	Indicated when the accepted setting for zeroing is out of range (>50 kg) !The error message will be displayed until the error is corrected, but will timeout after 2 sec.	
8888	<b>Failure</b>	<b>How to correct failure</b>
	<ul style="list-style-type: none"> <li>'Zeroing Range' 0 - 50 kg not kept</li> </ul>	<ul style="list-style-type: none"> <li>Only add max. 50 kg on bed</li> </ul>
8888	SWL = 'Safe Working Load' Indicated if total weight of bed is exceeded.	
	<b>Failure</b>	<b>How to correct failure</b>
8888	<ul style="list-style-type: none"> <li>If measure of patient is compensated with 100 kg the SCO display area is narrowed to max. weight measure - 100 kg.</li> </ul> <p>Ex.: 255 kg - 100 kg = 155 kg. If the weight of the patient is &gt; 155 kg the display will indicate the shown fault.</p>	<ul style="list-style-type: none"> <li>Remove weight from the bed and make new 'Auto compensation'</li> </ul>
	<b>'BELOW CALIBRATED ZERO'</b>	
8888	Indicated if a weight measure goes below zero.	
	<b>Failure</b>	<b>How to correct failure</b>
8888	<ul style="list-style-type: none"> <li>If the weight of the bed is approx. zero and the bed hits an obstruction when running inwards the weight may become lower than zero.</li> </ul>	<ul style="list-style-type: none"> <li>Remove bed from obstruction or remove obstruction.</li> </ul>



Error code	Interpretation	Troubleshooting
E100	<ul style="list-style-type: none"> <li>- QLCI disconnected</li> <li>- Defective OpenBus™ cable</li> </ul>	<ul style="list-style-type: none"> <li>- Check that the QLCI is connected correctly to the bus system.</li> <li>- Check the Openbus cable: Connect an “ok” cable to the Openbus and green connector inside the QLCI\*.</li> <li>- Check the QLCI box: Connect an “ok” QLCI without load cell and check that E100 is removed but replaced by an E2xx instead. If this helps, the other QLCI is defective \*.</li> </ul>
E101	QLCI not calibrated	- The QLCI need to be calibrated.
E202	QLCI not calibrated	- The QLCI need to be calibrated.
E205	<p>Input from load cell 1 is missing so the following failure can be:</p> <ul style="list-style-type: none"> <li>- Load cell 1 disconnected or defective</li> <li>- Defective load cell 1 cable</li> </ul>	<ul style="list-style-type: none"> <li>- Unplug mains for re-powering and check if the failure is remedied.</li> <li>- Check load cell 1 cable/wires: Check if load cell 1 cable is intact and also the wires and green connector inside the QLCI \*. Check if E205 is remedied after the inspection.</li> <li>- Check load cell 1: Connect a “new” load cell and check if E205 is remedied \*.</li> </ul>
E206	<p>Reference signal for load cell 1 is missing so the following failure can be:</p> <ul style="list-style-type: none"> <li>- Load cell 1 disconnected or defective</li> <li>- Defective load cell 1 cable</li> </ul>	<ul style="list-style-type: none"> <li>- Unplug mains for re-powering and check if the failure is remedied.</li> <li>- Check load cell 1 cable/wires: Check if load cell 1 cable is intact and also the wires and green connector inside the QLCI \*. Check if E206 is remedied after the inspection.</li> <li>- Check load cell 1: Connect a “new” load cell and check if E206 is remedied \*.</li> </ul>
E209	<p>Input from load cell 2 is missing so the following failure can be:</p> <ul style="list-style-type: none"> <li>- Load cell 2 disconnected or defective</li> <li>- Defective load cell 2 cable</li> </ul>	<ul style="list-style-type: none"> <li>- Unplug mains for re-powering and check if the failure is remedied.</li> <li>- Check load cell 2 cable/wires: Check if load cell 2 cable is intact and also the wires and green connector inside the QLCI \*. Check if E209 is remedied after the inspection.</li> <li>- Check load cell 2: Connect a “new” load cell and check if E209 is remedied \*.</li> </ul>
E213	<p>Input from load cell 3 is missing so the following failure can be:</p> <ul style="list-style-type: none"> <li>- Load cell 3 disconnected or defective</li> <li>- Defective load cell 3 cable</li> </ul>	<ul style="list-style-type: none"> <li>- Unplug mains for re-powering and check if the failure is remedied.</li> <li>- Check load cell 3 cable/wires: Check if load cell 3 cable is intact and also the wires and green connector inside the QLCI \*. Check if E213 is remedied after the inspection.</li> <li>- Check load cell 3: Connect a “new” load cell and check if E213 is remedied \*.</li> </ul>
E217	<p>Input from load cell 4 is missing so the following failure can be:</p> <ul style="list-style-type: none"> <li>- Load cell 4 disconnected or defective</li> <li>- Defective load cell cable</li> </ul>	<ul style="list-style-type: none"> <li>- Unplug mains for re-powering and check if the failure is remedied.</li> <li>- Check Load cell 4 cable/wires: Check if load Cell 4 cable is intact and also the wires and green connector inside the QLCI \*. Check if E217 is remedied after the inspection.</li> <li>- Check load cell 4: Connect a “new” load cell and check if E217 is remedied \*.</li> </ul>



\\* Remember to unplug mains power when repairing!!

\* Error codes 2xx is only updated / cancelled by unplugging mains or carry out a reset of the Scale system.

NOTE: All user or error indications will time out after 20 sec. (except 'Zeroing range' error)

### Display explanation:





At self-check, automatic error detection will be made. If an error is found, it is possible to interpret it via the error / troubleshooting scheme on the previous page.

Below different messages are shown.

### Self check at power up, SCO unit

The Scale panel receives the weighing constant each time the panel starts up by using a function called 'Get calibration weighing constant'.

The QLCI has a delay after re-powering, so the Scale will start up after the display has indicated the following "-", "--", "---" and "----" as shown in the below figure:

	"-" One segment (centre) illuminated, shown first.
	"--" Two segments illuminated
	"---" Three segments illuminated
	"----" Four segments illuminated

There is a one second delay between indications.

### NOTE:

The Scale measurement cannot go below 0 kg during normal operation. However, if an obstruction occurs, when for instance a bed frame collides against a window frame, the bed starts pulling the bed frame down. This way the Scale system observes reduced load since part of the bed is still hanging against the window frame - theoretically therefore a weight below 0 kg is possible. If the Scale system observes/ measures lower than 0 kg, the indication shown above might occur - indication of an obstruction. If this kind of failure is observed, please check the Scale system for failures/obstructions.

## How to connect the Scale system

OpenBus™

(CB16OBL, CB6/16OBF, CB20)

SCO

Hand controls / ACx

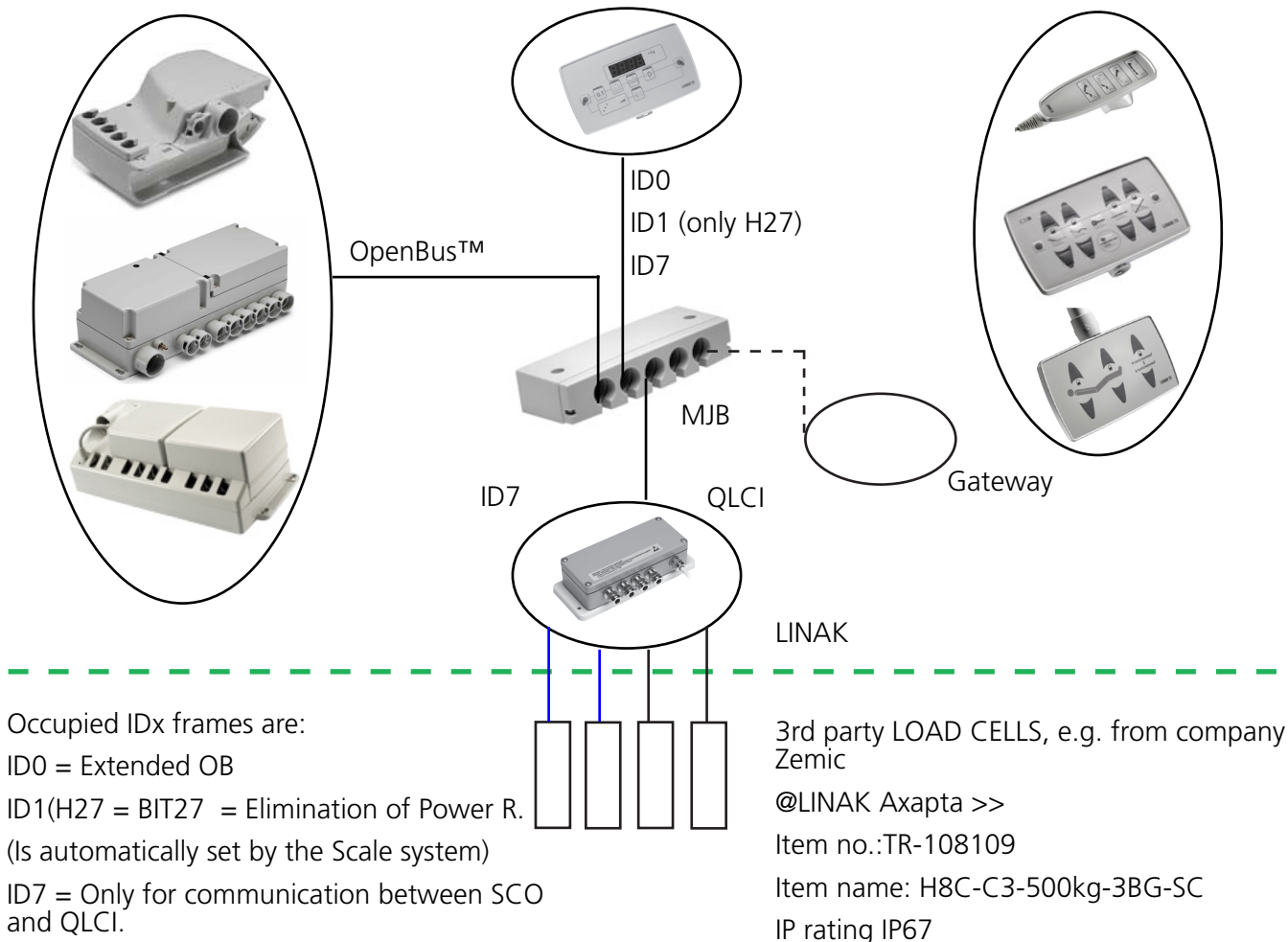

### Information

The Scale system occupies certain frames (IDx) in the OpenBus™ frame setup. Normally these do not interfere with bits used in conventional standard or special OpenBus™ application software (HB and ACx addressing are placed in ID1 and ID2).

See the Illustration above. Therefore, take care to avoid conflicts with H27 when specifying hand controls/ attendant controls.

### Using scale systems

Weighing systems are subject to important legal restrictions.

As an example, the application manufacturer MUST be certified in using and calibrating weighing systems.



---

## How to install and calibrate the Scale system

Installation and calibration of Scale depends on your Windows platform and the LINAK interface box being used.

For information re. installation and calibration of Scale, please contact your local LINAK office.



## SMPS30



The SMPS30 is a very powerful Switch Mode Power Supply typically used for Treatment or Examination Couches. The SMPS30 is an eco-friendly solution due to a low standby power consumption compared to traditional transformer solutions. The universal input voltage makes the SMPS adaptable to the worldwide market irrespective of the input voltage.

### Usage

Compatibility:	LA43 IC, LA44 IC
Duty Cycle*:	10%, 2 minutes continuous use followed by 18 minutes not in use.
Operating temperature:	5 °C to +40 °C
Storage temperature:	-10 °C to +50 °C
Relative humidity:	20% to 90% – non-condensing
Atmospheric pressure:	700 to 1060 hPa
Meters above sea level:	Max. 2000 meters
Approvals:	IEC60601-1 ANSI/AAMI ES60601-1 CAN/CSA-22.2 No 60601-1

\* At 10% duty cycle, max. output power is possible at an ambient temperature of 25 °C.

### Safety concept

DC power is only on the application when needed – when the hand control is activated.

The user is part of a safety concept with light indications showing:

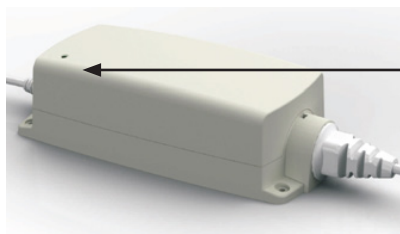

#### Connected to the mains

Green light when connected to the mains

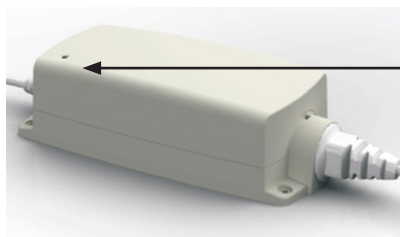

#### Power request

Yellow light at power request when the hand control is activated

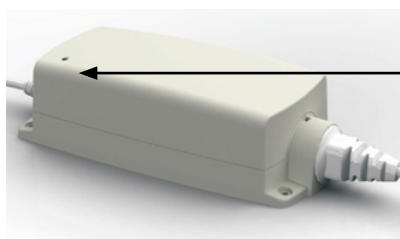

#### Check of functionality

Yellow light is turned off when releasing a hand control button – otherwise the hand control or other components in the application are defective. If so, the user must call for service.

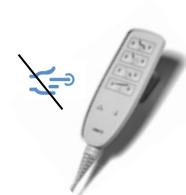

**The SMPS30 is designed for placing on the floor, but it can also be mounted on the wall / application via the bottom base plate and 4 screws.**

If the SMPS30 is mounted on the wall/application, please dismount the SMPS30 to get access to the cable locking mechanism on the mains cable.



## Recommendations

### Please note

The SMPS30 is only compatible with the LA43 IC and the LA44 IC.  
The SMPS30 is not suitable for outdoor applications.

### Before installation, re-installation or troubleshooting

- Stop the application
- Switch off the power supply and pull out the mains plug
- Relieve the application of any loads, which may be released during the work

### Before start-up

- Make sure that the system has been installed as instructed in the User Manual System connection. The individual parts must be connected before the SMPS30 is
  - connected to the mains.

### During operation

- Ensure that the cables are not damaged
- Unplug the SMPS30 before moving the equipment

### Device protection

The SMPS30 contains several mechanisms to protect itself from being damaged due to excessive use.

- In case of overheating, the device will activate a thermal protection. No power output will be available until the temperature is back again within normal operating range
- In case of exceeding the current limit / failure in the actuator, the device will activate an overload protection. Immediately after the situation has been remediated, the power output will be available again.

### Hot plugging

- It is not allowed to remove or to add the output cable as long as the SMPS is powered by the mains

### Maintenance/cleaning

- The SMPS30 must be cleaned at regular intervals to remove dust and dirt and it must be inspected for mechanical damage, wear and breaks
- It is not allowed to spray directly with a high-pressure cleaner on the device
- Interconnecting cables must remain plugged in, correctly fitted with O-rings, during cleaning to prevent ingress of water
- The SMPS30 is resistant to the majority of cleaners and disinfectants used in the hospital and nursing home sector. However, the detergents must comply with the following basic requirements
  - They must not be highly alkaline or acidic (pH value 6-8)
  - They must not contain caustic agents



## WET Sheet



The WET Sheet is an OpenBus™ product and is a part of the WET Detection solution. The WET Detection solution consists of the WET Sheet, the MJB8 and a WET Sheet cable.



### Recommendations

- The WET Sheet is a wearing part which is not covered by the standard LINAK warranty. The WET Sheet warranty is valid until the product has been put into use
- The WET Sheet is not a stand-alone article and must be included as part of an application e.g. the MJB8
- The WET Detection will not detect liquid without conductivity e.g. demineralised water
- The WET Sheet is not intended for outdoor use
- The WET Sheet is not a life-supporting unit
- Mechanical pressure on the WET Sheet can destroy the thread and connectors
- It is recommended to change the WET Sheet cable after 500 connections
- The sheet and connector must be placed properly to minimise the risk of bedsores
- The WET Sheet connector is not to be exposed to direct moisture etc. urine or sweat. Place the connector away from the user, for instance on the side of the bed and downwards.
- To ensure the right WET Detection functionality do not use layers on top of the WET Sheet, e.g. a turning sheet
- The recommended temperature for washing is 60 °C. Washing at 85 °C is acceptable, however, this will reduce the lifetime
- Tumble drying at medium heat, however, line drying is recommended
- The typical number of washing cycles is up to 50, but will depend on the washing conditions
- The WET Sheet should be washed before use and must be completely dry before it is connected.



# Contacts

## FACTORIES

Denmark - Headquarters  
LINAK A/S  
Phone: +45 73 15 15 15  
Fax: +45 74 45 80 48  
Fax (Sales): +45 73 15 16 13  
Web: www.linak.com

China  
LINAK (Shenzhen) Actuator Systems, Ltd.  
Phone: +86 755 8610 6656  
Phone: +86 755 8610 6990  
Web: www.linak.cn

Slovakia  
LINAK Slovakia s.r.o.  
Phone: +421 51 7563 444  
Web: www.linak.sk

Thailand  
LINAK APAC Ltd.  
Phone: +66 33 265 400  
Web: www.linak.com

USA  
LINAK U.S. Inc.  
Americas Headquarters  
Phone: +1 502 253 5595  
Fax: +1 502 253 5596  
Web: www.linak-us.com  
www.linak-latinamerica.com

## SUBSIDIARIES

Australia  
LINAK Australia Pty. Ltd  
Phone: +61 3 8796 9777  
Fax: +61 3 8796 9778  
E-mail: sales@linak.com.au  
Web: www.linak.com.au

Austria  
LINAK Zweigniederlassung - Österreich (Wien)  
Phone: +43 (1) 890 7446  
Fax: +43 (1) 890 744615  
E-mail: info@linak.de  
Web: www.linak.at - www.linak.hu

Belgium  
LINAK Actuator-Systems NV/SA (Belgium & Luxembourg)  
Phone: +32 (0)9 230 01 09  
E-mail: beinfo@linak.be  
Web: www.linak.be - www.fr.linak.be

Brazil  
LINAK Do Brasil Comércio De Atuadores Ltda.  
Phone: +55 (11) 2832 7070  
Fax: +55 (11) 2832 7060  
E-mail: info@linak.com.br  
Web: www.linak.com.br

Canada  
LINAK Canada Inc.  
Phone: +1 502 253 5595  
Fax: +1 416 255 7720  
E-mail: info@linak.ca  
Web: www.linak-us.com

Czech Republic  
LINAK C&S s.r.o.  
Phone: +42 058 174 1814  
Fax: +42 058 170 2452  
E-mail: info@linak.cz  
Web: www.linak.cz - www.linak.sk

Denmark - International  
LINAK International  
Phone: +45 73 15 15 15  
E-mail: info@linak.com  
Web: www.linak.com

Denmark - Sales  
LINAK Danmark A/S  
Phone: +45 86 80 36 11  
Fax: +45 86 82 90 51  
E-mail: linak@linak-silkeborg.dk  
Web: www.linak.dk

Finland  
LINAK OY  
Phone: +358 10 841 8700  
E-mail: linak@linak.fi  
Web: www.linak.fi

France  
LINAK France E.U.R.L  
Phone: +33 (0) 2 41 36 34 34  
Fax: +33 (0) 2 41 36 35 00  
E-mail: linak@linak.fr  
Web: www.linak.fr

Germany  
LINAK GmbH  
Phone: +49 6043 9655 0  
Fax: +49 6043 9655 60  
E-mail: info@linak.de  
Web: www.linak.de

India  
LINAK A/S India Liaison Office  
Phone: +91 120 4531797  
Fax: +91 120 4786428  
E-mail: info@linak.in  
Web: www.linak.in

Ireland  
LINAK UK Limited (Ireland)  
Phone: +44 (0)121 544 2211  
Fax: +44 (0)121 544 2552  
+44 (0)796 855 1606 (UK Mobile)  
+35 387 634 6554 (Rep.of Ireland Mobile)  
E-mail: sales@linak.co.uk  
Web: www.linak.co.uk

Italy  
LINAK ITALIA S.r.l.  
Phone: +39 02 48 46 33 66  
Fax: +39 02 48 46 82 52  
E-mail: info@linak.it  
Web: www.linak.it

Japan  
LINAK K.K.  
Phone: 81-45-533-0802  
Fax: 81-45-533-0803  
E-mail: linak@linak.jp  
Web: www.linak.jp

Malaysia  
LINAK Actuators Sdn. Bhd.  
Phone: +60 4 210 6500  
Fax: +60 4 226 8901  
E-mail: info@linak-asia.com  
Web: www.linak.my

Netherlands  
LINAK Actuator-Systems B.V.  
Phone: +31 76 5 42 44 40 / +31 76 200 11 10  
E-mail: info@linak.nl  
Web: www.linak.nl

New Zealand  
LINAK New Zealand Ltd  
Phone: +64 9580 2071  
Fax: +64 9580 2072  
E-mail: nzsales@linak.com.au  
Web: www.linak.com.au

Norway  
LINAK Norge AS  
Phone: +47 32 82 90 90  
E-mail: info@linak.no  
Web: www.linak.no

Poland  
LINAK Polska  
LINAK Danmark A/S (Spółka Akcyjna)  
Phone: +48 22 295 09 70 / +48 22 295 09 71  
E-mail: info@linak.pl  
Web: www.linak.pl

Republic of Korea  
LINAK Korea Ltd.  
Phone: +82 2 6231 1515  
Fax: +82 2 6231 1516  
E-mail: info@linak.kr  
Web: www.linak.kr

Slovakia  
LINAK Slovakia S.R.O.  
Phone: +421 51 7563 444  
Web: www.linak.sk

Spain  
LINAK Actuadores, S.L.U  
Phone: +34 93 588 27 77  
Fax: +34 93 588 27 85  
E-mail: esma@linak.es  
Web: www.linak.es

Sweden  
LINAK Scandinavia AB  
Phone: +46 8 732 20 00  
Fax: +46 8 732 20 50  
E-mail: info@linak.se  
Web: www.linak.se

Switzerland  
LINAK AG  
Phone: +41 43 388 31 88  
E-mail: info@linak.ch  
Web: www.linak.ch - www.fr.linak.ch  
www.it.linak.ch

Taiwan  
LINAK (Shenzhen) Actuator systems Ltd.  
Taiwan Representative office  
Phone: +886 2 272 90068  
Fax: +886 2 272 90096  
E-mail: sales@linak.com.tw  
Web: www.linak.com.tw

Turkey  
LINAK İth. İhr. San. ve Tic. A.Ş.  
Phone: +90 312 4726338  
Fax: +90 312 4726635  
E-mail: info@linak.com.tr  
Web: www.linak.com.tr

United Kingdom  
LINAK UK Limited  
Phone: +44 (0)121 544 2211  
Fax: +44 (0)121 544 2552  
E-mail: sales@linak.co.uk  
Web: www.linak.co.uk

## DISTRIBUTORS

Argentina  
Novotec Argentina SRL  
Phone: 011-4303-8989 / 8900  
Fax: 011-4032-0184  
E-mail: info@novotecargentina.com  
Web: www.novotecargentina.com

Colombia  
MEM Ltda  
Phone: +[57] (1) 334-7666  
Fax: +[57] (1) 282-1684  
E-mail: servicioalcliente@memltda.com.co  
Web: www.mem.net.co

India  
Mechatronics Control Equipments India Pvt Ltd  
Phone: +91-44-28558484, 85  
E-mail: bala@mechatronicscontrol.com  
Web: www.mechatronicscontrol.com

Indonesia  
PT. Himalaya Everest Jaya  
Phone: +6 221 544 8956 /+6 221 544 8965  
Fax: +6 221 619 1925  
Fax (Sales): +6 221 619 4658  
E-mail: hejplastic-div@centrin.net.id  
Web: www.hej.co.id

Israel  
NetivTech LTD  
Phone: +972 55-2266-535  
Fax: +972 2-9900-560  
E-mail: info@NetivTech.com  
Web: www.netivtech.com

Singapore  
Servo Dynamics Pte Ltd  
Phone: +65 6844 0288  
Fax: +65 6844 0070  
E-mail: servodynamics@servo.com.sg

South Africa  
Industrial Specialised Applications CC  
Phone: +27 011 466 0346  
E-mail: gartht@isagroup.co.za  
Web: www.isaza.co.za

United Arab Emirates  
Mechatronics  
Phone: +971 4 267 4311  
Fax: +971 4 267 4312  
E-mail: mechtron@emirates.net.ae

## Terms of Use

LINAK® takes great care to provide accurate and up-to-date information about its products. However, it is the responsibility of the user to determine the suitability of LINAK products for any specific application. Due to ongoing product development, LINAK products are subject to continuous modifications and changes. LINAK reserves the right to make such modifications, updates, and changes without prior notice. For this reason, LINAK cannot guarantee the accuracy or current status of printed information about its products.

LINAK makes every effort to fulfil orders. However, due to the factors described above, LINAK cannot guarantee the availability of any particular product at any given time. LINAK also reserves the right to discontinue the sale of any product displayed on its website, in catalogues, or in other written materials issued by LINAK or its affiliated companies. All sales are subject to the applicable terms and conditions of sale and delivery available on LINAK websites. LINAK and the LINAK logotype are registered trademarks of LINAK A/S. All rights reserved.