

Modbus TCP/IP
User Manual



Contents

Preface	3
Terms of use	4
Revision overview.....	5
Connection diagram	6
Applicable for: LA14, LA25, LA21, LA33, LA36, LA37, LA73, LA76 and LA77	6
Applicable for: LC3 IC.....	7
I/O specifications.....	8
Protection.....	9
Current limit.....	9
Parallel.....	9
Getting started	11
Power supply.....	11
Configuration	12
Parameters to be verified by Actuator Connect™	13
Command examples	14
General run prerequisites.....	14
Run the actuator outwards	15
Run the actuator to target position (150 mm).....	16
Overcurrent state.....	16
Clear error	17
Holding registers.....	18
Command.....	18
Feedback.....	19
Feedback (Parallel feedback).....	21
Parameters.....	22
Configuration.....	22
Diagnostics.....	23
Reason for Last Stop definition.....	26
Error codes	27
Parallel error codes.....	29

Preface

Dear User,

We are delighted that you have chosen a LINAK® product.

LINAK systems are high-tech products based on many years of experience in the manufacture and development of actuators, lifting columns, desk frames, electric control boxes, controls, batteries, accessories and chargers.

This User Manual does not address the end user. It is intended as a source of information for the equipment or system manufacturer only, and it will tell you how to install, use and maintain your LINAK electronics. The manufacturer of the end product has the responsibility to provide a User Manual, where relevant safety information from this manual is passed on to the end user.

We are convinced that your LINAK product/system will give you many years of problem-free operation.

Before our products leave the factory, they undergo both function and quality testing. Should you, nevertheless, experience problems with your product/system, you are always welcome to contact your supplier.

LINAK subsidiaries and some distributors situated all over the world have authorised service centres, which are always ready to help you. Locate your local contact information on the back page.

LINAK provides a warranty on all products. (See warranty section).

This warranty, however, is subject to correct use in accordance with the specifications, maintenance being done correctly, and any repairs being carried out at a service centre, which is authorised to repair LINAK products.

Changes in installation and use of LINAK systems can affect their operation and durability. The products may only be opened by authorised personnel.

This User Manual has been written based on the present technical knowledge. LINAK reserves the right to carry out technical modifications and keeps the associated information updated.

LINAK A/S

Terms of use

LINAK® takes great care in providing accurate and up-to-date information on its products. However, the user is responsible for determining the suitability of LINAK products for a specific application.

Due to continual development, LINAK products are subject to frequent modifications and changes. LINAK reserves the rights to conduct modifications, updates, and changes without any prior notice. For the same reason, LINAK cannot guarantee the correctness and actual status of imprinted information on its products.

LINAK uses its best efforts to fulfil orders. However, for the reasons mentioned above, LINAK cannot guarantee availability of any particular product at any given time. LINAK reserves the right to discontinue the sale of any product displayed on its website or listed in its catalogues or in other written material created and produced by LINAK, LINAK subsidiaries, or LINAK affiliates.

All sales are subject to the 'Standard Terms of Sale and Delivery for LINAK A/S' available on LINAK websites.

LINAK and the LINAK logotype are registered trademarks of LINAK A/S. All rights reserved.

Revision overview

Edition E

Connection diagram for linear actuators updated	Page 6
Connection diagram for LC3 IC updated	Page 7
I/O specifications updated	Page 8
Voltages removed from illustrations	Page 10
'Clear error' table added	Page 17
'Holding registers' section updated	Page 18-21
'Parameters' section updated	Page 22-25
'Reason for Last Stop definition' table added	Page 26
Parallel error code 25 - Position lost description updated	Page 30
'Slave' changed to 'Follower'	All over the document

Edition D

LA14, LA25, LA21 and LA73 added	
Plug type added to plug view	Page 6
Cable kit item numbers added	Page 6-7
'Current limit' section added	Page 9
Parallel 'Check power supply' updated	Page 9
LA14, LA25, LA21 and LA73 added to 'Configuration' section	Page 12
Register in 'General run prerequisites' updated	Page 14
Register in 'Run the actuator outwards' updated	Page 15
Register in 'Run the actuator to target position (150 mm)' updated	Page 16
'Clear error in overcurrent situation' changed to 'Overcurrent state'	Page 16
'Holding registers' updated	Page 17-22
Error codes updated	Page 23-24
Parallel error codes updated	Page 26-26
'Soft Start' changed to 'Ramp Up' + 'Soft Stop' changed to 'Ramp Down'	All over the document
Identical cells in tables merged	All over the document
'Read' and 'Write' changed to 'R' and 'W'	All over the document

Edition C

LA14 and LA25 removed	Page 6
LA33 added	Page 6
Information about separate supplies added	Page 11
Timeframe changed from 500 ms to 2,000 ms	Page 13
'Command examples' section updated	Page 13-15
'Registers' section added	Page 16-20
'Register overview' section removed	

Edition B

Item number for cable kit added	Page 6-7
'Manual run' changed to 'Extends actuator' and 'Retracts actuator'	Page 6-8
'Service interface' changed to 'Parallel data'	Page 6-8
'Service interface GND' changed to 'Parallel GND'	Page 6-8
'V DC' added	Page 6-8
Information about separate supplies added	Page 8
'Parallel' section updated	Page 10-11
Power supply table updated	Page 12
'Configuration' updated	Page 12
IP address updated	Page 13
'Run out command' changed to 'Command examples'	Page 14
'Communication sequence...' changed to 'Run the actuator outwards'	Page 14

Connection diagram

Applicable for: LA14, LA25, LA21, LA33, LA36, LA37, LA73, LA76 and LA77

BROWN 24/48 V DC

BLUE GND



4 Split power supply V DC

1 Extends the actuator

2 Retracts the actuator

3 Parallel data +

5 Parallel data -

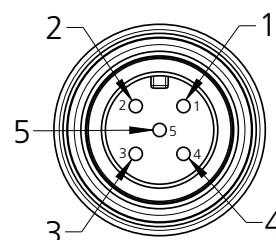

M12
A-Code male

1 ETH_TX+

2 ETH_RX+

3 ETH_TX-

4 ETH_RX-

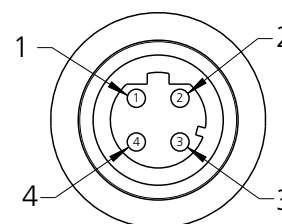

M12
D-Code female

Connection diagram

Applicable for: LC3 IC

BROWN 24/48 V DC

BLUE GND



ORANGE Split power supply V DC

RED Extends the actuator

BLACK Retracts the actuator

VIOLET Parallel data +

WHITE Parallel data -

YELLOW Not to be connected

GREEN Not to be connected

LIGHT BLUE Not to be connected

GREY Not to be connected

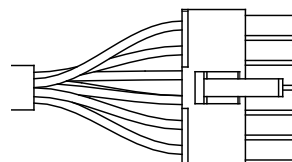

Molex mini-fit
12-pin

1 ETH_TX+

3 ETH_RX+

2 ETH_TX-

6 ETH_RX-

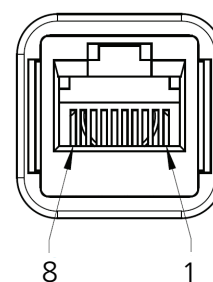

RJ45

I/O specifications

Input/Output		Specification	Comments
Description		The physical layer conforms to the IEEE 802.3-2018 standard with communication speeds of 10 Mbps and 100 Mbps, respectively. Cable length is reduced to = 100 m without repeater, as determined by IEEE 802.3-2018.	
Brown		Connect Brown to positive 24/48 V DC	Note: Do not change the power supply polarity on the Brown and Blue wires! Only for powering the motor driver module. Power supply GND is electrically connected to the housing through a capacitor and resistor in parallel.
Blue		Connect Blue to negative GND	
PIN out		Data cable M12 - 5-pin male OR Molex mini-fit - 12-pin	
M12	Molex mini-fit		
Pin 4	Orange	Split power supply V DC	Split power supply: 24 V DC with ≈ 28 mA current consumption. 48 V DC with ≈ 16 mA current consumption. The split power supply uses the common GND from the power supply (Blue). Split power supply is only for powering the communication of the integrated controller.
Pin 1	Red	Extends the actuator	The signal becomes active at: $V_{IN} > 67\%$ of V DC The signal becomes inactive at: $V_{IN} < 33\%$ of V DC Input current: 10 mA
Pin 2	Black	Retracts the actuator	
Pin 3	Violet	Parallel data +	The Parallel drive function will support up to 8 actuators running simultaneously. It is possible to run Parallel with a main power supply or separate power supplies.
Pin 5	White	Parallel data -	
PIN out		Data cable M12 - 4-pin female OR RJ45	
M12	RJ45		
Pin 1	Pin 1	ETH_TX+	
Pin 2	Pin 3	ETH_RX+	
Pin 3	Pin 2	ETH_TX-	
Pin 4	Pin 6	ETH_RX-	

Protection

Current limit

Current limits can be configured to avoid crushing when meeting an obstacle. These values can be adjusted according to your preferences. Use default values or fine-tune your current limits with 0.25 A/bit.

It is important to note that current limits should not be relied upon as a general stop function, as this will potentially stress the mechanics and could lead to long-term damage to the actuator.

Furthermore, current limits do not correlate directly with the actuator's load curves, meaning they should not be used as indicators of load. Various tolerances in components such as the spindle, nut, and gears can also affect the current consumption of the actuator. Operation in environments with temperatures below 0°C will also increase the current consumption. When temperature drops below 0°C, the default current limit will change to a higher value.

Actuator specific current limit values (above and below reference temp.) can be found in the respective actuator user manual or in the Actuator Connect service tool under 'Protection'.

Parallel

The industrial LINAK® actuators can be ordered with parallel functionality. If this feature is enabled, it is possible to run up to 8 actuators in a parallel system with just one actuator occupying an Ethernet port connection. The system works as a critical parallel, meaning that all actuators must be present in the system and have the exact same configuration (both mechanical and software functionality).

Below is a checklist to ensure that the system operates as intended:

Action	Description
Set up parallel in Actuator Connect™	Each actuator must be configured to operate in parallel (2-8 actuators). This can be set up using the Actuator Connect tool. <i>Please note: In some cases this is pre-configured from factory.</i>
Wire up the system	The actuators feature internal communication for parallel synchronisation and error codes.
Check cable lengths	Keep the total length of the communication line below 40 meters to avoid communication dropouts. In a parallel system with 8 actuators this would result in signal cable lengths of <5 metres.
Check power supply	It is also possible to use two or more separate power supplies in parallel under the condition that they have the same voltage and wattage output. It is essential that all power supplies share a common ground connection (Blue wire). Please respect actuator specifications regarding voltage level and current consumption!

Parallel

Option 1 - A simple parallel setup

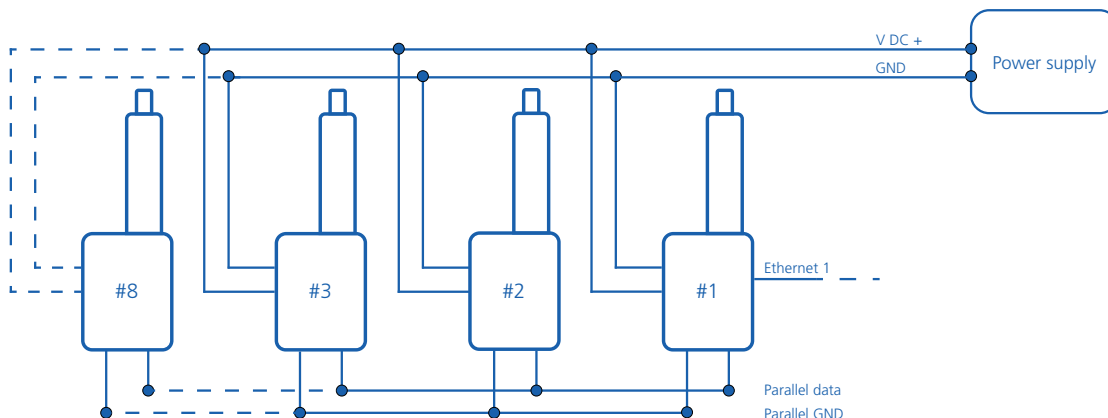

In a simple parallel setup there is only one actuator connected to the network communication. This actuator receives run commands and shares data with the controller. The remaining actuators in the system are only connected to internal parallel communication. This way, the internal communication ensures that the system operates in parallel and stops in case of an obstacle, or when other errors occur on one of the actuators.

The actuators share simple error messages with the master, which can be distributed via the network.

Option 2 - Bus communication on all actuators

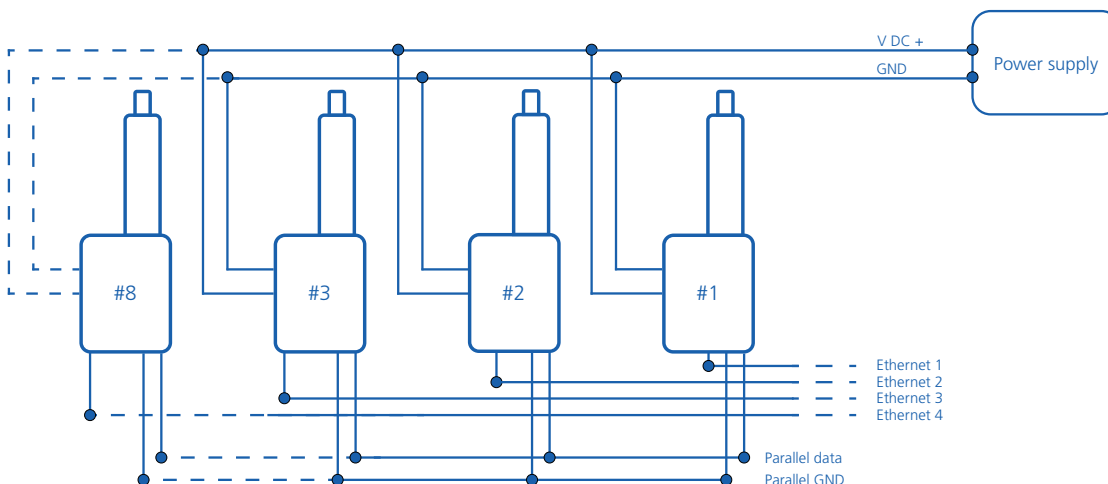

If there is a need for e.g. monitoring the real-time data of each actuator, it is possible to connect all actuators as nodes to the network. This will provide comprehensive usage data, which can be used to enhance performance in the application. Similar to option 1, this requires that all actuators are connected to internal parallel communication.

It is also possible to use two separate power supplies in parallel under the condition that they have the same voltage and wattage output. It is essential that both power supplies share a common ground connection (Blue wire).

Getting started

This section further describes how to communicate with LINAK® Modbus TCP/IP actuators and contains examples of typical user scenarios and application solutions. All examples include references to registers which are further described in detail below.

Power supply

Modbus TCP/IP actuators are available with the following supply voltage range: 24 and 48 V DC. The accepted supply voltage range is specified for the version as shown below:

Supply voltage	Function	Voltage range		
		V _{MIN}	V _{TYP}	V _{MAX}
24 V	Motor	18 V	24 V	32 V
	Modbus TCP/IP communication	10 V	24 V	39 V
48 V	Motor	36 V	48 V	58 V
	Modbus TCP/IP communication	10 V	48 V	60 V

For more information about wiring/connector, please see the connection diagram.

Configuration

Before being integrated into a Modbus system, a few of the actuator parameters must be checked and eventually changed. This preparation is done via the use of the configuration tool Actuator Connect™ and guarantees that the actuator is able to execute basic functionality.

Further fine-tuning may be required to fulfil system or application requirements. Via this tool it is also possible to access historical usage data and real-time monitoring.

Valid for LA14 and LA25:

A separate configuration cable kit (item no. 0257901 = straight Y-cable + USB2LIN) is required to use Actuator Connect™ on a PC. This cable must be connected to the 9-pin connector on the actuator side. On the opposite side, power must be applied to the flying leads, and the USB connector must be inserted into your PC.

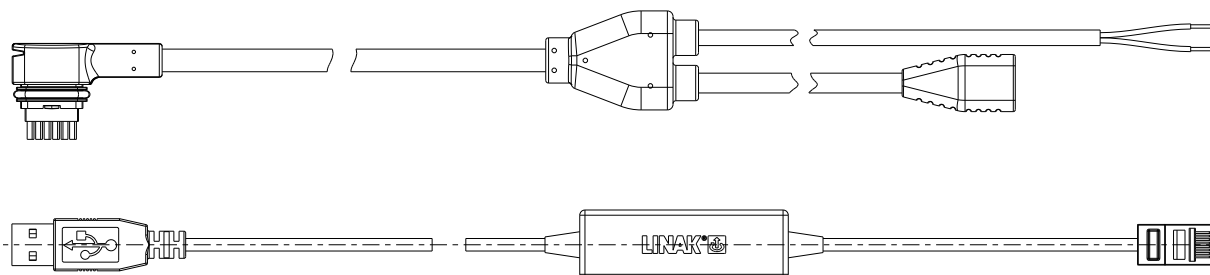

Valid for LA21, LA33, LA36, LA37, LA73, LA76, LA77 and LC3 IC:

A separate configuration cable kit (item no. 0367996 = straight Y-cable + USB2LIN) is required to use Actuator Connect™ on a PC. This cable must be connected to the 9-pin connector on the actuator side. On the opposite side, power must be applied to the flying leads, and the USB connector must be inserted into your PC.

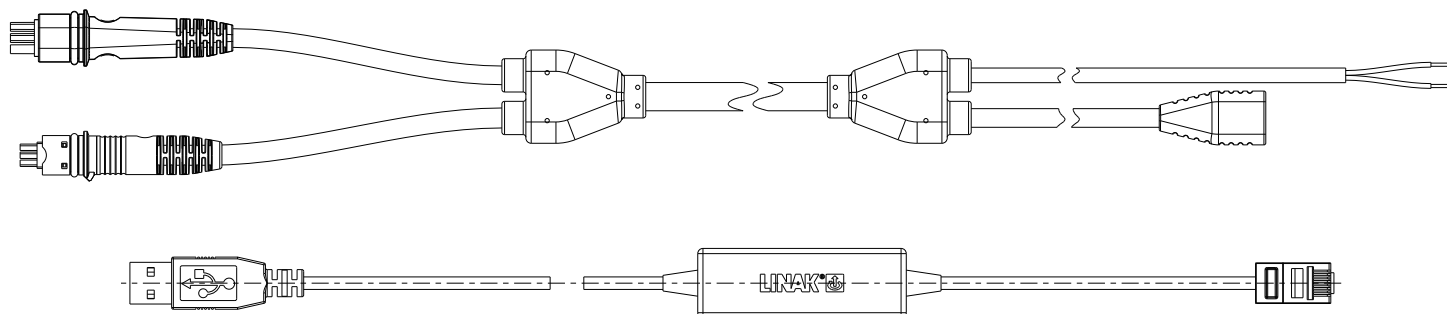

For more information about wiring/connector, please see the connection diagram.

Parameters to be verified by Actuator Connect™

Parameters	Description
DHCP	DHCP is a client/server protocol that automatically provides an IP address. If enabled: below parameters are not configurable
IP Address	Set the device IP address to a unique address in the network. 192.168.1.10 (default)
Subnet mask	Set the subnet mask. 255.255.255.0 (default)
Gateway	Set the gateway. 192.168.1.1 (default)

The full Application Data Unit (ADU) used by the Modbus TCP/IP protocol is encapsulated within the data segment of a conventional TCP packet. This packet is then transmitted over the network to the designated system port number 502, a port which is exclusively allocated for Modbus application communications.



Users are strongly advised against configuring their assets directly to the public internet. By taking this precautionary measure, the risk of unauthorized and malicious cyber activities from external threats is significantly reduced.

Command examples

Before the actuator can engage movement, some general prerequisites must be fulfilled. Timing (e.g. when the actuator is still moving), environmental conditions and errors may indicate that the actuator is in a state where further operation is not possible.

General run prerequisites

Step	Read/Write	Register	Action
1	W	Command [0x2001] Index 0	“Communication heartbeat counter” must be incremented periodically with the value ranging from 0-255 [0x00-FF] Must be updated in periods no longer than 2,000 ms If not updated within 2,000 ms, the actuator will stop and the “Error code” register will read a value of 5 (Communication sync.)
2		Command [0x2002] Index 1	“Position” must be set to = 64259 [0x FB03] for ‘Stop’ To prevent unintended movement, it is required to send a ‘Stop’ command before running the actuator
3	R	Feedback [0x2104] Index 3	“Error code” must be = 0 [0x00]
4		Feedback [0x2103] Index 2	“Status Flags” bit 2 (Overcurrent) must be = 0
5		Feedback [0x2103] Index 2	“Status Flags” bit 5 (Heartbeat needed) must be = 0
6		Feedback [0x2103] Index 2	“Status Flags” bit 6 (Actuator is running outside nominal conditions) must be = 0

Run the actuator outwards

Step	Read/Write	Register	Action
1		-	Check that general run prerequisites are fulfilled.
2	W	Command [0x2003] Index 2	“Current” must be set to a value 0-250 [0x00-FA] = Current limit 0.25 A/bit 251 [0xFB] = Default current limit set via Actuator Connect™ 252-255 [0xFC-FF] = Reserved
3		Command [0x2004] Index 3	“Speed” must be set to a value 0-200 [0x00-FA] = Speed 0.5% /bit 201-250 [0xC9-FA] = 100% speed 251 [0xFB] = Default speed set via Actuator Connect 252-255 [0xFC-FF] = Reserved
4		Command [0x2005] Index 4	“Ramp Up” must be set to a value 0-200 [0x00-FA] = Start ramp time 0.05 s /bit 251 [0xFB] = Default speed set via Actuator Connect 252-255 [0xFC-FF] = Reserved
5		Command [0x2006] Index 5	“Ramp Down” must be set to a value 0-200 [0x00-FA] = Stop ramp time 0.05 s /bit 251 [0xFB] = Default speed set via Actuator Connect 252-255 [0xFC-FF] = Reserved
6		Command [0x2002] Index 1	“Position” must be set to = 64257 [0xFB01] for ‘Run out’
7*	R	Feedback [0x2103] Index 2	“Status Flags” bit 3 and bit 1 change to 1 to indicate that: Bit 3 = Actuator is running out Bit 1 = Endstop reached signal out

* Optional

Run the actuator to target position (150 mm)

Step	Read/Write	Register	Action
1		-	Check that general run prerequisites are fulfilled.
2	W	Command [0x2003] Index 2	“Current” must be set to a value 0-250 [0x00-FA] = Current limit 0.25 A/bit 251 [0xFB] = Default current limit set via Actuator Connect™ 252-255 [0xFC-FF] = Reserved
3		Command [0x2004] Index 3	“Speed” must be set to a value 0-200 [0x00-FA] = Speed 0.5%/bit 201-250 [0xC9-FA] = 100% speed 251 [0xFB] = Default speed set via Actuator Connect 252-255 [0xFC-FF] = Reserved
4		Command [0x2005] Index 4	“Ramp Up” must be set to a value 0-200 [0x00-FA] = Start ramp time 0.05 s/bit 251 [0xFB] = Default speed set via Actuator Connect 252-255 [0xFC-FF] = Reserved
5		Command [0x2006] Index 5	“Ramp Down” must be set to a value 0-200 [0x00-FA] = Stop ramp time 0.05 s/bit 251 [0xFB] = Default speed set via Actuator Connect 252-255 [0xFC-FF] = Reserved
6		Command [0x2002] Index 1	“Position” must be set to = 1500 [0x05DC] for ‘Run to Target Position 150 mm’
7*	R	Feedback [0x2103] Index 2	“Status Flags” bit 3 or bit 4 change to 1 to indicate that either: Bit 3 = Actuator is running out Bit 4 = Actuator is running in

Overcurrent state

If an overcurrent occurs, the actuator will be stopped and blocked in that direction until an activation in the opposite direction has been made or the system has been re-powered.

Step	Read/Write	Register	Action
1	R	Feedback [0x2103] Index 2	Confirm that “Status Flags” bit 2 is = 1 for ‘Overcurrent’
2	W	Command [0x2003] Index 2	“Position” must be set to run in the opposite direction of the blockage Set to = 64257 [0xFB01] for ‘Run out’ or Set to = 64258 [0xFB02] for ‘Run in’
3*	R	Feedback [0x2103] Index 2	“Status Flags” bits change to 1 to indicate that either: Bit 3 = Actuator is running out Bit 4 = Actuator is running in Bit 1 = Endstop reached out Bit 0 = Endstop reached in

* Optional

Clear error

If an error occurs, the actuator will be stopped, and normal movement will not be possible.

Step	Read/Write	Holding Registers	Action
1	R	Feedback Index 3	Confirm that "Error Code" is not = 0
2	W	Command Index 1	"Position" set to = 64256 (Clear Error Codes)
3	R	Feedback Index 3	Confirm that "Error Code" is = 0 If "Error Code" is not = 0, then correct the error in the system and repeat step 2.

Holding registers

When controlling the actuator from the Modbus controller, it is important to understand the input and output data. The specific data is described in the tables below.

Command

To write a single parameter register use function code FC6 (Write Single Holding Register).

To write multiple parameter registers use function code FC16 (Write Multiple Holding Registers).

Command Holding registers					
0x2006	0x2005	0x2004	0x2003	0x2002	0x2001
Ramp Down	Ramp Up	Speed	Current Limit	Position	Heartbeat counter

Command Holding registers					
Address	Command	Data type	Details	Description	Scaling
0x2001	Heartbeat counter*	UINT8	0-255	Communication heartbeat counter	
0x2002	Position	UINT16	0-64255	Run to position	0.1 mm/bit
			64256	Clear error code (See Feedback 0x2104)	
			64257	Run out	
			64258	Run in	
			64259	Stop	
			64260	Recovery run out	
			64261	Recovery run in	
			64262-65535	Invalid value. Actuator will not run.	
0x2003	Current Limit	UINT8	0-250	Maximum current limit	0.25 A /bit
			251	Default current limit	
			252-255	Invalid value. Actuator will not run.	
0x2004	Speed	UINT8	0-200	Speed	0.5% /bit
			201-250	100% speed	
			251	Default speed	
			252-255	Invalid value. Actuator will not run.	
0x2005	Ramp Up	UINT8	0-250	Ramp up time	0.05 s/bit
			251	Default ramp up time	
			252-255	Invalid value. Actuator will not run.	
0x2006	Ramp Down	UINT8	0-250	Ramp down time	0.05 s/bit
			251	Default ramp down time	
			252-255	Invalid value. Actuator will not run.	

* Must be incremented in periods no longer than 2,000 ms with a value ranging from 0-255. Without regular updates, actuator will stop.

Feedback

To read single or multiple parameter register(s) use function code FC03 (Read Multiple Holding Register).

Feedback Holding Registers					
0x2106	0x2105	0x2104	0x2103	0x2102	0x2101
AUX Inputs	Speed	Error Code	Status Flags	Current Draw	Position

Feedback Holding Registers					
Address	Command	Data type	Details	Description	Scaling
0x2101	Position	UINT16	0–64255	Position of the actuator	0.1 mm /bit
			64256– 65023	Reserved	
			65024	Position lost	
			65025– 65535	Reserved	
0x2102	Current Draw	UINT8	0	Not running	0.25 A /bit
			1–250	Measured current draw	
			251–253	Reserved	
			254	Fault in current measurement circuit	
			255	Reserved	
0x2103	Status Flags	UINT8	b0	Endstop reached in	Bit-independent status indicators
			b1	Endstop reached out	
			b2	Overcurrent	
			b3	Running out	
			b4	Running in	
			b5	Communication heartbeat needed	
			b6	Actuator is running outside nominal conditions	
			b7	Reserved	
			b8-b15	Reserved	

Feedback

Address	Command	Data type	Details	Description	Scaling
0x2104	Error Code*	UINT8	0	No error detected	8-bit error code showing the currently active error with the highest priority only
			1	Power on block state	
			2	Position sensor	
			3	Overvoltage	
			4	Undervoltage	
			5	Communication sync.	
			6	Endstop switch	
			7	Temperature	
			8	Motor controller	
			9	Internal power supply	
			10	Internal current measurement	
			11	Parallel arbitration	
			12	Position not changing	
			13	Position initialisation not possible	
			14	Alone in parallel system	
			15	Incorrect number in parallel system	
			16	Hardware	
			17	BLDC motor	
			18	Parallel communication	
			19	Parallel running	
			20	Parallel setup stopped	
				254	
	255	Other external error (Not specified)			
0x2105	Speed	UINT16	0–4015	Speed of actuator	0.1 mm/s /bit
			4016–65535	Reserved	
0x2106	AUX Inputs	UINT8	b0–b1	Input 1 level	1 bit / 25% VCC _{IN}
			b2–b3	Input 2 level	
			b4–b5	Reserved	

* See Error code descriptions in section: [Error codes](#)

Feedback (Parallel feedback)

To read single or multiple parameter register(s) use function code FC03 (Read Multiple Holding Register).

Some parameters are split into two registers; to read them, both registers must be accessed and concatenated. In a big-endian system, the register with the lowest index value, which corresponds to the lowest memory address, is always the Most Significant Word (MSW).

Parallel feedback Holding Registers		
0x210A	0x2109	0x2107-2108
Parallel Status Flags	Parallel Error Code	Parallel Error Source

Address	Command	Data type	Details	Description	Scaling
0x2107-2108	Parallel Error Source	UINT32	0	No error detected.	
			1 - 4.294.967.295	IP address of actuator with the highest priority error.	Decimal to IPv4
0x2109	Parallel Error Code*	UINT8	0	No error detected	8-bit error code showing the currently active error with the highest priority only
			1	Current overload	
			2	Hardware	
			3	Temperature	
			4	Overvoltage	
			5	Undervoltage	
			6	Analogue input out of range error	
			7	Position not changing	
			8	Power on block state	
			9	Position initialisation not possible	
			10	Parallel start-up	
			11	Parallel running	
			12	BLDC motor	
			13	Endstop switch	
			14	Parallel communication	
			15	Parallel setup stopped	
0x210A	Parallel Status Flags	UINT8	b0	Parallel endstop reached out	Bit-independent status indicators
			b1	Parallel endstop reached in	
			b2	Parallel running outside nominal conditions	
			b3-b15	Reserved. Always high	

* See Parallel error code descriptions in section: [Parallel error codes](#)

Parameters

Used for reading and writing actuator specific parameters.

To read single or multiple parameter register(s) use function code FC03 (Read Multiple Holding Register).

To write single parameter register use function code FC6 (Write Single Holding Register).

To write multiple parameter registers use function code FC16 (Write Multiple Holding Registers).

Some parameters are split into two registers; to read them, both registers must be accessed and concatenated. In a big-endian system, the register with the lowest index value, which corresponds to the lowest memory address, is always the Most Significant Word (MSW).

Configuration

Configuration Holding Registers						
Address	Parameter	Data type	Details	Description	Scaling	Access
0x4001	Current Limit - Outwards	UINT8	0-255	Works only when PDO "Current Limit" is 251*	0.25 A/bit	R/W
0x4002	Current Limit - Inwards					
0x4003	Ramp Up - Outwards	UINT16	0-65535	Works only when PDO "Ramp Up" is 251	1 ms/bit	R/W
0x4004	Ramp Up - Inwards					
0x4005	Ramp Down - Outwards			Works only when PDO "Ramp Down" is 251		
0x4006	Ramp Down - Inwards					
0x4007	Maximum Speed	UINT8	0-200	Overrules PDO "Speed"	0.5% /bit	R/W
			201-255		100%	
0x4008	Virtual Endstop - Outwards	UINT16	0	Sets the Virtual Endstop Outwards position	Disabled	R/W
			1-699		Do NOT set below 70 mm**	
			700-65535		0.1 mm/bit	
0x4009	Virtual Endstop - Inwards	UINT16	0	Sets the Virtual Endstop Inwards position	Disabled	R/W
			1-350		0.1 mm/bit	
			351-65535		Do NOT set above 35 mm**	

* Actuator must power cycle before changes apply.

** Virtual limits set in the Initialisation zone will make initialisation impossible.

Diagnostics

Configuration Holding Registers						
Address	Parameter	Data type	Details	Description	Scaling	Access
0x400A-400B	UIN	UINT32		Unique 8-digit identification number		R
Software						
0x400C-400D	Variant	UINT32		SWxxxxxxxxVx-x		R
0x400E-400F	Version Major			SWxxxxxxxxVx-x		
0x4010-40011	Version Minor			SWxxxxxxxxVx-x		
0x4012-4013	Config. Production Order No.	UINT32		Unique 8-digit identification number		R
0x4014-4015	Production Date			yyyymmdd		
0x4016	Max. Current Seen	UINT8		0.25 A/bit		R
0x4017	Max. FET Temperature Seen			1°C /bit - 40°C		
0x4018	Max. Ambient Temperature Seen					
0x4019	Min. Ambient Temperature Seen					
0x401A-401B	Total Current Usage	UINT32		1 (Ampere*seconds)/bit		R
0x401C-401D	Total Runtime			1 s/bit		
Number of stops due to						
0x401E	Overtoltage	UINT8		Number of stops		R
0x401F	FET Overtemperature					
0x4020	Ambient Overtemperature					
0x4021	Undervoltage					
0x4022	Hall Error					
0x4023	Endstop Switch Error					
0x4024	Default Current Limit Overload - Out					
0x4025	Default Current Limit Overload - In					

Diagnosics

Configuration Holding Registers						
Address	Parameter	Data type	Details	Description	Scaling	Access
Number of resettable stops due to						
0x4026	Custom Current Limit Overload - Out	UINT8		Can be used to keep track of current overload stops from the last reset. Can only be set to 0.		R/W
0x4027	Custom Current Limit Overload - In					
Number of						
0x4028	Communication Errors	UINT16		Number of		R
0x4029-402A	Endstops Reached - Out	UINT32				
0x402B-402C	Endstops Reached - In					
0x402D-0x402E	Starts - Out					
0x402F-4030	Starts - In					
0x4031-4032	Total Piston Distance Travelled	UINT32		5 m/bit		R
Reason for last stop - ID 0: See Reason for Last Stop definitions in section below						
0x4033	Reason	UINT16		Reason for stop		R
0x4034	Count	UINT8		Number of stops in a row		
0x4035-4036	Powered Time	UINT32		Powered time when the last stop occurred		
Reason for last stop - ID 1: See Reason for Last Stop definitions in section below						
0x4037	Reason	UINT16		Reason for stop		R
0x4038	Count	UINT8		Number of stops in a row		
0x4039-403A	Powered Time	UINT32		Powered time when the last stop occurred		
Reason for last stop - ID 2: See Reason for Last Stop definitions in section below						
0x403B	Reason	UINT16		Reason for stop		R
0x403C	Count	UINT8		Number of stops in a row		
0x403D-403E	Powered Time	UINT32		Powered time when the last stop occurred		
Reason for last stop - ID 3: See Reason for Last Stop definitions in section below						
0x403F	Reason	UINT16		Reason for stop		R
0x4040	Count	UINT8		Number of stops in a row		
0x4041-4042	Powered Time	UINT32		Powered time when the last stop occurred		

Diagnostics

Configuration Holding Registers						
Address	Parameter	Data type	Details	Description	Scaling	Access
Reason for last stop - ID 4: See Reason for Last Stop definitions in section below						
0x4043	Reason	UINT16		Reason for stop		R
0x4044	Count	UINT8		Number of stops in a row		
0x4045-4046	Powered Time	UINT32		Powered time when the last stop occurred	1 s/bit	
IP address in parallel system						
0x4047-4048	Total Corrected Distance	UINT32		1 mm/bit		R
0x4049	FET Temperature	UINT8		1°C /bit - 40°C		
0x404A	Ambient Temperature					
0x404B	Number of Hall Shifts at Learn	UINT16		0.1 mm/bit		
0x404D	Zero Point Offset at Learn					
0x404F-4050	Production Order Number	UINT32		Unique 8-digit identification number		
LINAK special functions						
0x4051	Functions	UINT8	0	Reserved		R/W
			1	Restart actuator		
			2-255	Reserved		
IP address in parallel system						
0x4052-4053	Address 1	UINT32		Sorted in descending order		R
0x4054-4055	Address 2					
0x4056-4057	Address 3					
0x4058-4059	Address 4					
0x405A-405B	Address 5					
0x405C-405D	Address 6					
0x405E-405F	Address 7					
0x4060-4061	Address 8					
IP address in parallel system						
0x4062-4063	Powered Time	UINT32		1 s/bit		R
0x4064	Remaining Life	UINT8	0-100	Remaining life (Counting down)	1% /bit	
			101-249	Reserved		
			250	Remaining life not supported		
			251-255	Reserved		

Reason for Last Stop definition

Reason for Last Stop	Function	Description
1	H-bridge fault	There is a hardware problem causing the system to malfunction or the gate driver to not respond correctly.
2	Overtemperature	The device or the surrounding temperature got too hot while it was running.
4	Undervoltage	The voltage dropped below the required level while it was running.
8	Overcurrent	Current consumption exceeded the limit, resulting in a time-out or an actuator stall.
16	SMPS fault	The 12 V and/or 5 V levels are not within the normal range.
32	EOS fault	Both EOS switches were turned on at the same time while running.
64	Hall fault	One Hall sensor changed more than 10 times while the motor voltage was high, but the other sensor did not change.
256	Overvoltage	The voltage went too high while it was running, probably because of the braking.
512	Position not changing	Even though power is above the level needed for the motor to turn, the position doesn't change.
1024	HW fault	A hardware problem has occurred. Possible reasons include issues with gate driver, incorrect current measurements, or a malfunctioning motor sensor.
2048	Communication drop-out	The source of the request stopped or the signal was lost.
4096	Change of interface	The actuator is connected to a more important system than the one that made the request.
4097	Parallel master detected a change in the number of connected followers	The parallel system stopped because a registered device disconnected, or a new device connected.
4098	Parallel master was stopped by follower	A parallel master stopped running because a follower requested the master to hard stop.
4099	Parallel follower lost connection to master	A parallel follower stopped running because the connection to the master was lost.
4100	Parallel communication fault	An actuator in the parallel system stopped working because it had too many communication errors in a short time.

Error codes

All error codes apply to the entire TECHLINE® interface portfolio; some may not relate to your specific interface or product type.

Error	Description
0	No error detected No LINAK defined error detected.
1	Power on block state As a safety precaution to prevent unintentional movement at power-up, the actuator will not run until a 'Stop' command or 'Clear error' command has been sent.
2	Position sensor Position sensors are outside of expected operating range. Example: 10 pulses were reported on one Hall sensor and no Hall pulses on the other. Send 'Clear error' command to clear error. If the error persists, contact LINAK or replace the product.
3	Overvoltage Input supply voltage is above operating voltage level. Consult the documentation for correct voltage levels. The error will automatically be cleared when voltage is within operating limits.
4	Undervoltage Input supply voltage is below operating voltage level. The error can only be cleared by sending a 'Clear error' command once the voltage is within the acceptable range. Consult the documentation for correct voltage levels.
5	Communication sync. Heartbeat from the master is not within the expected heartbeat interval. Consult the documentation for minimum requirements for heartbeat interval.
6	Endstop switch Endstop switches are behaving unexpectedly. Example: Both endstop switches have been activated simultaneously for more than 100 ms. Perform the initialisation process by running the actuator fully extended and retracted.
7	Temperature Internal actuator temperature is above operating limit. Consult the documentation for correct temperature levels. The error will automatically be cleared when the temperature is within operating limits.
8	Internal motor controller Internal motor controller hardware error. Send 'Clear error' command to clear error. If the error persists, contact LINAK or replace the product.
9	Internal power supply The internal power supply is behaving unexpectedly. Send 'Clear error' command to clear error. If the error persists, contact LINAK or replace the product.
10	Internal current measurement Internal current reference is outside the expected limits. Send 'Clear error' command to clear error. If the error persists, contact LINAK or replace the product.
11	Parallel arbitration Start-up parallel configuration procedure in progress.

Error codes

Error	Description
12	Position not changing Internal position sensor is behaving unexpectedly and motor might stall. Please check your application for blockage or other irregularities. If the error persists, contact LINAK or replace the product.
13	Position initialisation not possible Internal initialisation parameters missing. Contact LINAK.
14	Alone in parallel system Incorrect number of actuators in parallel system.
15	Incorrect number in parallel system Incorrect number of actuators in parallel system or wrongly configured.
16	Hardware There is an internal motor controller malfunction affecting the actuator's ability to operate correctly. Contact LINAK.
17	BLDC motor Position sensors are outside of expected operating range. Example: 10 pulses were reported on one Hall sensor and no Hall pulses on the other. Send 'Clear error' command to clear error. If the error persists, contact LINAK or replace the product.
18	Parallel communication There are issues with the communication setup among the master and the follower devices. Make sure all cables are secured properly in the connectors.
19	Parallel running Parallel out of sync.
20	Parallel setup stopped The parallel master was stopped by a follower with some fault. To diagnose the specific issue, refer to the separate parallel feedback where the error codes from the followers can be read for more detailed information.
254	Other internal error (Not specified) Unspecified internal hardware/software error. Send 'Clear error' command to clear error. If the error persists, contact LINAK or replace the product.
255	Other external error (Not specified) Unspecified external hardware/software error. Please inspect your application for possible issues. Send 'Clear error' command to clear error.

Parallel error codes

All error codes apply to the entire TECHLINE® interface portfolio; some may not relate to your specific interface or product type.

Error	Description
0	No error detected No LINAK defined error detected.
1	Current overload Current draw is above allowed operating limit. Reduce load, send a 'Clear error' command, and run the actuator in the opposite direction.
2	Hardware Internal hardware error. Send 'Clear error' command to clear error. If the error persists, contact LINAK or replace the product.
3	Temperature Internal actuator temperature is above operating limit. Consult the documentation for correct temperature levels. The error will automatically be cleared when the temperature is within operating limits.
4	Oversvoltage Input supply voltage is above operating voltage level. Consult the documentation for correct voltage levels. The error will automatically be cleared when voltage is within operating limits.
5	Undersvoltage Input supply voltage is below operating voltage level. Consult the documentation for correct voltage levels. The error will automatically be cleared when voltage is within operating limits.
6	Analogue input out of range Analogue input signal is outside operating limits. Servo or Proportional. Consult the documentation for correct input signal.
7	Position not changing Internal position sensor is behaving unexpectedly and motor might stall. Please check your application for blockage or other irregularities. If the error persists, contact LINAK or replace the product.
8	Power on block state Communication has been overruled by a higher priority input. Communication is split into the following priorities: <ol style="list-style-type: none"> 1. Bus communication (CAN bus, EtherNet/IP, etc.) 2. LINAK service tool (Actuator Connect™) 3. Manual run using Red and Black wires Send a 'Clear error' command to continue.
9	Position initialisation not possible Internal initialisation parameters missing. Contact LINAK.
10	Parallel start-up Error in parallel setup. The number of connected actuators does not match your configuration. Check the configuration by using the LINAK tool Actuator Connect.
11	Parallel running The actuators are performing the internal setup and are not ready for operation.

Parallel error codes

Error	Description
12	<p>BLDC motor</p> <p>Internal hardware error. Send 'Clear error' command to clear error. If the error persists, contact LINAK or replace the product.</p>
13	<p>Endstop switch</p> <p>Endstop switches are behaving unexpectedly. Both endstop switches have been activated simultaneously for more than 100 ms. Perform the initialisation process by running the actuator fully extended and retracted.</p>
14	<p>Parallel communication</p> <p>Error in internal parallel communication. More than 5 communication errors in 500 ms. Please check the wire connections and re-power the complete setup.</p>
15	<p>Parallel setup stopped</p> <p>One or more actuators cannot comply with commands and stop. Master commands 'Stop' to other actuators in the network. Send 'Clear error' command to clear error. If the error persists, check your application and wire connections and re-power your complete setup.</p>
24	<p>Other error</p> <p>Actuator receives an undefined error code. This can be due to outdated firmware. Send 'Clear error' command to clear error. If the error persists, contact LINAK or replace the product.</p>
25	<p>Position lost</p> <p>The actuator has lost track of its position. Please run the actuator completely inwards and run outwards past the area from 35-70 mm to initialise the actuator.</p>

Contacts

FACTORIES

Denmark - Headquarters
LINAK A/S
Phone: +45 73 15 15 15
Fax: +45 74 45 80 48
Fax (Sales): +45 73 15 16 13
Web: www.linak.com

China
LINAK (Shenzhen) Actuator Systems, Ltd.
Phone: +86 755 8610 6656
Phone: +86 755 8610 6990
Web: www.linak.cn

Slovakia
LINAK Slovakia s.r.o.
Phone: +421 51 7563 444
Web: www.linak.sk

Thailand
LINAK APAC Ltd.
Phone: +66 33 265 400
Web: www.linak.com

USA
LINAK U.S. Inc.
Americas Headquarters
Phone: +1 502 253 5595
Fax: +1 502 253 5596
Web: www.linak-us.com
www.linak-latinamerica.com

SUBSIDIARIES

Australia
LINAK Australia Pty. Ltd
Phone: +61 3 8796 9777
Fax: +61 3 8796 9778
E-mail: sales@linak.com.au
Web: www.linak.com.au

Austria
LINAK Zweigniederlassung - Österreich (Wien)
Phone: +43 (1) 890 7446
Fax: +43 (1) 890 744615
E-mail: info@linak.de
Web: www.linak.at - www.linak.hu

Belgium
LINAK Actuator-Systems NV/SA
(Belgium & Luxembourg)
Phone: +32 (0)9 230 01 09
E-mail: beinfo@linak.be
Web: www.linak.be - www.fr.linak.be

Brazil
LINAK Do Brasil Comércio De Atuadores Ltda.
Phone: +55 (11) 2832 7070
Fax: +55 (11) 2832 7060
E-mail: info@linak.com.br
Web: www.linak.com.br

Canada
LINAK Canada Inc.
Phone: +1 502 253 5595
Fax: +1 416 255 7720
E-mail: info@linak.ca
Web: www.linak-us.com

Czech Republic
LINAK C&S s.r.o.
Phone: +42 058 174 1814
Fax: +42 058 170 2452
E-mail: info@linak.cz
Web: www.linak.cz - www.linak.sk

Denmark - International
LINAK International
Phone: +45 73 15 15 15
E-mail: info@linak.com
Web: www.linak.com

Denmark - Sales
LINAK Danmark A/S
Phone: +45 86 80 36 11
Fax: +45 86 82 90 51
E-mail: linak@linak-silkeborg.dk
Web: www.linak.dk

Finland
LINAK OY
Phone: +358 10 841 8700
E-mail: linak@linak.fi
Web: www.linak.fi

France
LINAK France E.U.R.L
Phone: +33 (0) 2 41 36 34 34
Fax: +33 (0) 2 41 36 35 00
E-mail: linak@linak.fr
Web: www.linak.fr

Germany
LINAK GmbH
Phone: +49 6043 9655 0
Fax: +49 6043 9655 60
E-mail: info@linak.de
Web: www.linak.de

India
LINAK A/S India Liaison Office
Phone: +91 120 4531797
Fax: +91 120 4786428
E-mail: info@linak.in
Web: www.linak.in

Ireland
LINAK UK Limited (Ireland)
Phone: +44 (0)121 544 2211
Fax: +44 (0)121 544 2552
+44 (0)796 855 1606 (UK Mobile)
+35 387 634 6554 (Rep.of Ireland Mobile)
E-mail: sales@linak.co.uk
Web: www.linak.co.uk

Italy
LINAK ITALIA S.r.l.
Phone: +39 02 48 46 33 66
Fax: +39 02 48 46 82 52
E-mail: info@linak.it
Web: www.linak.it

Japan
LINAK K.K.
Phone: 81-45-533-0802
Fax: 81-45-533-0803
E-mail: linak@linak.jp
Web: www.linak.jp

Malaysia
LINAK Actuators Sdn. Bhd.
Phone: +60 4 210 6500
Fax: +60 4 226 8901
E-mail: info@linak-asia.com
Web: www.linak.my

Netherlands
LINAK Actuator-Systems B.V.
Phone: +31 76 5 42 44 40 /
+31 76 200 11 10
E-mail: info@linak.nl
Web: www.linak.nl

New Zealand
LINAK New Zealand Ltd
Phone: +64 9580 2071
Fax: +64 9580 2072
E-mail: nzsales@linak.com.au
Web: www.linak.com.au

Norway
LINAK Norge AS
Phone: +47 32 82 90 90
E-mail: info@linak.no
Web: www.linak.no

Poland
LINAK Polska
LINAK Danmark A/S (Spółka Akcyjna)
Phone: +48 22 295 09 70 /
+48 22 295 09 71
E-mail: info@linak.pl
Web: www.linak.pl

Republic of Korea
LINAK Korea Ltd.
Phone: +82 2 6231 1515
Fax: +82 2 6231 1516
E-mail: info@linak.kr
Web: www.linak.kr

Slovakia
LINAK Slovakia S.R.O.
Phone: +421 51 7563 444
Web: www.linak.sk

Spain
LINAK Actuadores, S.L.u
Phone: +34 93 588 27 77
Fax: +34 93 588 27 85
E-mail: esma@linak.es
Web: www.linak.es

Sweden
LINAK Scandinavia AB
Phone: +46 8 732 20 00
Fax: +46 8 732 20 50
E-mail: info@linak.se
Web: www.linak.se

Switzerland
LINAK AG
Phone: +41 43 388 31 88
E-mail: info@linak.ch
Web: www.linak.ch - www.fr.linak.ch
www.it.linak.ch

Taiwan
LINAK (Shenzhen) Actuator systems Ltd.
Taiwan Representative office
Phone: +886 2 272 90068
Fax: +886 2 272 90096
E-mail: sales@linak.com.tw
Web: www.linak.com.tw

Turkey
LINAK İth. İhr. San. ve Tic. A.Ş.
Phone: +90 312 4726338
Fax: +90 312 4726635
E-mail: info@linak.com.tr
Web: www.linak.com.tr

United Kingdom
LINAK UK Limited
Phone: +44 (0)121 544 2211
Fax: +44 (0)121 544 2552
E-mail: sales@linak.co.uk
Web: www.linak.co.uk

DISTRIBUTORS

Argentina
Novotec Argentina SRL
Phone: 011-4303-8989 / 8900
Fax: 011-4032-0184
E-mail: info@novotecargentina.com
Web: www.novotecargentina.com

Colombia
MEM Ltda
Phone: +[57] (1) 334-7666
Fax: +[57] (1) 282-1684
E-mail: servicioalcliente@memltda.com.co
Web: www.mem.net.co

India
Mechatronics Control Equipments India Pvt Ltd
Phone: +91-44-28558484, 85
E-mail: bala@mechatronicscontrol.com
Web: www.mechatronicscontrol.com

Indonesia
PT. Himalaya Everest Jaya
Phone: +6 221 544 8956 /+6 221 544 8965
Fax: +6 221 619 1925
Fax (Sales): +6 221 619 4658
E-mail: hejplastic-div@centrin.net.id
Web: www.hej.co.id

Israel
NetivTech LTD
Phone: +972 55-2266-535
Fax: +972 2-9900-560
Email: info@NetivTech.com
Web: www.netivtech.com

Singapore
Servo Dynamics Pte Ltd
Phone: +65 6844 0288
Fax: +65 6844 0070
E-mail: servodynamics@servo.com.sg

South Africa
Industrial Specialised Applications CC
Phone: +27 011 466 0346
E-mail: gartht@isagroup.co.za
Web: www.isaza.co.za

United Arab Emirates
Mechatronics
Phone: +971 4 267 4311
Fax: +971 4 267 4312
E-mail: mechtron@emirates.net.ae