

# Linear Actuator LA21

## Data Sheet

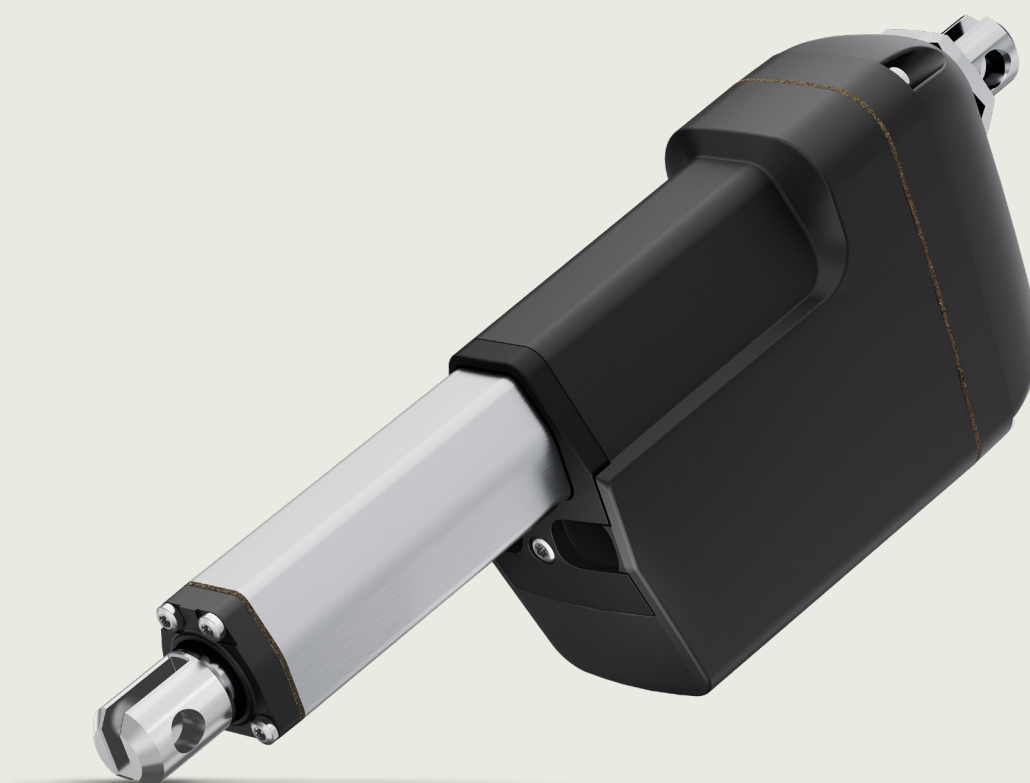

## Contents

Preface .....	3
Terms of use .....	4
Introduction.....	5
Safety instructions.....	5
Features.....	7
Options in general .....	8
Usage.....	9
Ordering Example .....	10
Load vs stroke length .....	12
Technical specifications .....	13
Speed and current curves.....	14
Built-in dimensions.....	17
Stroke and built-in tolerances .....	17
Built-in dimensions to and from measure points.....	18
Back Fixtures.....	20
Back fixture orientation.....	21
Electrical installation.....	21
Current limits .....	22
Max. Current.....	22
Mounting of cables.....	23
Cables .....	24
Power cable dimensions.....	26
9-pin Signal cable dimensions.....	26
Y-cable dimensions .....	26
Plugs.....	27
Actuator Connect cable .....	28
Manual hand crank.....	29
Environmental tests – Climatic .....	30
Environmental tests - Mechanical.....	31
Environmental tests - Electrical .....	31
Contacts.....	32

## Preface

Dear User,

We are delighted that you have chosen a LINAK® product.

LINAK systems are high-tech products based on many years of experience in the manufacture and development of actuators, lifting columns, desk frames, electric control boxes, controls, batteries, accessories and chargers.

This User Manual does not address the end user. It is intended as a source of information for the equipment or system manufacturer only, and it will tell you how to install, use and maintain your LINAK electronics. The manufacturer of the end product has the responsibility to provide a User Manual, where relevant safety information from this manual is passed on to the end user.

We are convinced that your LINAK product/system will give you many years of problem-free operation.

Before our products leave the factory, they undergo both function and quality testing. Should you, nevertheless, experience problems with your product/system, you are always welcome to contact your supplier.

LINAK subsidiaries and some distributors situated all over the world have authorised service centres, which are always ready to help you. Locate your local contact information on the back page.

LINAK provides a warranty on all products. (See warranty section).

This warranty, however, is subject to correct use in accordance with the specifications, maintenance being done correctly, and any repairs being carried out at a service centre, which is authorised to repair LINAK products.

Changes in installation and use of LINAK systems can affect their operation and durability. The products may only be opened by authorised personnel.

This User Manual has been written based on the present technical knowledge. LINAK reserves the right to carry out technical modifications and keeps the associated information updated.

**LINAK A/S**

---

## Terms of use

LINAK® takes great care in providing accurate and up-to-date information on its products. However, the user is responsible for determining the suitability of LINAK products for a specific application.

Due to continual development, LINAK products are subject to frequent modifications and changes. LINAK reserves the rights to conduct modifications, updates, and changes without any prior notice. For the same reason, LINAK cannot guarantee the correctness and actual status of imprinted information on its products.

LINAK uses its best efforts to fulfil orders. However, for the reasons mentioned above, LINAK cannot guarantee availability of any particular product at any given time. LINAK reserves the right to discontinue the sale of any product displayed on its website or listed in its catalogues or in other written material created and produced by LINAK, LINAK subsidiaries, or LINAK affiliates.

All sales are subject to the 'Standard Terms of Sale and Delivery for LINAK A/S' available on LINAK websites.

LINAK and the LINAK logotype are registered trademarks of LINAK A/S. All rights reserved.

## Introduction

The LA21 is a small yet powerful industrial electric linear actuator designed for fast and precise positioning. Featuring an integrated controller, its compact form and broad customization options make it ideal for applications where space is limited but performance is critical.

Engineered to deliver consistent accuracy and reliable positioning, the LA21 is also resilient to harsh industrial conditions, including vibrations, dust, and moisture. Despite its compact size, it includes the same advanced features found in our larger actuators, making it a versatile solution for industries like agriculture, construction, and automation.

## Safety instructions

Please read this safety information carefully.

Be aware of the following three symbols throughout the document:



### Warning!

Failing to follow these instructions can cause accidents resulting in serious personal injury.



### Recommendations

Failing to follow these instructions can result in the actuator suffering damage or being ruined.



### Additional information

Usage tips or additional information that is important in connection with the use of the actuator.

Furthermore, ensure that all staff who are to connect, mount, or use the actuator are in possession of the necessary information and that they have access to this user manual.

Persons who do not have the necessary experience or knowledge of the product/products must not use the product/products. Besides, persons with reduced physical or mental abilities must not use the product/products, unless they are under surveillance or they have been thoroughly instructed in the use of the apparatus by a person who is responsible for the safety of these persons.

Moreover, children must be under surveillance to ensure that they do not play with the product.

### Before you start mounting/dismounting, ensure that the following points are observed:

- The actuator is not in operation.
- The actuator is free from loads that could be released during this work.

### Before you put the actuator into operation, check the following:

- The actuator is correctly mounted as indicated in the relevant user instructions.
- The equipment can be freely moved over the actuator's whole working area.
- The actuator is connected to a suitable electricity supply with the correct voltage.
- Ensure that the voltage applied matches to the voltage specified on the actuator label.
- Ensure that the connection bolts can withstand the wear.
- Ensure that the connection bolts are secured safely.

**During operation, please be aware of the following:**

- Listen for unusual sounds and watch out for uneven running. Stop the actuator immediately if anything unusual is observed.
- Only use the actuator within the specified working limits.
- Do not step on or kick the actuator.

**When the equipment is not in use:**

- Switch off the mains supply in order to prevent unintentional operation.
- Regularly check for excessive wear.

**Classification**

The equipment is not suitable for use in the presence of a flammable anaesthetic mixture with air or with oxygen or nitrous oxide.

**Warnings**

- Do not sideload the actuator
- When mounting the actuator in the application ensure that the bolts can withstand the wear and that they are secured safely
- If irregularities are observed, the actuator must be replaced
- Do not lift or carry the actuator on its cables

**Recommendations**

- Do not place load on the actuator housing
- Prevent impact or blows, or any other form of stress to the housing
- Ensure that the cable cover is mounted correctly. Use 2 Nm torque
- Ensure that the duty cycle and the usage temperatures for actuators are respected
- Ensure that the cable cannot be squeezed, pulled or subjected to any other stress
- During system design -ensure that wire connections are made inside a closed and protective enclosure, to obtain compliance with the IP protection requirements
- Furthermore, it will be good practice to ensure that the actuator is fully retracted in the "normal" position. The reason is that there will be a negative pressure inside the actuator if it is extended which over time can lead to water entering the actuator
- It's good practice to mount the actuator with the motor housing facing upwards and the wires pointing downwards for outdoor applications. This helps protect the motor from environmental elements like rain and debris, ensuring better performance and longevity

## Features

- 12, 24 or 48 V DC permanent magnetic motor  
(12 and 24 V DC available without Integrated Controller)
- Load from 500 N - 3.500 (depending on gear ratio and spindle pitch)
- Max. speed 85 mm/sec. (depending on motor, gear ratio and spindle pitch)
- Stroke length from 50 to 800 mm (with Integrated Controller from 70 to 800 mm)
- Built-in endstops reached function
- Highly efficient acme thread spindle
- Safety factor 2: The actuator has been certified to withstand static loads that are twice the magnitude of its dynamic load capacity without sustaining damage.
- Heavy duty aluminium housing for challenging environmental conditions
- Protection class: IP66 for outdoor use (dynamic). Furthermore, the actuator can be washed down by a high pressure cleaner (IP69K - static)
- Integrated brake with high self-lock ability
- Non-rotating piston rod eye
- Mechanical endstop
- Hand crank for manual operation
- Weight: 2.1 kg for 100 mm stroke; Additional 0.2 kg for each additional 50mm stroke.  
(Cable not included; weight varies by selected options)

## Options in general

- Back Fixture options as male adapter and various slotted in both 0 or 90 degrees
- Piston Rod Eyes options as male adapter, various slotted and ball eyes
- Exchangeable cables in different lengths
- Anodised housing for extreme corroding environments -see paragraph regarding 'Special anodised housing'
- When ordering AISI 304 piston rod eye and back fixture, stainless steel screws are automatically included
- Feedback interfaces:
  - Built-in endstop switches
  - Analogue or digital position feedback from hall effect sensor
- Integrated Controller with contactless incremental encoder, contactless calibration (Zero-point) and following interfaces:
  - I/O
  - CAN SAE J1939
  - CANopen
  - LIN bus
  - Modbus RTU
  - Modbus TCP/IP
  - EtherNet/IP
  - PROFINET
  - IO-Link
- Specific interface user manuals are available at the [TECHLINE webpage](#) containing both Connection Diagrams and I/O Specifications
- PC configuration tool (Actuator Connect™)

## Usage

- Duty cycle up to 800 mm stroke: max. 20% (240 s drive and 960 s rest)
- Ambient operating temperature: Full performance from -20°C to +65°C  
-30 to -20°C (reduced load 50%)  
-40 to -30°C (no load)  
+65 to + 85°C (reduced duty cycle)
- Storage temperature: -40°C to +70°C  
Actuator is not activated/  
connected -55°C to +95°C for 24 hours for Standard platform  
-55°C to +105°C for 24 hours for Integrated Control platform
- Acclimatisation before usage.
- Relative humidity: Full performance from 20% to 80% - non-condensing
- Cyclic state: 93% to 98% - non-condensing +25°C to +55°C for 12 hours
- Steady state 93% to 95% - non-condensing +40 °C for 56 Days
- Atmospheric pressure: 795 to 1060 hPa
- Meters above sea level: Tested to 2000 meters



<b>Piston rod eye</b>	<b>1</b> = Slotted	<b>4</b> = Male Adapter (Outer thread)
		<b>6</b> = Ball eye
<b>Gear</b>	<b>A</b> = Ratio 1:25 (500 N)	<b>B</b> = Ratio 1:37 (900 N, 1,500 N, 2,500 N and 3,500 N)
<b>Brake</b>	<b>1</b> = With Brake	
<b>Built-in dimension</b>	xxxx = Measured in mm	
<b>Endstop reached output*</b>	<b>A</b> = A_HIGH / A_HIGH	
	<b>B</b> = A_LOW / A_HIGH	
	<b>C</b> = A_HIGH / A_LOW	
<b>In/Out</b>	<b>D</b> = A_LOW / A_LOW	
	<b>N</b> = LOW / LOW	
<b>Plug type</b>	<b>0</b> = No plug (when no cable is chosen)	
	<b>J</b> = Deutsch	
	<b>9</b> = Deutsch - Moulded	
	<b>C</b> = Flying leads	<b>E</b> = M12 Y Ethernet
	<b>R</b> = M12 Modbus	<b>N</b> = M12 IO-Link
<b>Cable</b>	<b>0</b> = No cable selected	<b>A</b> = Mounted with 90° angled connectors
	<b>S</b> = Straight cable	<b>Y</b> = Y-Cable (combined power and signal cable)
	<b>V</b> = Y-Cable with 90° angled connectors	
<b>Parallel mode</b>	<b>0</b> = Parallel disabled	<b>2-8</b> = Critical parallel (number of actuators in the parallel system)
<b>SW config.</b>	<b>0</b> = Default software	
<b>Not used</b>	<b>0</b> = Default	

\* A\_High is active high and A\_LOW is active low. HIGH is constant high and LOW is constant low.

Active high: The signal goes from low to high, when the endstop is reached.

Active low: The signal goes from high to low, when the endstop is reached.

Low: The signal stays low at all times.

## Load vs stroke length

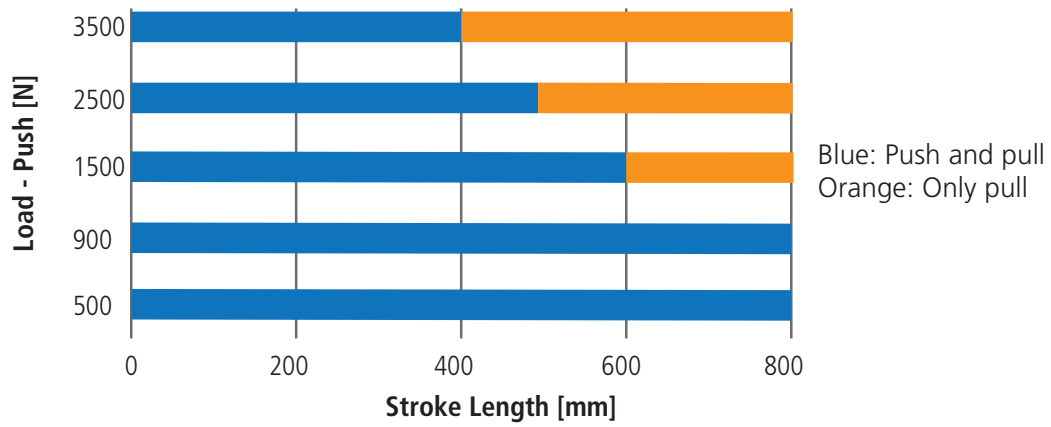

- For applications that only operate in pull, the limitations are 800 mm stroke and 3.500 N load

## Technical specifications

### 12 V

Load max. (N)	Self-lock min. (N)	Pitch (mm/spindle rev.)	Gear/Ratio	Hall Resolution mm/count	End-play in mm	Typical speed* (mm/s) load		IC with regulated Speed (mm/s) ***	Typical amp.*/** (A)	
						No load	Full load		12 V	
									No load	Full load
500	500	20	A 1:25	0.474	2.1	75	67	58	3.5	6.8
900	1,800	15	B 1:37	0.234	1.0	37	33	28	3.0	6.4
1,500	3,000	9	B 1:37	0.140	0.6	21	19	16	3.5	6.7
2,500	5,000	5	B 1:37	0.078	0.4	12	10	9	3.0	8.5
3,500	7,000	3	B 1:37	0.046	0.2	8	6	5	3.0	8.5

### 24 V

Load max. (N)	Self-lock min. (N)	Pitch (mm/spindle rev.)	Gear/Ratio	Hall Resolution mm/count	End-play in mm	Typical speed* (mm/s) load		IC with regulated Speed (mm/s) ***	Typical amp.*/** (A)	
						No load	Full load		24 V	
									No load	Full load
500	500	20	A 1:25	0.474	2.1	75	64	58	1.7	3.7
900	1,800	15	B 1:37	0.234	1.1	36	31	28	1.8	3.5
1,500	3,000	9	B 1:37	0.140	0.7	21	18	16	2.0	4.5
2,500	5,000	5	B 1:37	0.078	0.4	12	10	9	1.5	4.1
3,500	7,000	3	B 1:37	0.046	0.2	8	6	5	1.5	4.5

### 48 V

Load max. (N)	Self-lock min. (N)	Pitch (mm/spindle rev.)	Gear/Ratio	Hall Resolution mm/count	End-play in mm	Typical speed* (mm/s) load		IC with regulated Speed (mm/s) ***	Typical amp.*/** (A)	
						No load	Full load		48 V	
									No load	Full load
500	500	20	A 1:25	0.474	2.1	85	80	78	1	2.5
900	1,800	15	B 1:37	0.234	1.1	42	39	38	1	2.5
1,500	3,000	9	B 1:37	0.140	0.6	25	23	22	1	2.5
2,500	5,000	5	B 1:37	0.078	0.4	15	14	12	1	2.5
3,500	7,000	3	B 1:37	0.046	0.2	11	10	7	1	2.5

\* The typical values can have a variation of  $\pm 20\%$  on the current values and  $\pm 10\%$  on the speed values. Measurements are made with an actuator in connection with a stable power supply and an ambient temperature at  $20^{\circ}\text{C}$ .

\*\* Depending on temperature (see speed and current curves).

\*\*\* By default, the IC Actuator operates with unregulated speed. To enable regulated speed, set the ramp-down time stop setting to any value other than 0.



To maximise the self-locking ability, ensure that the motor is shorted when stopped. (The shown self-locking values are measured without shorted motor).

-Actuators with an Integrated Controller provide this feature as long as the actuator is powered.

## Speed and current curves

The typical values below are made with a stable power supply and an ambient temperature of 20°C.

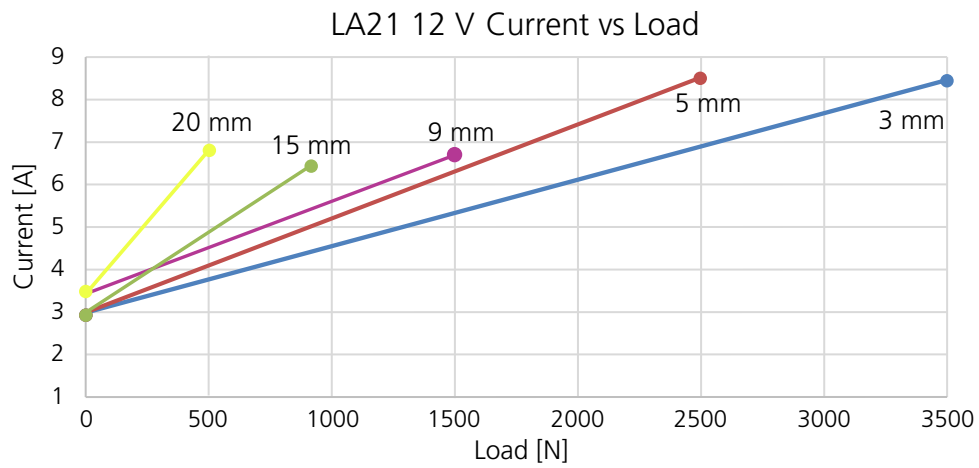
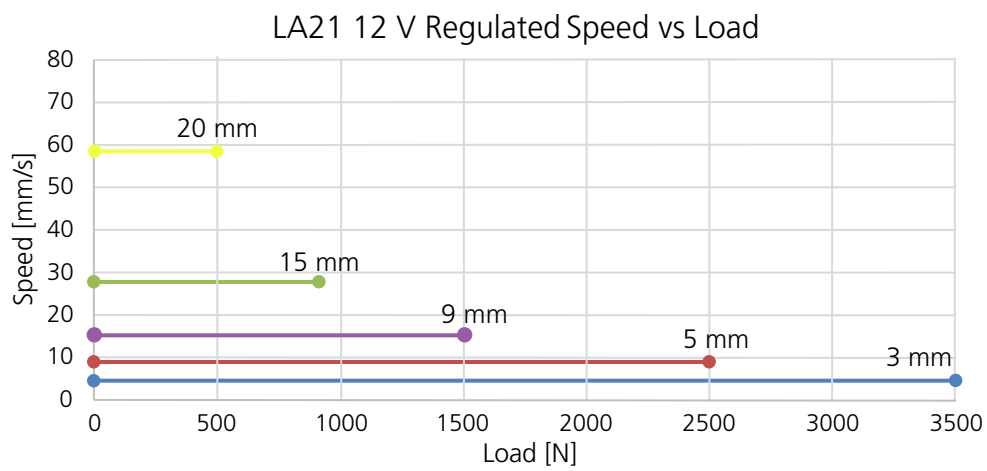
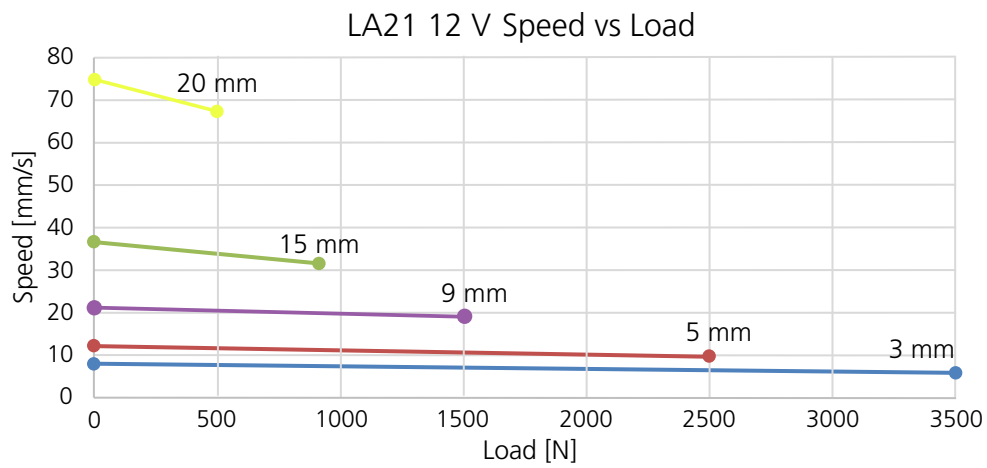

The typical values below are made with a stable power supply and an ambient temperature of 20°C.

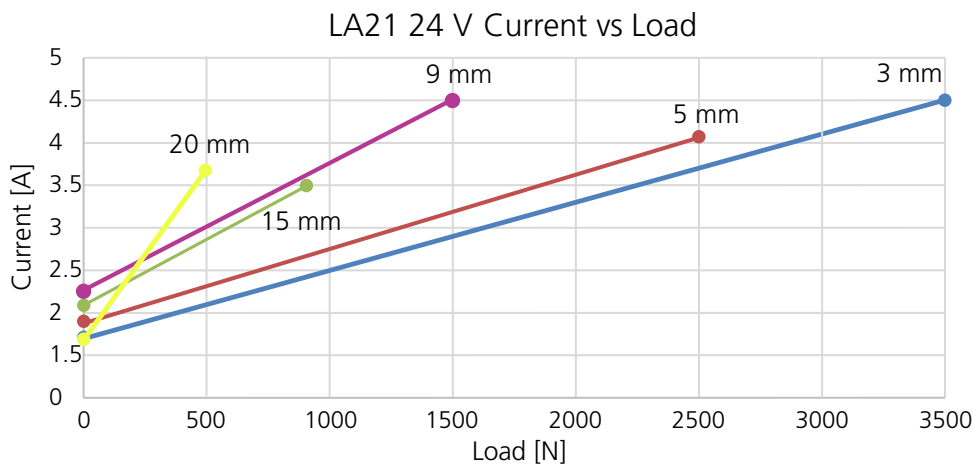
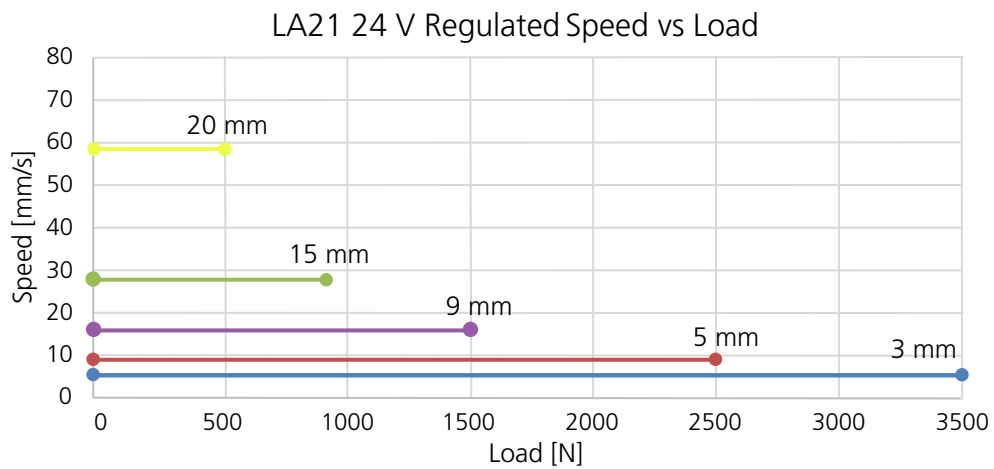
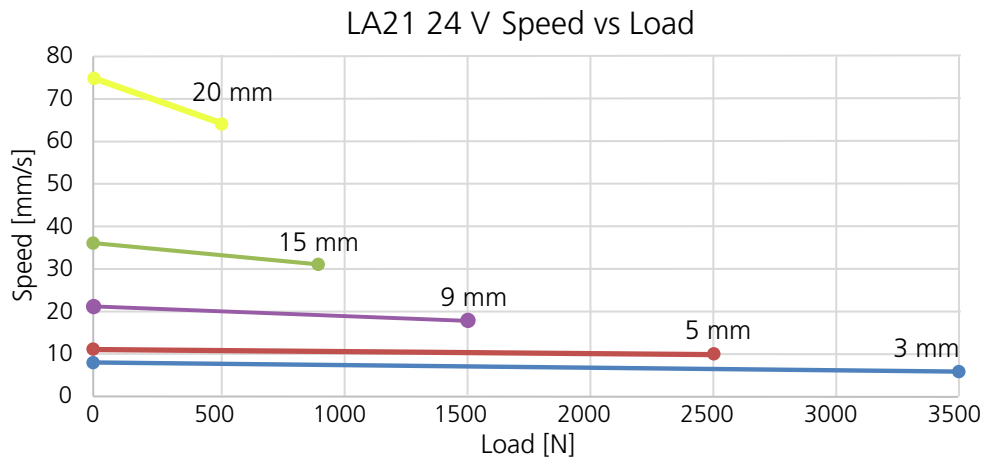

The typical values below are made with a stable power supply and an ambient temperature of 20°C.

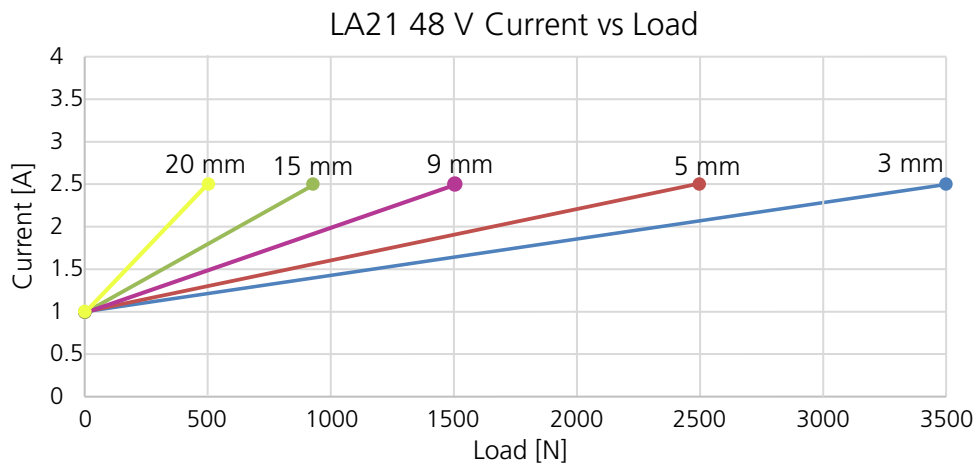
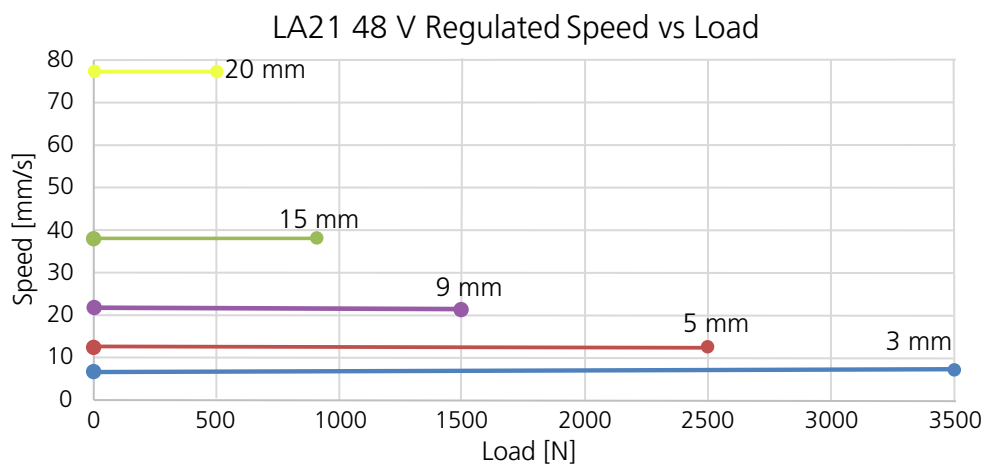
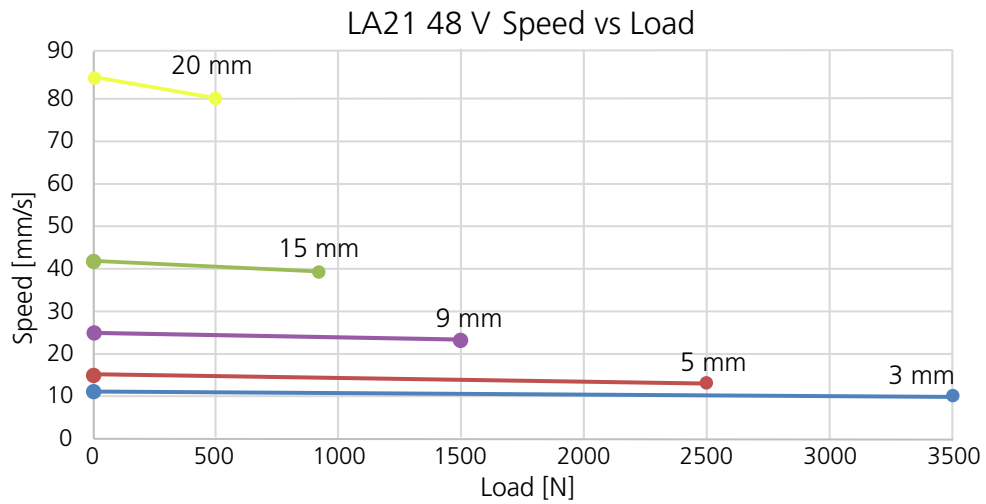

## Built-in dimensions

All dimensions are in mm

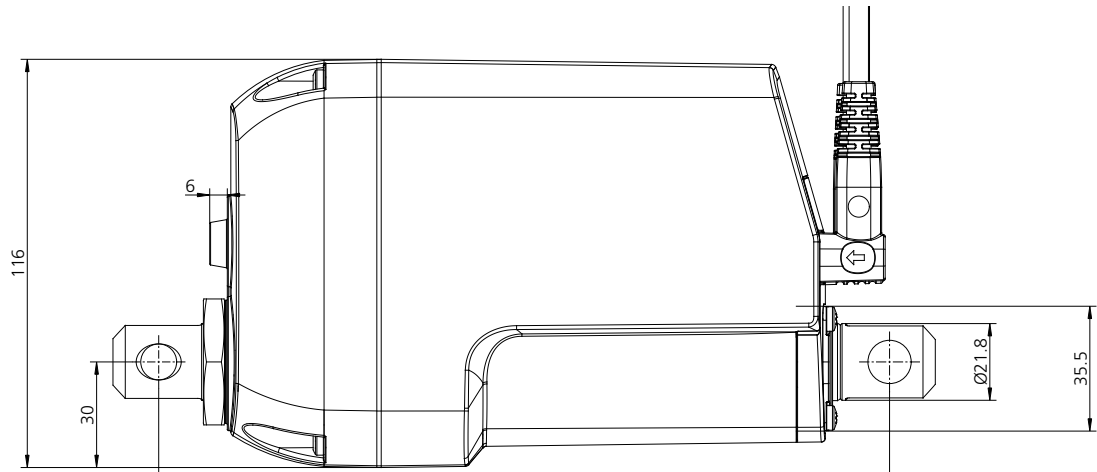

When STROKE  $\leq 300$  = Built-in dimension; 156+STROKE LENGTH -(Shortest BiD 209 mm - 226 mm for Zero Point)  
 When STROKE  $> 300$  = Built-in dimension; 206+STROKE LENGTH

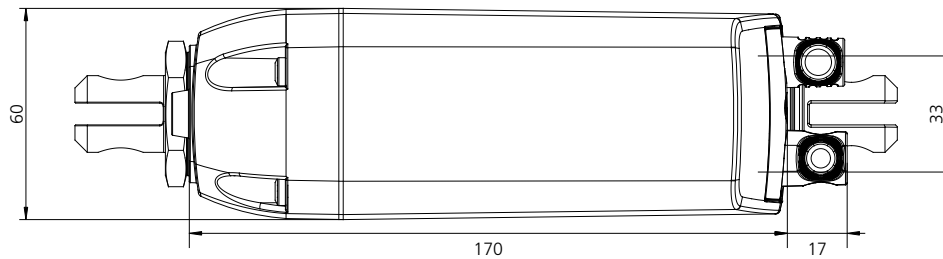

When selecting a piston rod eyes and back fixtures the built-in dimensions of the actuator can change. Please check this in the corresponding chapters

## Stroke and built-in tolerances

Platforms		Stroke tolerance	Example for 200 mm stroke	BiD tolerance	Example for 356 mm BiD
01	Standard with power switch	$\pm 1$ mm	199 to 201 mm	$\pm 1$ mm	355 to 357 mm
B3	I/O Basic	$\pm 1$ mm	199 to 201 mm	$\pm 1$ mm	355 to 357 mm
C3	I/O Customised				
F3	I/O Full				
0B	IO-Link				
14	Modbus RTU				
A7	SAE CAN J1939				
A8	CANopen				
2E	EtherNet/IP				
0E	Modbus TCP/IP	$\pm 1$ mm	199 to 201 mm	$\pm 1$ mm	355 to 357 mm
14	Modbus RTU				
37	SAE CAN J1939 Off-highway	$\pm 1$ mm	199 to 201 mm	$\pm 1$ mm	355 to 357 mm
38	CANopen Off-highway				

### Built-in dimensions to and from measure points

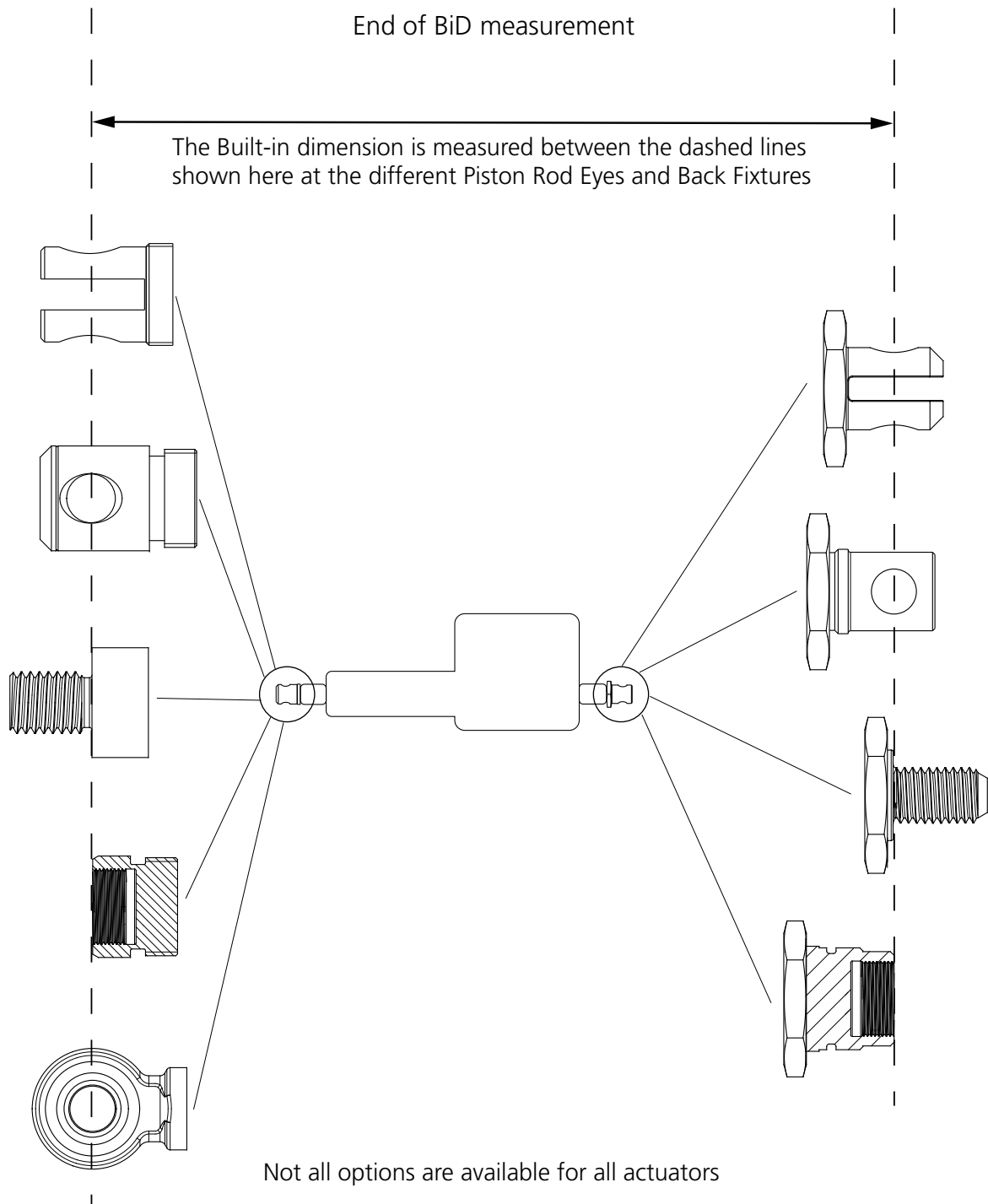

### Keep a clearance when mounting a bracket

 When mounting a custom bracket on the moving part of the actuator, please observe the minimum clearance between bracket and cylinder top when fully retracted. This will prevent jamming and destruction of the actuator drive train.

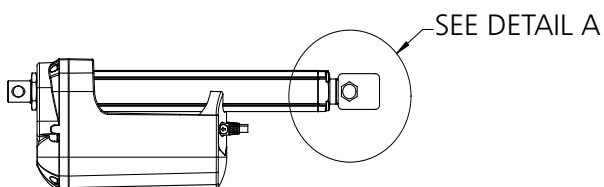

DETAIL A

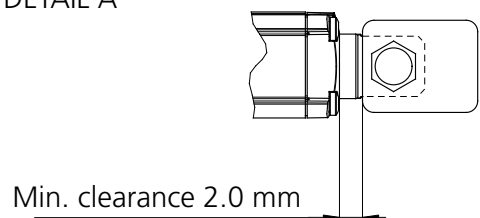

### Piston Rod Eyes

All dimensions are in mm. Piston rod eyes are allowed to turn 0-180°

Option	Piston Rod Eye	Material	A	B	C	D	E	F (~)	G	Change in BiD	P/N
1	Slotted	Zink coated steel	Ø 10.2	25.1	21.8	13	6.2	26.2	-	0	0231033
1	Slotted	AISI 304	Ø 10.2	25.1	21.8	13	6.2	26.2	-	0	0231096
1	Slotted	Zink coated steel	Ø 12.2	25.1	21.8	13	6.2	26.2	-	0	0331036
1	Slotted	AISI 304	Ø 12.2	25.1	21.8	13	6.2	26.2	-	0	0331140
1	Slotted	Zink coated steel	Ø 12.9	25.1	21.8	13	6.2	26.2	-	0	0331014
1	Slotted	AISI 304	Ø 12.9	25.1	21.8	13	6.2	26.2	-	0	0331139
1	Slotted	Zink coated steel + bushings	Ø 10.2	25.1	21.8	13	6.2	26.2	26	0	0231016
1	Slotted	AISI 304 + bushings	Ø 10.2	25.1	21.8	13	6.2	26.2	26	0	0231095

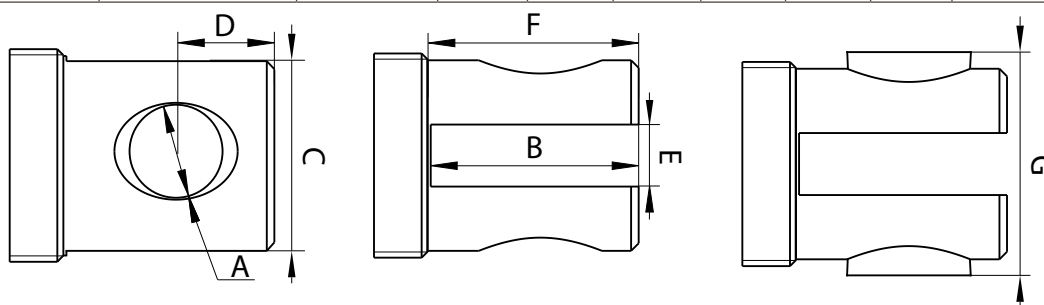

4	Male adaptor	AISI 304	M12 X 1.75	16	21.3	-	17.9	27	-	-3	0231094
---	--------------	----------	------------	----	------	---	------	----	---	----	---------

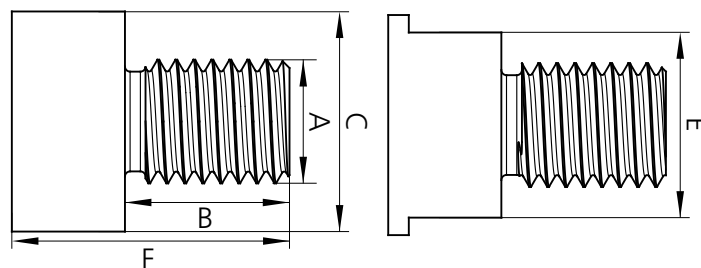

6	Ball eye	AISI 304 (Ball only 440C)	Ø 10 H7	32	14	-	-	-	-	+11	0351053
6	Ball eye	AISI 304 (Ball only 440C)	Ø 12 H7	32	16	-	-	-	-	+11	0351055

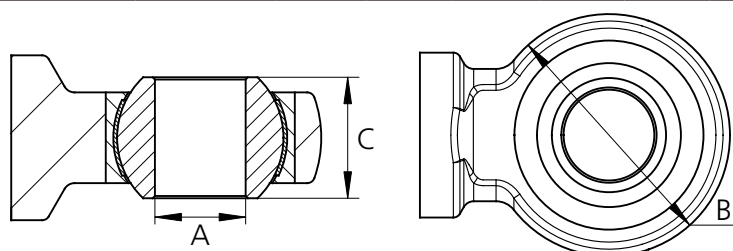

## Back Fixtures

All dimensions are in mm

Option	Back Fixture	Material	A	B	C	D	E	F (~)	G	Change in BiD	P/N
1 or 2	Slotted	Zink coated steel	Ø 10.2	25.1	21.8	13	6.2	26.2	-	0	1086W1026
1 or 2	Slotted	Zink coated steel	Ø 12.2	25.1	21.8	13	6.2	26.2	-	0	1086W1052
1 or 2	Slotted	Zink coated steel	Ø 12.9	25.1	21.8	13	6.2	26.2	-	0	1086W1053
1 or 2	Slotted	AISI 304	Ø 10,2	25.1	21.8	13	6.2	26.2	-	0	1086W1059
1 or 2	Slotted	AISI 304	Ø 12.2	25.1	21.8	13	6.2	26.2	-	0	1086W1056
1 or 2	Slotted	AISI 304	Ø 12.9	25.1	21.8	13	6.2	26.2	-	0	1086W1057
1 or 2	Slotted	Zink coated steel + POM bushings	Ø 10.2	25.1	21.8	13	6.2	26.2	26	0	1086W1062
1 or 2	Slotted	AISI 304 + POM bushings	Ø 10.2	25.1	21.8	13	6.2	26.2	26	0	1086W1063

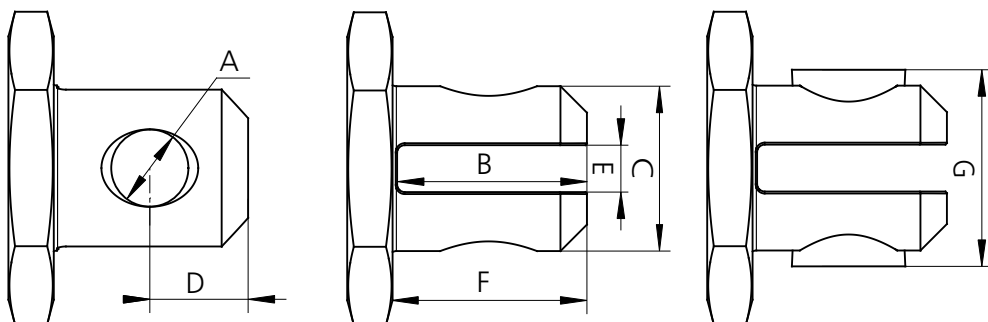

4	Male adapter	AISI 304	M12 X 1.75	25.0	-	-	-	27.0	-	-11	1086W1058
---	--------------	----------	------------	------	---	---	---	------	---	-----	-----------

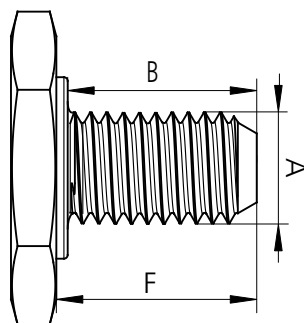

## Back fixture orientation

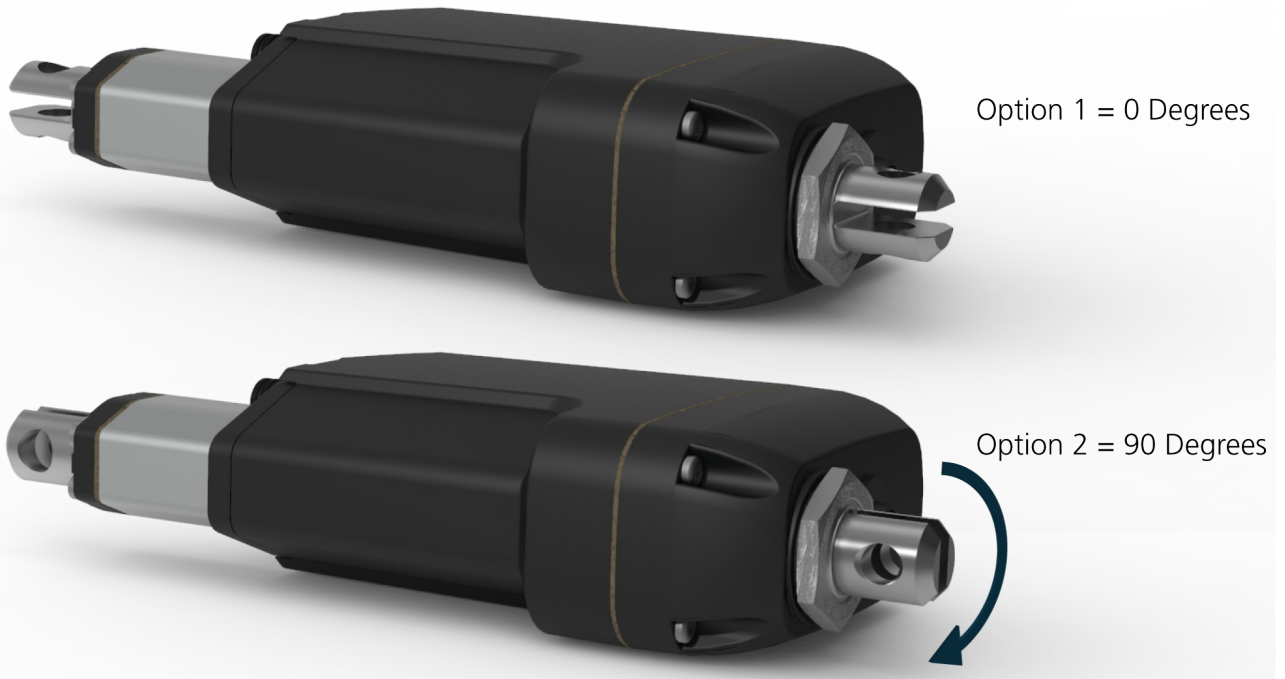

## Electrical installation



- To ensure maximum self-locking ability, please be sure that the motor is shorted when stopped. Actuator with Integrated Controller provide this feature, as long as the actuator is powered.
- When using soft stop on a DC-motor, the actuator can send a short high-voltage pulse to the power supply. It is important to make sure that it does not turn off the output when this backwards load dump occurs.
- The actuator includes a soft stop feature with a duration of 300 ms. This minimizes voltage peaks sent back to the power supply. Ensure the selected power supply does not disable the output during these reverse load dumps.
- The actuator utilizes a Hall-based position system. To maintain reliable position feedback throughout the product's lifespan, the actuator must be capable of recalibration within the application.

### Calibration process

- **Without Integrated Controller:** Calibration is performed when the actuator moves to the endstop position in either direction and activates the endstop switch.
  - **With Integrated Controller:** Calibration is performed when the actuator moves outward over a range of 35-70 mm in one continuous motion, without altering speed or stopping
-  For actuators without an Integrated Controller, ensure the power supply is monitored externally. It must be disconnected in the event of a current overload to prevent damage. IC actuators come with built-in overcurrent protection, eliminating the need for external monitoring.

## Current limits

As described in the algorithm on previous page

Platform		12 V	24 V	48 V	Reference temperature: 0°C
B3 C3 F3	I/O Basic	10 A	5 A	4 A	Above
	I/O Customised I/O Full				15 A
0B	IO-Link	-	5 A	-	Above
		-	10 A	-	Below
14	Modbus RTU	-	5 A	4 A	Above
		-	10 A	6 A	Below
A7 A8	CANbus J1939 CANopen	-	5 A	4 A	Above
		-	10 A	6 A	Below
0E 2E 4E	Modbus TCP/IP Ethernet PROFINET	-	5 A	4 A	Above
		-	10 A	6 A	Below
37 38	CAN bus J1939 Off-highway CANopen Off-highway	10 A	5 A	-	Above
		15 A	10 A	-	Below

## Max. Current

The current is not limited by actuators without Integrated Controller.

The value shown below represents the anticipated current consumption at maximum load.

For more details, refer to: "Recommended fuse for actuators without Integrated Controller" In the user manual.

Platform		12 V	24 V	Reference temperature: 0°C
01	Standard with power switch	8 A	5 A	Above
		8 A	5 A	Below

## Mounting of cables

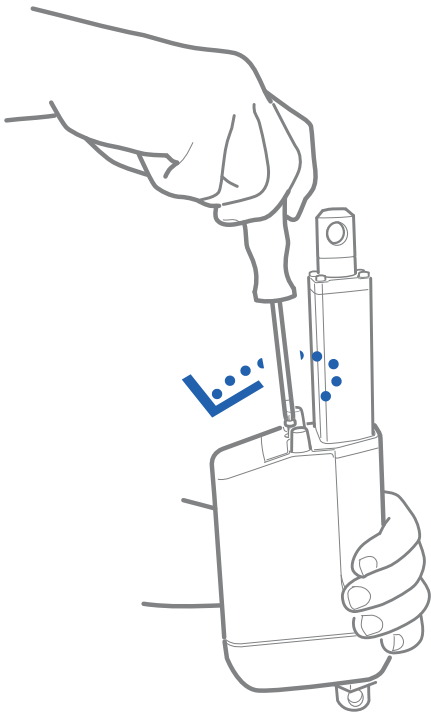

Unscrew the screw and separate the cover from the housing. Remove the blind plug(s).

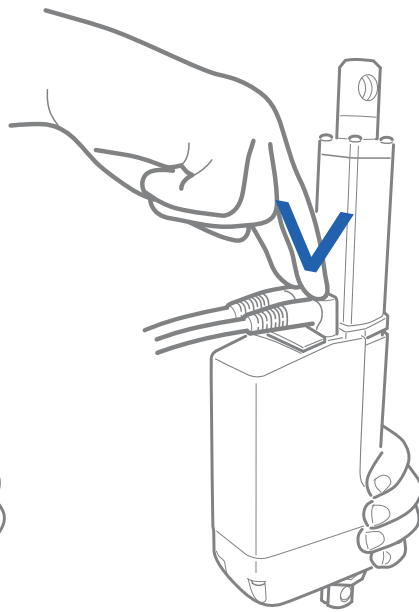

Place the plug(s) with the power cable and/or the signal cable in the cover. Slide the cover onto the actuator. Make sure the plugs are plugged in.

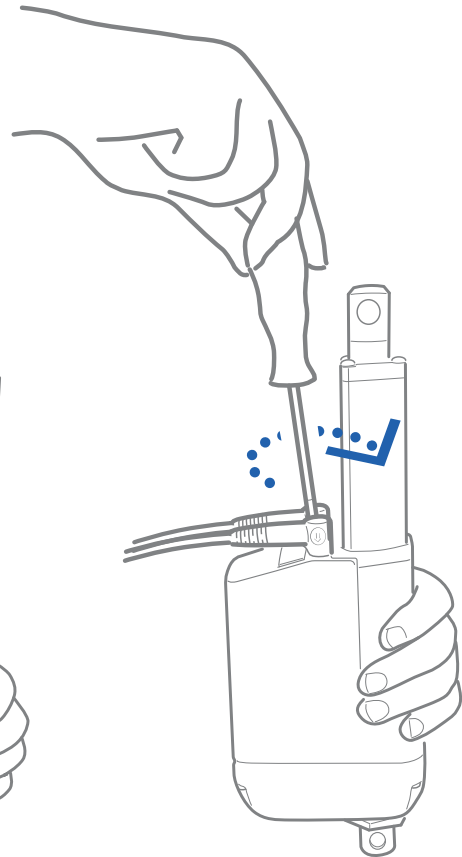

Tighten the screw again.

The torque of the cover screw should be:  $2 \pm 0.3$  Nm  
TORX 15IP

 When changing the cables on a LINAK® actuator, it is important that this is done carefully, in order to protect the plugs and pins. Before the new cable is mounted, we recommend that the socket is greased with vaseline®, to keep the high IP protection and ensure an easy mounting. Please be sure that the plug and gasket are in the right location and fully pressed in before the cable lid is tightened.

Cut off the tinned end if you connect the cable with screws. The tinned end is only to be used when a soldered connection is made.

Please note that if the cables are mounted and dismantled more than 3 times the plugs can be damaged. Therefore, we recommend that such cables are discarded and replaced.

Do not lift the actuator by the cables.

We recommend to take some precaution and design the wire connection in a way, where the cable end is kept inside a closed, protected area to guarantee the high IP protection.

## Cables

Cable P/N Table					
Option	Cable type	# Wires	mm <sup>2</sup>	Length in mm	LINAK P/N
S	Power cable	2	2.0	1,500	CAB0367046-1500
S	Power cable	2	2.0	5,000	CAB0367046-5000
S	Power cable	2	2.0	10,000	CAB0367046-10000
<p>CAB0367046</p> <p>Length <math>\varnothing 7.5 \pm 0.15 \text{ mm}</math></p>					
S	Straight signal cable	9	0.5	1,500	CAB0368543-1500
S	Straight signal cable	9	0.5	5,000	CAB0368543-5000
S	Straight signal cable	9	0.5	10,000	CAB0368543-10000
<p>CAB0368543</p> <p>Length <math>\varnothing 7.5 \pm 0.15 \text{ mm}</math></p>					
S	Ethernet connection cable	9	0.5	600	CAB0367402
<p>CAB0367402</p> <p>Length <math>\varnothing 7.5 \pm 0.15 \text{ mm}</math></p> <p><math>280 \pm 20</math></p> <p><math>\varnothing 5.5 \pm 0.15</math></p>					
S	IO-Link connection cable	5	0.5	600	CAB0367299
<p>CAB0367299</p> <p>Length <math>\varnothing 5.5 \pm 0.15</math></p>					
S	Modbus RTU connection	5	0.5	1000	CAB 0965633-1000
<p>CAB0965633</p> <p>Attention: no O-ring</p> <p>Length <math>\varnothing 7.0 \pm 0.15 \text{ mm}</math></p>					
A	Angled power cable	2	2.0	1,500	CAB0367155-1500
<p>CAB0367155</p> <p>Length <math>\varnothing 7.0 \pm 0.15 \text{ mm}</math></p> <p><math>5 \pm 1</math> tinned</p> <p><math>30 \pm 5</math></p>					
A	Angled signal cable	9	0.5	1,500	CAB0367413-1500

Cable P/N Table					
Option	Cable type	# Wires	mm <sup>2</sup>	Length in mm	LINAK P/N
	<p>CAB0367413 25±5 Length Ø 7.5 ± 0.15 mm</p>				
Y	Straight Y-cable Power and Signal	2 9	2.0 0.5	1,500	CAB0367430-1500
Y	Straight Y-cable Power and Signal	2 9	2.0 0.5	5,000	CAB0367430-5000
Y	Straight Y-cable Power and Signal	2 9	2.0 0.5	10,000	CAB0367430-10000
	<p>CAB0367430 5±1 Tinned 50±5 Length Ø 10.6 ± 0.15 Ø 7.5 ± 0.15</p>				
V	Angled Y-cable Power and Signal	2 9	2.0 0.5	1,500	CAB0367440-1500
	<p>CAB0367441 5±1 Tinned 50±5 Length Ø 10.6 ± 0.15 110±10 Ø 7.5 ± 0.15</p>				

## Power cable dimensions

Colour	Outer dimensions	Wire mm <sup>2</sup>	Pin
Blue	Ø2.8 mm	2.0	1
Brown	Ø2.8 mm	2.0	2

## 9-pin Signal cable dimensions

Colour	Outer dimensions	Wire mm <sup>2</sup>	Pin
Black	Ø1.5 mm	0.5	1
Red	Ø1.5 mm	0.5	2
Yellow	Ø1.5 mm	0.5	3
Green	Ø1.5 mm	0.5	4
Orange	Ø1.5 mm	0.5	5
Light Blue	Ø1.5 mm	0.5	6
Violet	Ø1.5 mm	0.5	7
White	Ø1.5 mm	0.5	8
Grey	Ø1.5 mm	0.5	-

## Y-cable dimensions

Colour	Outer dimensions	Wire mm <sup>2</sup>	Pin
Blue	Ø2.8 mm	2.0	1
Brown	Ø2.8 mm	2.0	2
Orange	Ø1.5 mm	0.5	3
Yellow	Ø1.5 mm	0.5	4
Green	Ø1.5 mm	0.5	5
Black	Ø1.5 mm	0.5	6
Red	Ø1.5 mm	0.5	7
Light Blue	Ø1.5 mm	0.5	8
Violet	Ø1.5 mm	0.5	9
White	Ø1.5 mm	0.5	10
Grey	Ø1.5 mm	0.5	-

## Plugs

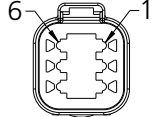
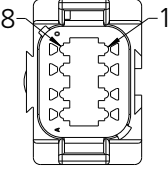
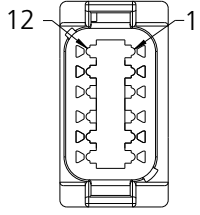
Plug type	Deutsch
2-pin	 <p>DTP04-xP</p>
6-pin	 <p>DT04-xP-CO15</p>
8-pin	 <p>DT04-xP-CO15</p>
12-pin	 <p>DT04-xP-CE02</p>

## Actuator Connect cable

Actuator Connect™ cable					
Option	Platform	Pins	Includes	Colour	Article no.
B3	I/O Basic	Signal-power + RJ45	Adapter + USB2Lin	Grey	0367996
C3	I/O Customised				
F3	I/O Full				
0B	IO-Link				
A7	SAE CAN J1939				
A8	CANopen				
2E	EtherNet/IP				
0E	Modbus TCP/IP				
4E	PROFINET				
14	Modbus RTU				
37	SAE CAN J1939 Off-highway				
38	CANopen Off-highway				

Latest versions of both Actuator Connect® can be downloaded at the [LINA/TECHLINE](#) page.

## Manual hand crank

The manual Hand Crank can be used in the case of a power failure and is only intended for emergency use.



The cover over the Torx socket must be unscrewed before the Torx 15 driver can be inserted and the hand crank operated.

Hand crank torque: 6 Nm

Hand crank rpm: Max. 65

<b>Piston rod movement per turn:</b>					
Spindle pitch	3 mm	5 mm	9 mm	15 mm	20 mm
Gear A	-	-	-	-	14
Gear B	1.4	2.3	4.2	7	-

## Environmental tests – Climatic

Test	Specification	Comment
Cold Test		Min. operation temperature : -40°C for 72 hours (Actuator is connected but not activated) Min. storage temperature : -55°C for 24 hours (Actuator is not activated/connected)
Dry Heat		Max. operation temperature : +85°C for 72 hour (Actuator is connected but not activated) Max. storage temperature : +105°C for 24 hours (Actuator is not activated/connected)

Test	Specification	Comment
Storage in Moisture	EN 60068-2-30	Temperature : +40°C and humidity cycling up to 100 % RH. Actuator operated with 20% duty cycle
Operating in Moisture	EN 60068-2-7	The actuators are tested at +40°C at 93% relative humidity for 21 days
Degrees of Protection	EN 60529 – IP66	IP6X - Dust: Dust-tight, No ingress of dust Actuator is not activated IPX6 - Water: Ingress of water in quantities causing harmful effects is not allowed Duration: 100 liters per minute in 3 minutes Actuator is not activated
	DIN 40050 – IP69K	IPX9K: High pressure cleaner Temperature: +90°C Water pressure: 350 bar Duration: 30 sec. in each direction. Actuator is not activated Ingress of water in quantities causing harmful effects is not allowed
Dunk test		The actuator has been warmed up to 85 °C for 4 hours. After this it is cooled down in 0 °C salt water. Cooling time: 2 hours. This is done 5 times.
Chemicals	BS 7691 Section 6.11.2.4	Diesel Hydraulic Oil Ethylene Glycol Urea Nitrogen Diesel Exhaust Fluid (DEF) NPK Fertilizer* (7.5% each N P & K) Liquid Lime
<b>Harsh -Housing option: 9</b>		
Salt Mist	DS/EN ISO 9227	The salt spray test is performed according to DS/EN ISO 9227 "Corrosion tests in artificial atmospheres" at 35±2°C The assembled housings are unpowered. Test duration is 500 hours

## Environmental tests - Mechanical

Test	Specification	Comment
Drop test		2 drops on 6 faces onto a concrete floor. Drop height: 1000 mm
Vibration random	The specification is based on ISO 16750-3:2012(E) Test VII and should therefore be performed according to IEC 60068-2-64, random vibration. The PSD level is increased in the frequency range from 10 to 400 [Hz]	From 10 Hz to 2000 Hz Duration: 32 h/axis Acceleration: 6.9 [grms]

## Environmental tests - Electrical

Test	Specification	Comment
	EN/IEC 60204-1:2018	Safety for machinery - Electrical equipment of machines - Part 1: General requirements
Immunity	EN/IEC 61000-6-1:2019	Electromagnetic compatibility (EMC) - Part 6-1: Generic standards - immunity for residential, commercial and light industrial environments
Immunity	EN/IEC 61000-6-2:2019	Electromagnetic compatibility (EMC) - Part 6-2: Generic standards - immunity for industrial environments
Emission	EN/IEC 61000-6-4:2019	Electromagnetic compatibility (EMC) - Part 6-4: Generic standards - emission standards for industrial environments
<b>Off-highway -Platform option: 37 &amp; 38</b>		
	ISO 16750-2:2012 +A1:2011	Environmental conditions and testing for electrical and electronic equipment - Part 2: Electrical loads
	ISO 7637-2:2011	Electrical disturbances from conduction and coupling - Part 2: Electrical transient conduction along supply lines only
Automotive Transients	ISO 7637-3:2007	Electrical disturbances from conduction and coupling - Part 3: Electrical transient transmission by capacitive coupling via lines other than supply lines
	CISPR 25 IEC:2008	Radio disturbance characteristics - Limits and methods of measurement for the protection of on-board receivers

# Contacts

## FACTORIES

Denmark - Headquarters  
LINAK A/S  
Phone: +45 73 15 15 15  
Fax: +45 74 45 80 48  
Fax (Sales): +45 73 15 16 13  
Web: www.linak.com

China  
LINAK (Shenzhen) Actuator Systems, Ltd.  
Phone: +86 755 8610 6656  
Phone: +86 755 8610 6990  
Web: www.linak.cn

Slovakia  
LINAK Slovakia s.r.o.  
Phone: +421 51 7563 444  
Web: www.linak.sk

Thailand  
LINAK APAC Ltd.  
Phone: +66 33 265 400  
Web: www.linak.com

USA  
LINAK U.S. Inc.  
Americas Headquarters  
Phone: +1 502 253 5595  
Fax: +1 502 253 5596  
Web: www.linak-us.com  
www.linak-latinamerica.com

## SUBSIDIARIES

Australia  
LINAK Australia Pty. Ltd  
Phone: +61 3 8796 9777  
Fax: +61 3 8796 9778  
E-mail: sales@linak.com.au  
Web: www.linak.com.au

Austria  
LINAK Zweigniederlassung - Österreich (Wien)  
Phone: +43 (1) 890 7446  
Fax: +43 (1) 890 744615  
E-mail: info@linak.de  
Web: www.linak.at - www.linak.hu

Belgium  
LINAK Actuator-Systems NV/SA (Belgium & Luxembourg)  
Phone: +32 (0)9 230 01 09  
E-mail: beinfo@linak.be  
Web: www.linak.be - www.fr.linak.be

Brazil  
LINAK Do Brasil Comércio De Atuadores Ltda.  
Phone: +55 (11) 2832 7070  
Fax: +55 (11) 2832 7060  
E-mail: info@linak.com.br  
Web: www.linak.com.br

Canada  
LINAK Canada Inc.  
Phone: +1 502 253 5595  
Fax: +1 416 255 7720  
E-mail: info@linak.ca  
Web: www.linak-us.com

Czech Republic  
LINAK C&S s.r.o.  
Phone: +42 058 174 1814  
Fax: +42 058 170 2452  
E-mail: info@linak.cz  
Web: www.linak.cz - www.linak.sk

Denmark - International  
LINAK International  
Phone: +45 73 15 15 15  
E-mail: info@linak.com  
Web: www.linak.com

Denmark - Sales  
LINAK Danmark A/S  
Phone: +45 86 80 36 11  
Fax: +45 86 82 90 51  
E-mail: linak@linak-silkeborg.dk  
Web: www.linak.dk

Finland  
LINAK OY  
Phone: +358 10 841 8700  
E-mail: linak@linak.fi  
Web: www.linak.fi

France  
LINAK France E.U.R.L  
Phone: +33 (0) 2 41 36 34 34  
Fax: +33 (0) 2 41 36 35 00  
E-mail: linak@linak.fr  
Web: www.linak.fr

Germany  
LINAK GmbH  
Phone: +49 6043 9655 0  
Fax: +49 6043 9655 60  
E-mail: info@linak.de  
Web: www.linak.de

India  
LINAK A/S India Liaison Office  
Phone: +91 120 4531797  
Fax: +91 120 4786428  
E-mail: info@linak.in  
Web: www.linak.in

Ireland  
LINAK UK Limited (Ireland)  
Phone: +44 (0)121 544 2211  
Fax: +44 (0)121 544 2552  
+44 (0)796 855 1606 (UK Mobile)  
+35 387 634 6554 (Rep.of Ireland Mobile)  
E-mail: sales@linak.co.uk  
Web: www.linak.co.uk

Italy  
LINAK ITALIA S.r.l.  
Phone: +39 02 48 46 33 66  
Fax: +39 02 48 46 82 52  
E-mail: info@linak.it  
Web: www.linak.it

Japan  
LINAK K.K.  
Phone: 81-45-533-0802  
Fax: 81-45-533-0803  
E-mail: linak@linak.jp  
Web: www.linak.jp

Malaysia  
LINAK Actuators Sdn. Bhd.  
Phone: +60 4 210 6500  
Fax: +60 4 226 8901  
E-mail: info@linak-asia.com  
Web: www.linak.my

Netherlands  
LINAK Actuator-Systems B.V.  
Phone: +31 76 5 42 44 40 / +31 76 200 11 10  
E-mail: info@linak.nl  
Web: www.linak.nl

New Zealand  
LINAK New Zealand Ltd  
Phone: +64 9580 2071  
Fax: +64 9580 2072  
E-mail: nzsales@linak.com.au  
Web: www.linak.com.au

Norway  
LINAK Norge AS  
Phone: +47 32 82 90 90  
E-mail: info@linak.no  
Web: www.linak.no

Poland  
LINAK Polska  
LINAK Danmark A/S (Spółka Akcyjna)  
Phone: +48 22 295 09 70 / +48 22 295 09 71  
E-mail: info@linak.pl  
Web: www.linak.pl

Republic of Korea  
LINAK Korea Ltd.  
Phone: +82 2 6231 1515  
Fax: +82 2 6231 1516  
E-mail: info@linak.kr  
Web: www.linak.kr

Slovakia  
LINAK Slovakia S.R.O.  
Phone: +421 51 7563 444  
Web: www.linak.sk

Spain  
LINAK Actuadores, S.L.u  
Phone: +34 93 588 27 77  
Fax: +34 93 588 27 85  
E-mail: esma@linak.es  
Web: www.linak.es

Sweden  
LINAK Scandinavia AB  
Phone: +46 8 732 20 00  
Fax: +46 8 732 20 50  
E-mail: info@linak.se  
Web: www.linak.se

Switzerland  
LINAK AG  
Phone: +41 43 388 31 88  
E-mail: info@linak.ch  
Web: www.linak.ch - www.fr.linak.ch  
www.it.linak.ch

Taiwan  
LINAK (Shenzhen) Actuator systems Ltd.  
Taiwan Representative office  
Phone: +886 2 272 90068  
Fax: +886 2 272 90096  
E-mail: sales@linak.com.tw  
Web: www.linak.com.tw

Turkey  
LINAK İth. İhr. San. ve Tic. A.Ş.  
Phone: +90 312 4726338  
Fax: +90 312 4726635  
E-mail: info@linak.com.tr  
Web: www.linak.com.tr

United Kingdom  
LINAK UK Limited  
Phone: +44 (0)121 544 2211  
Fax: +44 (0)121 544 2552  
E-mail: sales@linak.co.uk  
Web: www.linak.co.uk

## DISTRIBUTORS

Argentina  
Novotec Argentina SRL  
Phone: 011-4303-8989 / 8900  
Fax: 011-4032-0184  
E-mail: info@novotecargentina.com  
Web: www.novotecargentina.com

Colombia  
MEM Ltda  
Phone: +[57] (1) 334-7666  
Fax: +[57] (1) 282-1684  
E-mail: servicioalcliente@memltda.com.co  
Web: www.mem.net.co

India  
Mechatronics Control Equipments India Pvt Ltd  
Phone: +91-44-28558484, 85  
E-mail: bala@mechatronicscontrol.com  
Web: www.mechatronicscontrol.com

Indonesia  
PT. Himalaya Everest Jaya  
Phone: +6 221 544 8956 /+6 221 544 8965  
Fax: +6 221 619 1925  
Fax (Sales): +6 221 619 4658  
E-mail: hejplastic-div@centrin.net.id  
Web: www.hej.co.id

Israel  
NetivTech LTD  
Phone: +972 55-2266-535  
Fax: +972 2-9900-560  
E-mail: info@NetivTech.com  
Web: www.netivtech.com

Singapore  
Servo Dynamics Pte Ltd  
Phone: +65 6844 0288  
Fax: +65 6844 0070  
E-mail: servodynamics@servo.com.sg

South Africa  
Industrial Specialised Applications CC  
Phone: +27 011 466 0346  
E-mail: gartht@isagroup.co.za  
Web: www.isaza.co.za

United Arab Emirates  
Mechatronics  
Phone: +971 4 267 4311  
Fax: +971 4 267 4312  
E-mail: mechtron@emirates.net.ae

## Terms of use

LINAK® takes great care in providing accurate and up-to-date information on its products. However, the user is responsible for determining the suitability of LINAK products for a specific application. Due to continual development, LINAK products are subject to frequent modifications and changes. LINAK reserves the rights to conduct modifications, updates, and changes without any prior notice. For the same reason, LINAK cannot guarantee the correctness and actual status of imprinted information on its products.

LINAK uses its best efforts to fulfil orders. However, for the reasons mentioned above, LINAK cannot guarantee availability of any particular product at any given time. LINAK reserves the right to discontinue the sale of any product displayed on its website or listed in its catalogues or in other written material created and produced by LINAK, LINAK subsidiaries, or LINAK affiliates. All sales are subject to the 'Standard Terms of Sale and Delivery for LINAK A/S' available on LINAK websites. LINAK and the LINAK logotype are registered trademarks of LINAK A/S. All rights reserved.