



BusLink User Guide

Contents

Guide to connecting the actuator to BusLink	3-4
Configure the IC actuator with BusLink 2 software	5-11
Controls.....	5-7
Configure	5
Calibration.....	6
Virtual- and Current Limit.....	7
Speed	8
Soft Stop/Soft Start.....	8
Feedback Types	9-11
PWM.....	9
Single Hall	9
Current Feedback.....	10
Voltage Feedback.....	10
Monitoring	11
Service.....	11
IC Parallel.....	12
IC Parallel Configuration	12
Critical and Non-critical.....	12

Guide to connect the actuator to BusLink

Actuators with IC - Integrated Controllers from LINAK® can be configured via the BusLink Configuration Software. Please follow the three steps to connect your actuator to BusLink.



LA14



LA25



LA33



LA36



LA37

1 Start by downloading the free BusLink software here:



WWW.LINAK.COM/SEGMENTS/TECHLINE/TECH-TRENDS/IC-AND-BUS-ACTUATORS/

BusLink cable ordering numbers - include 1 USB2LIN cable and 1 Interface cable:

LA14/LA25 IC (blue interface): 0147999

LA36/LA37 Modbus (yellow interface): 0367998

LA33/LA36/LA37 IC (blue interface): 0367999

LA36 CAN bus (green interface): 0367997

LA14/LA25 CAN bus (green interface): 0147997

2 Cable connection

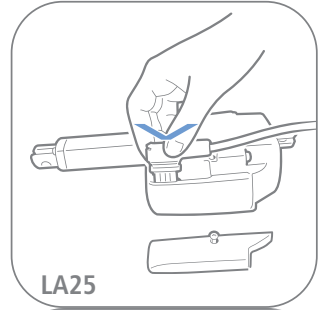
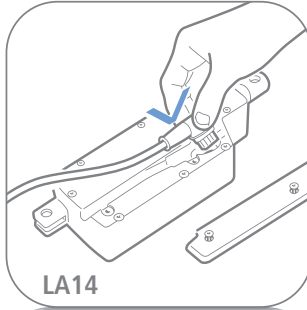
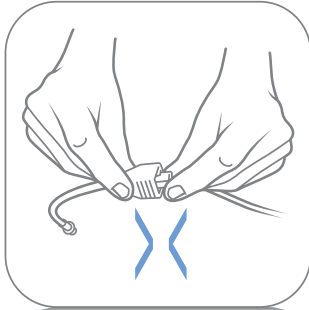

In order to connect your actuator to the PC tool you will need two separate cables:

1 USB2LIN cable.

1 interface cable.

Start by connecting the two cables.

Please note that the cables must be purchased separately from the actuator.

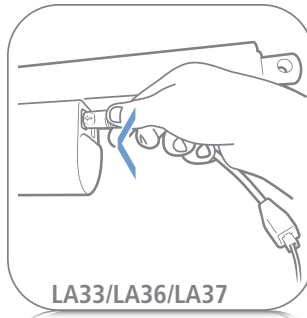

Before connecting the power supply:

Connect the interface cable to the actuator...

3 Power supply

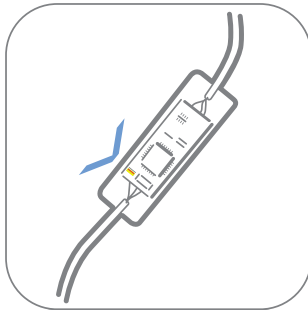
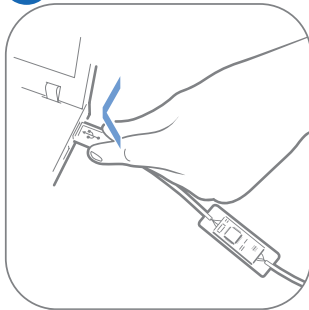

... and plug in the USB2LIN cable to your computer or laptop. Afterwards, please open the BusLink program on your computer.

The green diode on the USB2LIN will now flash, but please be aware that the BusLink program is still in a disconnected mode.

Finally, connect your power supply to the actuator.

A few seconds will pass before the connection to BusLink is established and the actuator is ready for configuration.



When changing the actuator's signal cable with the BusLink cable, it is important that this is done carefully in order to protect the plugs and pins. Please make sure that the plug is in the right place and fully pressed in before mounting the cable lid.

Configure the IC actuator with BusLink 2 software

The actuator can be controlled from within the software using the buttons at the bottom of the screen. These controls are available at all times. The "Run In/Out" buttons will run the actuator to the limits, real or virtual. The step controls will move the actuator in selectable increments. The "Run To" function will move the actuator to an arbitrary specified position. The actuator's current status is shown on the right. These values are actively recorded in a graph that will be explained later in this user guide.

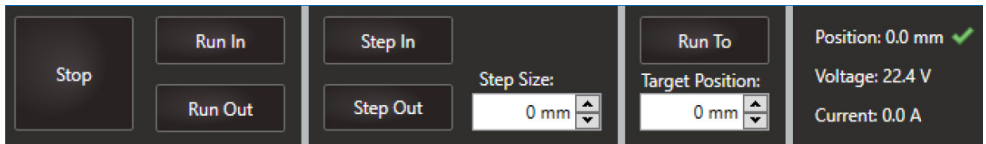

Configure:

Once connected, you will be able to click on one of three tabs in the top left. If you select CONFIGURE, this screen will appear:

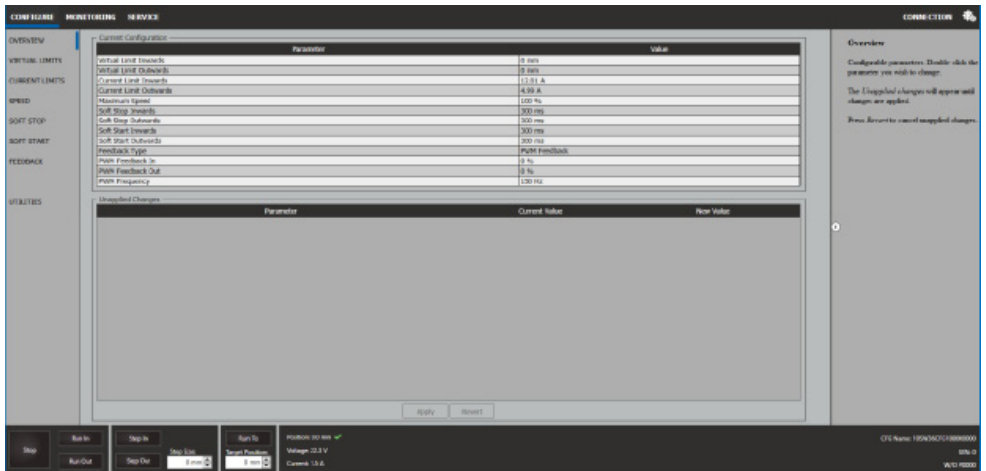

The overview will give you read-only information about the currently implemented parameters that can be edited. Each parameter can be modified by clicking on the menu item to the left. Any changes made will be shown in the "Unapplied Changes" box and will remain until you "Apply" the changes to the actuator.

Calibration

The IC platform uses hall effect sensors to determine the actuator's exact position along its stroke length. If once connected, the actuator's position status is displayed as "Not available", then the actuator must first be calibrated to use the full control functionality within the software. A calibration is required each time new parameters have been applied for the actuator's behavior. Calibration happens automatically whenever the actuator hits a limit switch, so it is not necessary to be connected to BUSLINK for this to occur.

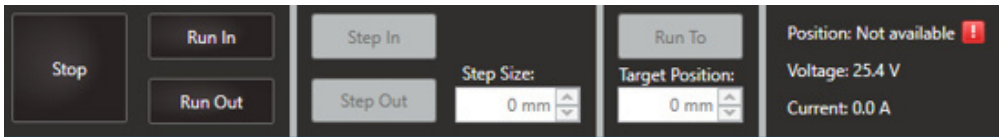

Initialize In/Out

To begin calibration, simply click on the "Service" tab at the top of the window, then select "Calibration" on the left menu.

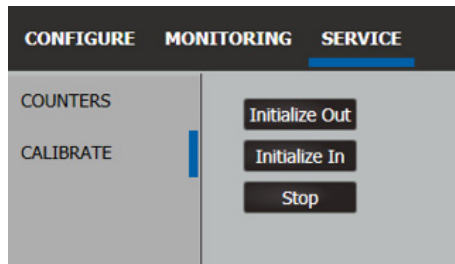

From here, determine where your actuator's current position is. If the actuator is fully extended, then select "Initialize In" to run the actuator to the inwards limit switch. If the actuator is fully retracted, then select "Initialize Out" to run the actuator to the outwards limit switch. If the actuator is somewhere in between fully extended and fully retracted, selecting either "Initialize In" or "Initialize Out" will successfully calibrate the system.

Once this process is complete, you'll find that the position is now available.

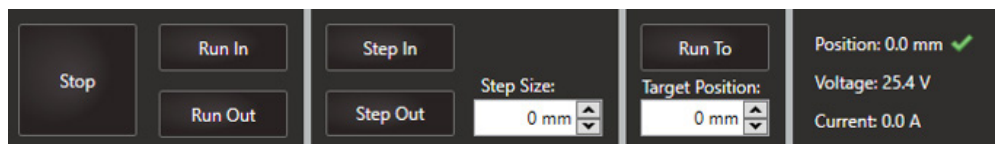

Controls

Virtual Limit:

A virtual end stop can be selected for either the inward or the outward direction. Only one virtual limit can be selected.

The screenshot displays two control panels for virtual limits. The left panel, titled "Virtual Limit Inwards", features a vertical slider with a white knob positioned at the bottom, labeled "0 mm". Below the slider is a numeric input field containing "54 mm" and a "Length" dropdown menu. The right panel, titled "Virtual Limit Outwards", has a similar slider with its knob at the bottom, labeled "0 mm", and a numeric input field containing "0" with a "Length" dropdown menu. At the bottom of the interface, there are two radio buttons: "Use Virtual Limit In" (which is selected) and "Use Virtual Limit Out".

Current Limit:

The current limit can be edited as a value or percentage for both directions. The maximum current will not exceed the maximum factory settings.

Note: If the actuator operating temperature reaches 0°C/32°F, the current limits are removed.

The screenshot shows two control panels for current limits. The left panel, titled "Current Limit Inwards", has a vertical slider with a white knob near the top, labeled "12.01 A". Below it is a numeric input field with "12.01 A" and a "Current" dropdown menu. The right panel, titled "Current Limit Outwards", has a vertical slider with a white knob near the bottom, labeled "4.99 A", and a numeric input field with "4.99 A" and a "Current" dropdown menu.

Controls

Speed:

The speed percentage can be adjusted as a motor voltage percentage. The lowest recommended speed is 60% to ensure that the actuator will push the rated load.

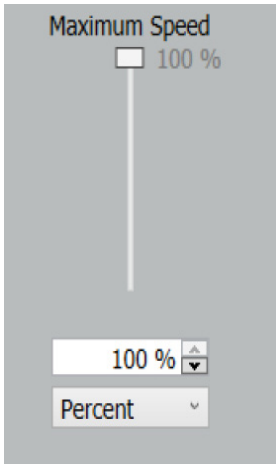

Maximum Speed

100 %

100 %

Percent

Soft Stop:

With a soft stop, you select a time-frame for the actuator to slow down to zero after the stop signal is applied. The time can be set between 0 (hard stop) and 30 sec, with the exception of: 0.1-299 ms. The reason for this, is that the actuator is unable to redirect/consume the accumulated energy in a 0.1-299 ms stop.

Soft Start:

The soft start is similar in function to the soft stop, but can be fully configured between 0-30 sec.

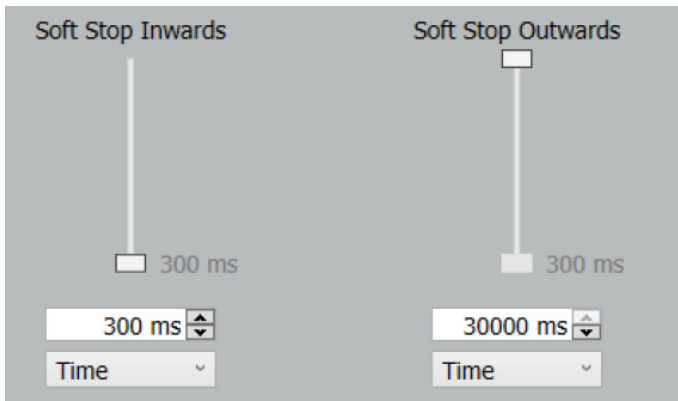

Soft Stop Inwards

300 ms

300 ms

Time

Soft Stop Outwards

30000 ms

30000 ms

Time

Feedback types

The IC Actuator can supply the user's control system with one of several types of feedback listed below, depending on model:

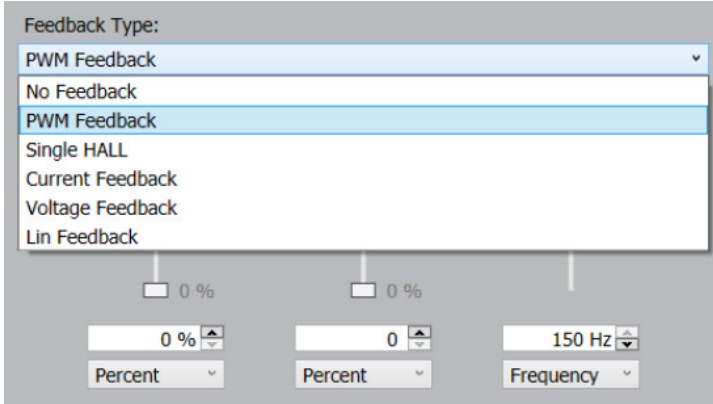

PWM:

The pulse width modulation (PWM) type is configurable with three parameters:

"PWM Feedback In" sets the percentage of the pulse for the IN "End of Stroke" (EOS) position.

The "PWM Feedback Out" sets the percentage pulse for the outermost position. Typical settings are 10% IN and 90% OUT. The feedback resolution is improved by having a wider pulse percentage range. The available base frequency range for PWM is 75-150 Hz.

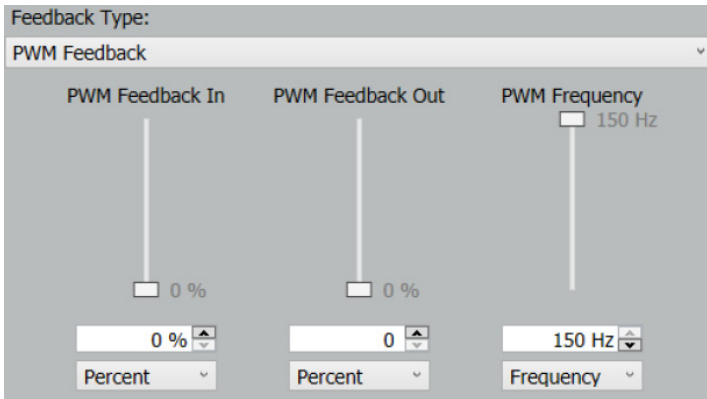

Single Hall:

Single hall can be selected but there are no changeable user modifiable parameters.

Feedback types

Current Feedback:

The position of the actuator can be correlated to current output. The available current range is 4-20 mA. The user can select values in the whole range but the highest resolution is achieved with the widest current range. The minimum setting is the IN EOS or virtual limit in position and the maximum is the OUT EOS or virtual limit out.

The screenshot shows a software interface for configuring feedback. At the top, a dropdown menu is set to "Current Feedback". Below this, there are two vertical sliders. The left slider is labeled "Minimum Feedback Current" and is positioned at the bottom, with a corresponding input field showing "4 mA" and a unit dropdown menu set to "Current". The right slider is labeled "Maximum Feedback Current" and is positioned at the top, with a corresponding input field showing "20 mA" and a unit dropdown menu set to "Current".

Voltage Feedback:

The position of the actuator can be correlated to a voltage output as well. The available voltage range is 0-10 V. The user can select any set of values in that range but the highest resolution is achieved with the widest voltage range. The minimum setting is the IN EOS or virtual limit position and the maximum is the OUT EOS or virtual limit out.

The screenshot shows a software interface for configuring feedback. At the top, a dropdown menu is set to "Voltage Feedback". Below this, there are two vertical sliders. The left slider is labeled "Minimum Feedback Voltage" and is positioned at the bottom, with a corresponding input field showing "0" and a unit dropdown menu set to "Voltage". The right slider is labeled "Maximum Feedback Voltage" and is positioned at the top, with a corresponding input field showing "10 V" and a unit dropdown menu set to "Voltage".

Feedback types

Monitoring:

The middle tab is a real-time graph showing current, position, and supply voltage. From here, you are able to change the scale by zooming and a snapshot as an image. The graph auto scales when taking a snapshot. You can save a snapshot as an image or as a dataset.

This snapshot shows the actuator moving from the OUT EOS position to the IN EOS position. If the position line does not show a movement, the position will be found when it reaches one of the end stops as the feedback is automatically initialised.

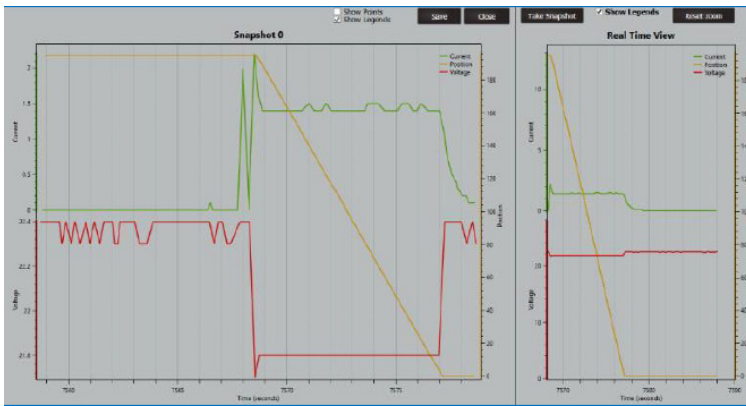

Service:

The service tab shows a detailed history into the life of the actuator.

This data can then be exported to a pdf file for review

Run/Stop	
Number of starts Inwards	256 times
Number of Starts Outwards	215 times
Reason for Last Unintended Stop	Under-voltage
Runtime	0h 54m 26s
Temperature	
Maximum FET Temperature Seen	77.3 °C
Maximum Actuator Temperature Seen	34.8 °C
Minimum Actuator Temperature Seen	13.5 °C
Number of Stops Due to Actuator Temperature	0 times
Actuator Temperature	30.2 °C
Counters	
Number of Stops Due to Hall Error	0 times
Number of EOS errors	0 times
Number of eos out	246 times
Number of EOS In	250 times
Voltage	
Number of Stops Due to Over-voltage	0 times
Number of Stops Due to Under-voltage	2 times
Current	
Total Current Usage	5316.3 As
Number of Customer Current Limit Overloads Out	9 times
Number of Customer Current Limit Overloads In	0 times
Maximum Current Seen	34.2 A
Number of Link Current Limit Overloads Out	0 times
Number of Link Current Limit Overloads In	0 times

Export to PDF

IC Parallel

IC Parallel Configuration:



If you have ordered an IC Parallel actuator, the actuator connects to BusLink in the same way as IC Advanced. An additional "PARALLEL" option is displayed on the left sidebar on the CONFIGURE screen. When selected, you can change the number of actuators in the parallel system. This safety setting determines the number of actuators an IC Parallel system must include in order to operate.

Critical and Non-critical:

When you select a number of actuators for your system, the operation is considered "Critical". When connected, the actuators are looking for the correct number of online actuators. If one becomes unresponsive, the whole system will stop. If you want the actuators to run in parallel, but without the necessity of all units in the system being connected, select "0" (Non-Critical) for all actuators in the system. All actuators will run together, but functions will not be blocked if one or more units are disconnected/offline. The selections available are "0" (Non-Critical), then "2-8" (Critical).

Note: Feedback is not an option with IC Parallel.

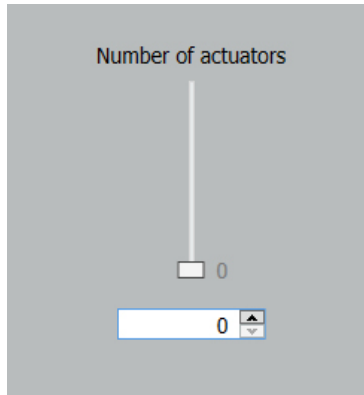
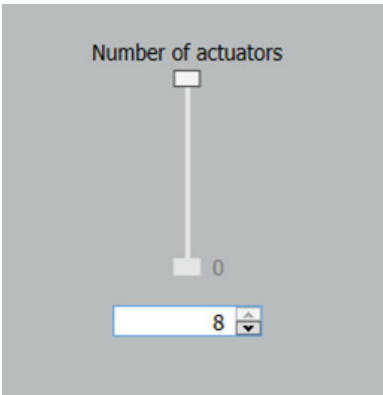

FACTORIES

China

LINAK (Shenzhen) Actuator Systems, Ltd.
Phone: +86 755 8610 6656
Phone: +86 755 8610 6990
www.linak.cn

Denmark - Headquarters

LINAK A/S
Phone: +45 73 15 15 15
Fax: +45 74 45 80 48
Fax (Sales): +45 73 15 16 13
www.linak.com

Slovakia

LINAK Slovakia s.r.o.
Phone: +421 51 7563 444
www.linak.sk

Thailand

LINAK APAC Ltd.
Phone: +66 33 265 400
www.linak.com

USA

LINAK U.S. Inc.
Americas Headquarters
Phone: +1 502 253 5595
Fax: +1 502 253 5596
www.linak-us.com
www.linak-latinamerica.com

SUBSIDIARIES

Australia

LINAK Australia Pty. Ltd
Phone: +61 3 8796 9777
Fax: +61 3 8796 9778
www.linak.com.au

Austria

LINAK Repräsentanz - Österreich (Wien)
Phone: +43 (1) 890 7446
Fax: +43 (1) 890 744615
www.linak.at - www.linak.hu

Belgium

LINAK Actuator-Systems NV/SA
(Belgium & Luxembourg)
Phone: +32 (0)9 230 01 09
www.linak.be - www.fr.linak.be

Brazil

LINAK Do Brasil Comércio De Atuadores Ltda.
Phone: +55 (11) 2832 7070
Fax: +55 (11) 2832 7060
www.linak.com.br

Canada

LINAK Canada Inc.
Phone: +1 502 253 5595
Fax: +1 416 255 7720
www.linak-us.com

Czech Republic

LINAK C&S s.r.o.
Phone: +42 058 174 1814
Fax: +42 058 170 2452
www.linak.cz - www.linak.sk

Denmark - International

LINAK International
Phone: +45 73 15 15 15
www.linak.com

Denmark - Sales

LINAK DANMARK A/S
Phone: +45 86 80 36 11
Fax: +45 86 82 90 51
www.linak.dk

Finland

LINAK OY
Phone: +358 10 841 8700
www.linak.fi

France

LINAK FRANCE E.U.R.L
Phone: +33 (0) 2 41 36 34 34
Fax: +33 (0) 2 41 36 35 00
www.linak.fr

Germany

LINAK GmbH
Phone: +49 6043 9655 0
Fax: +49 6043 9655 60
www.linak.de

India

LINAK A/S India Liaison Office
Phone: +91 120 4531797
Fax: +91 120 4786428
www.linak.in

Ireland

LINAK UK Limited (Ireland)
Phone: +44 (0)121 544 2211
Fax: +44 (0)121 544 2552
+44 (0)796 855 1606 (UK Mobile)
+35 387 634 6554
(Republic of Ireland Mobile)
www.linak.co.uk

Italy

LINAK ITALIA S.r.l.
Phone: +39 02 48 46 33 66
Fax: +39 02 48 46 82 52
www.linak.it

Japan

LINAK K.K.
Phone: 81-45-533-0802
Fax: 81-45-533-0803
www.linak.jp

Malaysia

LINAK Actuators Sdn. Bhd.
Phone: +60 4 210 6500
Fax: +60 4 226 8901
www.linak.my

Netherlands

LINAK Actuator-Systems B.V.
Phone: +31 76 5 42 44 40
www.linak.nl

New Zealand

LINAK New Zealand Ltd
Phone: +64 9580 2071
Fax: +64 9580 2072
www.linak.com.au

Norway

LINAK Norge AS
Phone: +47 32 82 90 90
www.linak.no

Poland

LINAK Polska
LINAK Danmark A/S (Spółka Akcyjna)
Phone: +48 22 295 09 70 /
+48 22 295 09 71
www.linak.pl

Republic of Korea

LINAK Korea Ltd.
Phone: +82 2 6231 1515
Fax: +82 2 6231 1516
www.linak.kr

Russia

LINAK LLC
Phone: +7 495 780 3161
Fax: +7 495 687 1426
www.linak.ru

Spain

LINAK Actuadores, S.L.u
Phone: +34 93 588 27 77
Fax: +34 93 588 27 85
www.linak.es

Sweden

LINAK Scandinavia AB
Phone: +46 8 732 20 00
Fax: +46 8 732 20 50
www.linak.se

Switzerland

LINAK AG
Phone: +41 43 388 31 88
Fax: +41 43 388 31 87
www.linak.ch - www.fr.linak.ch
www.it.linak.ch

Taiwan

LINAK (Shenzhen) Actuator systems Ltd.
Taiwan Representative office
Phone: +886 2 272 90068
Fax: +886 2 272 90096
www.linak.tw

Turkey

LINAK İth. İhr. San. ve Tic. A.Ş.
Phone: +90 312 4726338
Fax: +90 312 4726635
www.linak.com.tr

United Kingdom

LINAK UK Limited
Phone: +44 (0)121 544 2211
Fax: +44 (0)121 544 2552
www.linak.co.uk

DISTRIBUTORS

Argentina

NOVOTEC ARGENTINA SRL
Phone: 011-4303-8989/8900
Fax: 011-4032-0184
www.novotecargentina.com

Colombia

MEM Ltda
Phone: +[57] (1) 334-7666
Fax: +[57] (1) 282-1684
www.mem.net.co

India

Mechatronics Control Equipments
India Pvt Ltd
Phone: +91-44-28558484, 85
www.mechatronicscontrol.com

Indonesia

PT. HIMALAYA EVEREST JAYA
Phone: +6 221 544 8956,
+6 221 544 8965
Fax: +6 221 619 1925
Fax (Sales): +6 221 619 4658
www.hej.co.id

Iraq

Scan Medical Tech
Phone: +964 770 470 2202

Israel

NetivTech LTD
Phone: +972 55-2266-535
Fax: +972 2-9900-560
www.netivtech.com

Kingdom of Bahrain

Mechatronics Industrial Equipments
Phone: +973 17280059
Fax: +973 17910045
www.mechatronicsbh.com

Qatar

Mechatronics Industrial Equipments
Phone: +974 44581155
Fax: +974 44689135
www.mechatronicsqatar.com

Russia

OOD FAM
Phone: +7 812 3319333
Fax: +7 812 3271454
www.fam-drive.ru

Singapore

Servo Dynamics Pte Ltd
Phone: +65 6844 0288
Fax (Sales): +65 6844 0070

South Africa

Industrial Specialised Applications CC
Phone: +27 011 466 0346
www.isaza.co.za

United Arab Emirates

Mechatronics Industrial Equipments LLC
Phone: +971 4 267 4311
Fax: +971 4 267 4312
www.mechatronics.ae

LINAK® accepts no responsibility for possible errors or inaccuracies in catalogues, brochures, and other material. LINAK reserves the right to change its products without prior notice. LINAK cannot guarantee product availability and reserves the right to discontinue the sale of any product. The user is responsible for determining the suitability of LINAK products for a specific application. All sales are subject to the 'Standard Terms of Sale and Delivery', available on LINAK websites.

LINAK and the LINAK logotype are registered trademarks of LINAK A/S. All rights reserved.

LINAK® 

WE IMPROVE YOUR LIFE