



CANopen User manual v1.4

Contents

Preface	3
LINAK® application policy	4
About LINAK® CANbus actuators.....	5
Summary	5
Functional overview	6
Command details	7
Run in/out	7
Position	7
Maximum current in/out.....	7
Speed control.....	8
Running condition.....	9
Starting procedures	10
Process Data Objects (POD).....	11
Command details	11
Feedback status details	12
Service Data Objects (SDO).....	13
Internal monitoring	16
Current limits and measurements	16
Voltage.....	17
Temperature	17
H-bridge	17
Parameters.....	17
Environmental data and tests	18
Operational environment.....	18
Supply voltage	18
Power loss	18
Over voltage	18
EMC	19
BusLink service interface.....	20
Installing LINAK® CANopen actuators.....	21
Introduction	21
Connections.....	21
Electrical installation	22
Physical specifications	22
Power supply	22
Electronic Datasheet	22
Connection diagram.....	23
Termination	23

Preface

Dear User,

We are delighted that you have chosen a product from LINAK®.

LINAK systems are high-tech products based on many years of experience in the manufacture and development of actuators, electric control boxes, controls, and chargers.

This user manual does not address the end-user, but is intended as a source of information for the manufacturer of the equipment or system only, and it will tell you how to install, use and maintain your LINAK electronics. It is the responsibility of the manufacturer of the end-use product to provide a User Manual where relevant safety information from this manual is passed on to the end-user.

We are confident that your LINAK product/system will give you many years of hassle-free operation. Before our products leave the factory they undergo full function and quality testing. If you should experience any problem with your LINAK product/system please contact your local supplier. LINAK subsidiaries and some distributors have authorised service centres, which are always ready to help you.

LINAK provides warranty on all LINAK products. The warranty, however, is subject to correct use in accordance with the specifications, maintenance being done correctly and any repairs being carried out at a service centre, which is authorised to repair LINAK products.

Changes in installation and use of LINAK products/systems can affect their operation and durability. The products are not to be opened by unauthorised personnel.

This User Manual has been written based on our present technical knowledge. We are constantly striving to update both our products and the associated information we therefore reserve the right to carry out technical modifications without prior notice.

This user manual refers to the CANopen software version: SW01050007V3-1

Certified by CAN in Automation CiA:

Certificate # CiA202006-301V42/303-0243

Vendor ID 00 00 04 AA

LINAK A/S

LINAK® application policy

The purpose of the application policy is to define areas of responsibilities in relation to applying a LINAK product defined as hardware, software, technical advice, etc. related to an existing or a new customer application.

LINAK products as defined above are applicable for a wide range of applications within Medical, Furniture, Desk, and Industry areas. Yet, LINAK cannot know all the conditions under which LINAK products will be installed, used, and operated, as each individual application is unique.

The suitability and functionality of the LINAK product and its performance under varying conditions (application, vibration, load, humidity, temperature, frequency, etc.) can only be verified by testing, and shall ultimately be the responsibility of the LINAK customer using any LINAK product.

LINAK shall be responsible solely that LINAK products comply with the specifications set out by LINAK and it shall be the responsibility of the LINAK customer to ensure that the specific LINAK product can be used for the application in question.

Summary

This document describes the capabilities of LINAK TECHLINE® CANopen components and the requirements for controlling these. It specifies the technologies involved, the environmental data specification and the functional description.

LINAK TECHLINE CANopen actuators are primarily designed with focus on industrial automation.

The communication protocol relies on the CiA 301 standard. The contents of this document assume that the reader is familiar with the CiA 301 standard.

In addition to full position control, the CANopen actuator can provide feedback information about the piston position, service data and full diagnostics. It also provides system identification data and actual current at runtime.

Functional overview

The LINAK® TECHLINE® CANopen offers a communication profile defined in CiA DS 301 V 4.0.2. This includes a command set for controlling the actuator in addition to feedback status.

- Process Data Objects PDO
- Service Data Objects SDO
- Objects with special functions for synchronization, error alert and response.
 - Synchronization object (SYNC)
 - Emergency object (EMCY)
- Network Management Objects (NMT) for initialization, error monitoring and status monitoring of the device.
 - NMT commands
 - Boot-up messages
 - Heartbeat messages

Command details

Run in/out

In and out movement is performed by sending the proper identifier while the actuator is in CANopen mode. In Service mode, movement is achieved by using the LINAK® BusLink PC software or by applying the proper signals to the Manual run wires. Using manual run, a start-up delay of up to 150 ms must be expected due to safety measures.

Position

Max/min. position: Stroke length

Level setting steps: 0.1 mm

Load, ramping up and down and specific actuator type (spindle/gear box) should be taken into account in regard to accuracy.

The Position SetPoint can be set dynamically.

If the new SetPoint involves a change in running direction, the ramps will follow the pre-set ramp time.

Maximum current in/out

Applying a current limit will induce a degree of mechanical overload protection to the installation.

Max. current limit: Fixed limit*

Level setting steps: 0.25 A

*The custom current limit setting cannot overrule the fixed factory setting which insures partially protection of the electronics and mechanics. See "Internal monitoring" on page 16 for details.

Speed control

The speed is controlled using Pulse Width Modulation (PWM).

Min. duty cycle: 0 %

Max. duty cycle: 100 %

Level setting steps: 0.5 %

Closed loop speed control will ensure a more accurate speed. In order to obtain this, the maximum speed is reduced to approximately 80%. The actual speed will be influenced by the gear and spindle size in the actuator.

The speed setting can be changed dynamically at run time.

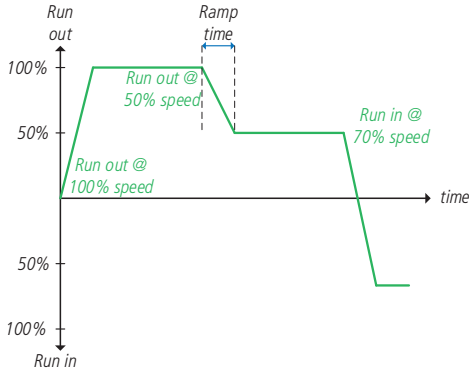

Figure 1. Speed control Graphics

Running conditions

In order to run the actuator please take the following into account.

- If the Heartbeat is not present the actuator will not accept any PDO commands.
- Commands must be resend if communication is interrupted or the Heartbeat signal is missing.
- RUN IN and RUN OUT commands cannot be issued if errors are present (error code != 0).
- Heartbeat status can be read with status bit 5.
- Upon entering OPERATIONAL actuator requires a STOP or CLEAR ERROR command.

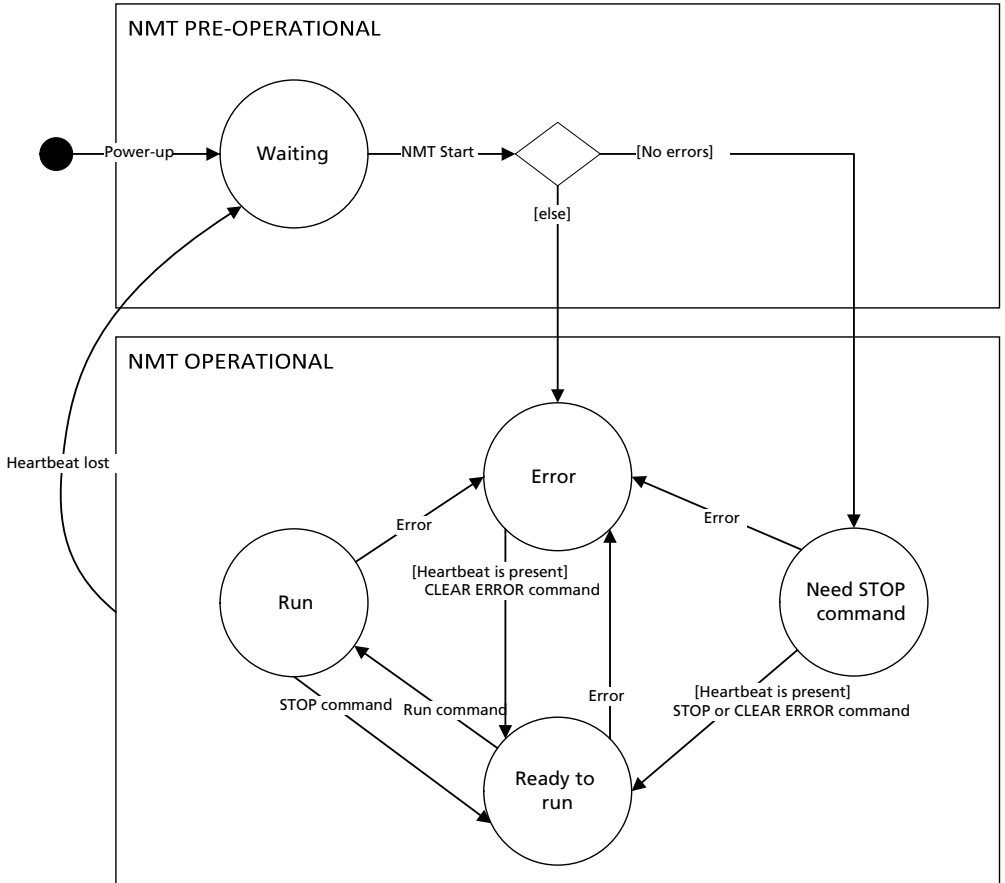

Figure 2. Running conditions

Starting procedures

Follow the example below to complete the startup procedures necessary for successful communication. The CAN address in this example is in 32 (0X20).

CAN ID (hex)	Data (hex)								Description	
	0	1	2	3	4	5	6	7		
701	05								Master Heartbeat. Sent every 100ms	Startup Procedures
720	00								Actuator boot-up	
620	23	16	10	01	C8	00	01	00	Receive Service Data Objects SDO	
5A0	60	16	10	01	00	00	00	00	Actuator response	
000	01	20							Network management NMT Start	
1A0	00	00	00	C1	01	00	00	C0	Transmit Process Data Object TPDO1. STOP command needed	
220	03	FB	FB	FB	FB	FB	00	00	Stop command	
1A0	00	00	00	C1	00	00	00	C0	Transmit PDO1. Actuator at EOS in [0 mm]	Running examples
220	01	FB	FB	FB	FB	FB	00	00	Run out command	
1A0	A1	00	06	C8	00	31	00	C0	Transmit PDO1. Actuator is running out [2.6 mm]	
1A0	F7	01	00	C2	00	00	00	C0	Transmit PDO1. Actuator reached EOS out [50.3 mm]	
220	02	FB	FB	FB	FB	FB	00	00	Run in command	
1A0	60	00	06	D0	00	32	00	C0	Transmit PDO1. Actuator is running in [9.6 mm]	
1A0	00	00	00	C1	00	00	00	C0	Transmit PDO1. Actuator reached EOS in [0 mm]	

Master

Actuator

Figure 3. Starting procedures

To use another CAN address than 32 (0X20) please redefine the CAN ID to suit the need.

Process Data Objects (PDO)

RPDO1 is mapped to 0x2000

TPDO1 is mapped to 0x2001

Command details

Index	Subindex	Command	Data type	Details	Description	Unit
0x2000	1	Position	UINT16	0-64255 64256 64257 64258 64259 64260 64261 64262-65535	Run to position Clear ErrorCode register (see 0x1001) Command run actuator out Command run actuator in Command stop actuator* Command run to actuator out, Recovery mode Command run to actuator in, Recovery mode Invalid value, actuator will not run	0.1 mm/bit
	2	Current	UINT8	0-250 251 252-255	Maximum current limit Use default current value Invalid value, actuator will not run	0.25 A/bit
	3	Speed	UINT8	0-200 201-250 251 252-255	Speed to use Use 100% speed Actuator default speed value Invalid value, actuator will not run	0.5%/bit
	4	Soft start	UINT8	0-250 251 252-255	Start ramping time (ms) Use default soft start value Invalid value, actuator will not run	0.05 s/bit
	5	Soft stop	UINT8	0-250 251 252-255	Stop ramping time (ms) Use default soft stop value Invalid value, actuator will not run	0.05s/bit

Table 1. Command details.

Feedback status details

Index	Subindex	Command	Data type	Details	Description	Unit
0x2001	1	Position	UINT16	0-64255 64256-65023 65024 65025-65535	Position of actuator piston Reserved Position lost Reserved	0.1 mm/bit
	2	Current	UINT8	0 1-250 251-253 254 255	Not running Measured motor current Reserved Fault in current measurement circuit Reserved	0.25 A/bit
	3	Status flags	UINT8	b0 b1 b2 b3 b4 b5 b6-b7	EOS in EOS out Over current Running out Running in CANopen heartbeat needed Reserved	8bit independent status bit- indicators
	4	Error codes	UINT8	0 1 2 3 4 5 6 7 8	No error Need stop command Hall error Over voltage Under voltage Failed to maintain heartbeat EOS error Temperature error Heart beat error (internal)	8bit error code indicating the currently active error of highest priority
				9 10 254 255	SMPS error (internal) Current measurement (internal) Internal fault (not specified) External fault (not specified)	
	5	Speed	UINT16	0-4015 4016-65535	Speed of actuator piston Reserved	0.1mm/s/bit
	6	Input state	UINT8	b0-b1 b2-b3 b4-b5 b6-b7	Input 1 level Input 2 level Input 3 level Reserved (always1)	25% /bit

Table 2. Feedback status details. .

Service Data Objects (SDO)

Index	Subindex	Data type	Access	Name	Details	Unit	Description
0x1000				Device type		see CiA 301 7.5.2.1	
0x1001				Error register		see CiA 301 7.5.2.2	
0x1005				CO B- IDSYNC		see CiA 301 7.5.2.5	Default value is used (0x80)
0x1009				Manufacturer hardware version		see CiA 301 7.5.2.9	PCBA name
0x1014				CO B- IDEMCY		see CiA3017.5.2.17	Default value is used (0x80 + Node- ID)
0x1015				Inhibit time EMCY		see CiA 301 7.5.2.18	Default value is used (0)
0x1016				Consumer heartbeat time		see CiA 301 7.5.2.19	Only one consumer heartbeat at time is supported
0x1017				Producer heartbeat time		see CiA 301 7.5.2.20	
0x1018				Identity object		see CiA 301 7.5.2.21	
	1	UINT32	R	Vendor ID	0x000004AA		LINAK
	2	UINT32	R	Producer code			Software number (e.g. 1050000)
	2	UINT32	R	Revision number			CANopen interface revision
	4	UINT32	R	Serial number			Same as UIN
0x1200				SDO server parameter		see CiA 301 7.5.2.33	
	1						Default value is used (0x600+ Node-ID)
	2						Default value is used (0x580 + Node-ID)
0x1400				RPDO communication parameter		see CiA 301 7.5.2.35	
	1						Default value is used (0x200 + Node-ID)
	2						event-driven (manufacturer-specific)
0x1600				RPDO mapping parameter		see CiA 301 7.5.2.36	1 to 1 mapping of 0x2000 (Actuator Command)
0x1800				TPDO communication parameter		see CiA 301 7.5.2.37	
	1	UINT32					Default value is used (0x180+ Node-ID)
	2	UINT8		Transmission Character			event-driven (manufacturer-specific)
	5	UINT16		Event timer	250	1ms/bit	
0x1A00				TPDO mapping parameter		see CiA 301 7.5.2.38	1 to 1 mapping of 0x2001 (Actuator Status)

Table 3. Service Data Objects.

Index	Subindex	Data type	Access	Name	Details	Unit	Description
OX4000		Record		Diagnostic			Actuator diagnostic parameters
	0	UINT8	R	Highest sub-index supported			
	1	UINT8	RW	Current limit out		0.25A/bit	
	2	UINT8	RW	Current limit in		0.25A/bit	
	3	UINT16	RW	Soft start time out		1ms/bit	
	4	UINT16	RW	Soft start time in		1ms/bit	
	5	UINT16	RW	Soft stop time out		1ms/bit	
	6	UINT16	RW	Soft stop in		1ms/bit	
	7	UINT8	RW	Maximum speed	0-200 201-255	0.5%/bit 100%	
	8	UINT16	RW	Virtual EOS out position		0.1mm/bit	
	9	UINT16	RW	Virtual EOS in position		0.1mm/bit	
	10	UINT32	R	UIN		8 number format	
	11	UINT32	R	SW variant [x]		SWxxxxxxVy-x	Software number (e.g. 105000)
	12	UINT32	R	SW version Major [y]			
	13	UINT32	R	SW version Minor [z]			
	14	UINT32	R	Config production order number			
	15	UINT32	R	Production date		yyyymmdd	
	16	UINT8	R	Maximum current seen		0.25A/bit	
	17	UINT8	R	Maximum FET temperature seen		1 °C/bit-40	
	18	UINT32	R	Maximum ambient temperature seen		1 °C/bit-40	
	19	UINT8	R	Minimum ambient temperature seen		1 °C/bit-40	
	20	UINT32	R	Current usage		1As/bit	
	21	UINT32	R	Runtime		1s/bit	
	22	UINT8	R	Number of stops due to overvoltage			
	23	UINT8	R	Number of stops due to FET over temperature			
	24	UINT8	R	Number of stops due to ambient over temperature			
	25	UINT8	R	Number of stops due to low voltage			
	26	UINT	R	Number of stops due to hall errors			
	27	UINT8	R	Number of stops due to EOS switch errors			
	28	UINT8	R	LINAK current overload out stops			
	29	UINT8	R	LINAK current overload in stops			
30	UINT8	R	Resettable Custom current overload out stops				
31	UINT8	R	Resettable Custom current overload in stops				

32	UINT16	R	Communication errors			
33	UINT16	R	Number of EOS out			
34	UINT16	R	Number of EOS in			
35	UINT32	R	Number of starts out			
36	UINT32	R	Number of starts in			
37	UINT32	R	Total piston distance		5 m/bit	
38	UINT16	R	Last stop reason id 0			Stop reason id
39	UINT8	R	Last stop count id 0			Number of consecutive stop reasons of the same type
40	UINT32	R	Last stop powered time id 0			Powered time when the last stop occurred
41	UINT16	R	Last stop reason id 1			Stop reason id
42	UINT8	R	Last stop count id 1			Number of consecutive stop reason of the same type
43	UINT32	R	Last stop powered time id 1			Powered time when the last stop occurred
44	UINT16	R	Last stop reason id 2			Stop reason id
45	UINT8	R	Last stop count id 2			Number of consecutive stop reason of the same type
46	UINT32	R	Last stop powered time id 2			Powered time when the last stop occurred
47	UINT16	R	Last stop reason id 3			Stop reason id
48	UINT8	R	Last stop count id 3			Number of consecutive stop reason of the same type
49	UINT32	R	Last stop powered time id 3			Powered time when the last stop occurred
50	UINT16	R	Last stop reason id 4			Stop reason id
51	UINT8	R	Last stop count id 4			Number of consecutive stop reason occurred
52	UINT32	R	Last stop powered time id 4			Powered time when the last stop occurred
53	UINT32	R	Total corrected distance			

Table 4. Service Data Objects.

Use the CiA® 305, Layer Setting Services (LSS) for CANopen node-ID assignment and changing CANopen bitrate.

Internal monitoring

A number of parameters are monitored during operation to prevent overloading the electronics and to minimise the risk of mechanical damage.

Current limits and measurements

The principle behind the current measurement is an 'above limit' and 'below limit' accumulating counter. When the Timeout counter reaches a specific value the current cut-off goes into effect. The timeout value is pre-set at 200 to 500ms depending on actuator type.

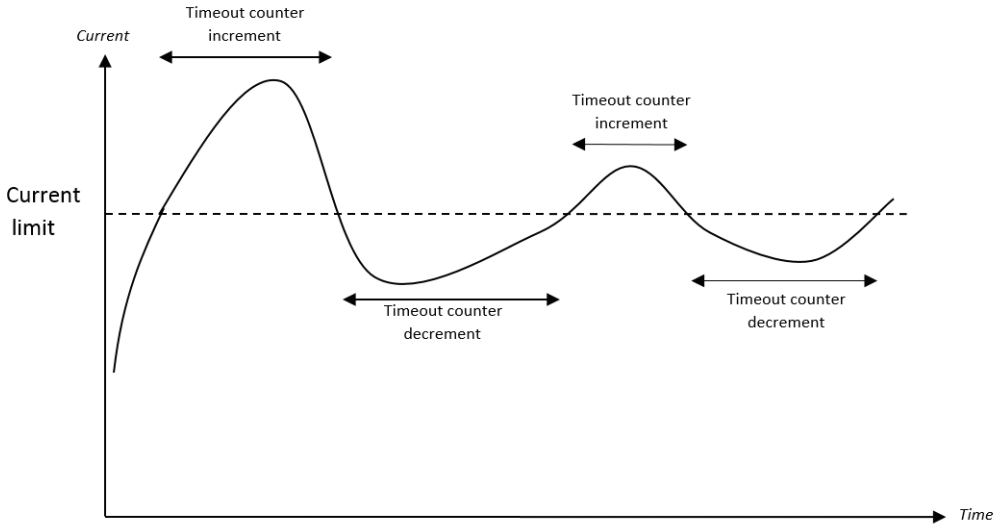

Figure 3. Dynamic current limit principle.

In case of current limit activation (Timeout counter max is reached), the actuator will stop and an over current error is triggered. The error is cleared when the actuator is activated in the opposite direction or by issuing a Clear error command.

Custom over current limit can only be lower than or equal to the fixed factory setting.

Voltage

The supply voltage level is monitored in order to maintain a safe operation and to protect the circuitry.

Temperature

Two temperature monitoring circuits are in place to measure the absolute temperature of the board and the centre temperature of the H-bridge.

H-bridge

The H-bridge conditions are monitored at all times. Several conditions are required in order to run.

Among these are:

- Correct voltage supplies
- Heartbeat safety signal
- Correct temperatures
- No errors

Parameters

In addition to the immediate monitoring, a number of parameters are saved for long-term evaluation.

These include:

- Number of starts in either direction
- Reason for last stop
- Total running time
- Under and over voltage
- Maximum current
- Number of current overloads in either direction

These parameters will help the engineer sort out existing issues. Considering a combination of parameter values, the lifetime load can indicate a potential failure before it happens and thereby prevent downtime.

Environmental data and tests

The CANbus actuators fulfil the environmental requirements as defined:

Operational environment

Ambient temperature: -30°C to 65°C (full performance only from +5°C to 40°C)

Relative humidity: 30% to 80% @ 30°C

Pressure: 700hPa to 1060hPa

Storage environment

Ambient temperature: -55°C to 105°C

Relative humidity: 30% to 80% @ 30°C

Pressure: 700hPa to 1060hPa

Supply voltage

The actuator will be available in three supply voltage ranges, 12 VDC, 24 VDC, and 48 VDC. The accepted supply voltage range is specified according to ISO16750-2012.

Supply voltage	V _{MIN}	V _{TYP}	V _{MAX}	Reference	Note
12 V	10.5 V	12 V	16 V	ISO 16750-2:2012 - Code D	Motor running
	6 V	12 V	39 V	ISO 16750-2:2012 - Code A	Motor not running CAN communication possible
24 V	18 V	24 V	32 V	ISO 16750-2:2012 - Code H	Motor running
	10 V	24 V	39 V	ISO 16750-2:2012 - Code E	Motor not running CAN communication possible
48 V	36 V	48 V	58 V	no reference	Motor running
	10 V	48 V	60 V	no reference	Motor not running CAN communication possible

Table 4. Voltage supply levels.

Power loss

In case of power loss, the actuator position and other important data is saved by the on-board microcontroller.

Over voltage

If the voltage rises above the set limit, the system will enter overvoltage protection mode and shut down.

EMC

The Electromagnetic Compatibility tests performed on the LINAK® CANopen actuator comply with the TECHLINE® Electrical Test Specification. The scope of tests is verified and accredited by DELTA A/S test laboratory.

Norm/Standard	Test description
ISO 16750-2:2012	Supply voltage range
	Overvoltage
	Superimposed alternating voltage
	Slow lowering and raising the voltage supply
	Momentary drop in supply voltage
	Reset behaviour for voltage drop
	Reversed voltage
	Ground reference and supply offset
	Open circuit test
	Short circuit protection
	Load dump – Test pulse 5a
	Load dump test pulse 5b
ISO 7637-2:2011	Test pulse 1
	Test pulse 2a
	Test pulse 2b
	Test pulse 3a
	Test pulse 3b
ISO 16750-2:2012	Test pulse 4
ISO 7637-2:2011	Voltage transient emission test on power supply lines
ISO 7637-3:2007	Electric transient transmission by cap. and inductive coupling
CISPR 25 IEC:2008	Conducted disturbance voltage measurement
	Radiated emission – ALSE method
CISPR 16-1-2:2010	Conducted emission
CISPR 16-2-3:2010	Radiated emission
ISO 10605 2 nd Ed.	ESD immunity
IEC 61000-4-2 2 nd Ed.	ESD immunity
ISO 11452-1:2005, ISO 11452-2:2004, ISO 11452-4:2011, ISO 11452-5:2002	Interference immunity
IEC 61000-4-3:2006	Interference fields immunity test
IEC 61000-4-8:2010	Power frequency magnetic field
IEC 61000-4-4:2004	Burst transients
IEC 61000-4-5:2006	Surge transients

Table 5. LINAK TECHLINE EMC test overview.

BusLink service interface

The BusLink service interface offers a wide range of settings and status feedback options. Use the LINAK® USB2LIN cable and the LINAK BusLink PC software will gain access to:

BusLink settings

- Initialisation
- Current limit settings
- Soft start/stop timing

BusLink feedback

- Run time parameters
- Number of starts and stops
- Maximum current and temperature
- Error messages

The actuator can also be run manually using BusLink control interface. During normal CAN operation, BusLink manual run is disabled. The service interface is only intended to run with the BusLink PC software tool.



Figure 4. LINAK USB2LIN service cable.



Figure 5. LINAK adapter cable.

See the [BusLink Quick Guide](#) for details on how to connect to the specific actuator model.

The USB2LIN service cable and adapter cable suitable for CAN actuators can be ordered as	
USB2LIN adapter	USB2LINO6
LA14CAN/ LA25CAN Adapter	0965205-A
LA33CAN/ LA36CAN/ LA37Can Adapter	0968011-A

Installing LINAK® CANopen actuators

Introduction

This section will assist you in the installation of the LINAK CANopen actuator. Going through parameters and procedures necessary for a successful implementation.

- Connections
- Electrical installation
- Communication

Connections

The tables below define the wire connections to the LINAK TECHLINE CANopen actuators. The colours are consistent with all LINAK TECHLINE CANopen actuators. The pinning definition provided by CiA 303-1 for mini-fit connector do **not** comply with the definition below.

Single connector actuators

Power connector, 8-pin mini-fit connector

LINAK cable	Description
Brown	+ Power supply (12/24/48VDC)
Blue	- Power supply (GND)
Black	Manual run in
Red	Manual run out
White	Service interface GND
Purple	Service interface DATA
Yellow	CAN H
Green	CAN L

Table 6. Power and communication wire colour.

Dual connector actuators

Power connector, 6-pin mini-fit connector

LINAK cable	Description
Brown	+ Power supply (12/24/48VDC)
Blue	- Power supply (GND)

Table 7. Power wire colours.

Communication connector, 6-pin micro-fit connector

LINAK cable	Description
Black	Manual run in
Red	Manual run out
White	Service interface GND
Purple	Service interface
Yellow	CAN H
Green	CAN L

Table 8. Communication wire colours.

By default, cables are supplied with flying leads.

Electrical installation

Physical specifications

LINAK CANopen actuators provide a physical layer according to ISO 11898-2.

Speed	125, 250, 500 kbps
Max bus length	250 meters
Max stub length	11 meters
Accumulated stub length	55 meters
Max node count	127
Cable impedance	120 Ω ($\pm 10\%$)
Default CANopen node ID	32

Power supply

The power supply for the LINAK[®] CANbus actuator should be kept separate from the CANbus power supply, if such one exists.

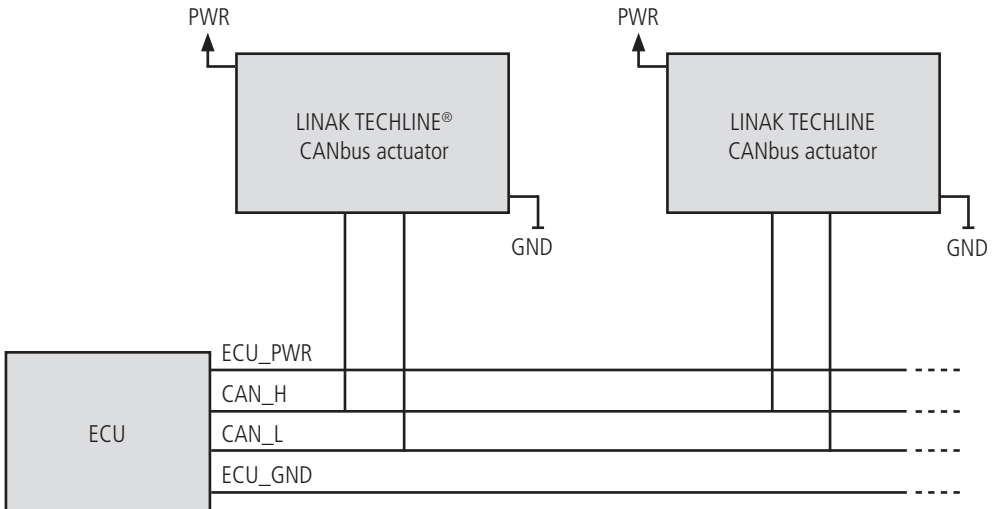

Figure 5. Power supply connection setup.

Electronic Datasheet

An *eds* file can be obtained by contacting Linak. The *eds* file complies with the CiA 306 standard.

Connection diagram

During the optional manual run mode, the actuator will continue to send status feedback on the CANbus. However, if other CAN devices are active on the network, manual run mode will be disengaged. The Service interface is also accessible during manual run mode.

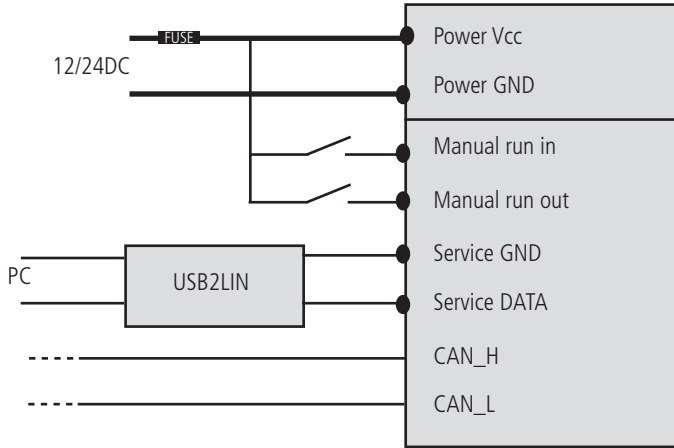

Figure 6. Connection pinout.

Termination

Termination resistors of 120 Ω should be connected according to figure 7. The actuator does not have internal termination.

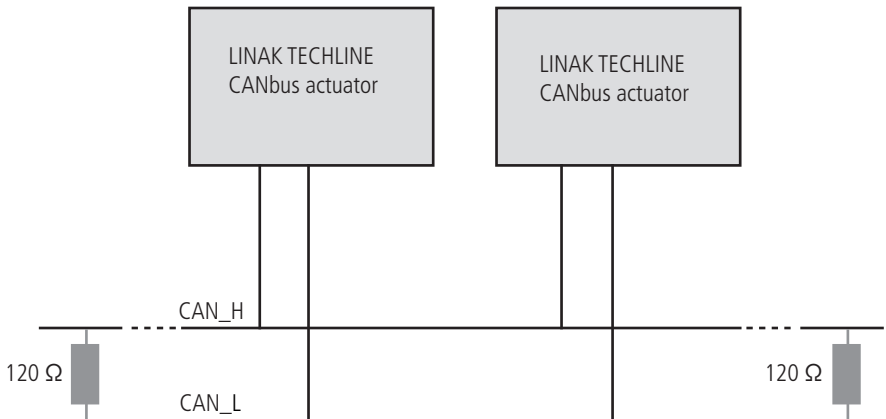

Figure 7. Termination connection diagram.

CANopen

certified by



Certificate # **CiA202006-301V42/303-0243**

Vendor ID **00 00 04 AA**

Manufacturer Linak A/S

Device LAXxCAN

Product code: 00100597
Object 1018h/02h

Revision number: 00010000
Object 1018h/03h

Hardware version: 10LAXXCA-A-0
Object 1009h

Software version: -
Object 100Ah

EDS LINAK_actuator.eds

File version: 1
EDS version: 4.0

File revision: 1

Nuremberg, 10.06.2020

Technical Manager **CAN in Automation GmbH**
Kontumazgarten 3
DE-90429 Nürnberg
Tel: +49-911-928819-0
Fax: +49-911-928819-79

CAN in Automation GmbH
Kontumazgarten 3
90429 Nuremberg
Germany
phone: +49-911-928819-0
fax: +49-911-928819-79



FACTORIES

China

LINAK (Shenzhen) Actuator Systems, Ltd.
Phone: +86 755 8610 6656
Phone: +86 755 8610 6990
www.linak.cn

Denmark - Headquarters

LINAK A/S
Phone: +45 73 15 15 15
Fax: +45 74 45 80 48
Fax (Sales): +45 73 15 16 13
www.linak.com

Slovakia

LINAK Slovakia s.r.o.
Phone: +421 51 7563 444
www.linak.sk

Thailand

LINAK APAC Ltd.
Phone: +66 33 265 400
www.linak.com

USA

LINAK U.S. Inc.
Americas Headquarters
Phone: +1 502 253 5595
Fax: +1 502 253 5596
www.linak-us.com
www.linak-latinamerica.com

SUBSIDIARIES

Australia

LINAK Australia Pty. Ltd
Phone: +61 3 8796 9777
Fax: +61 3 8796 9778
www.linak.com.au

Austria

LINAK Repräsentanz - Österreich (Wien)
Phone: +43 (1) 890 7446
Fax: +43 (1) 890 744615
www.linak.at - www.linak.hu

Belgium

LINAK Actuator-Systems NV/SA
(Belgium & Luxembourg)
Phone: +32 (0)9 230 01 09
www.linak.be - www.fr.linak.be

Brazil

LINAK Do Brasil Comércio De Atuadores Ltda.
Phone: +55 (11) 2832 7070
Fax: +55 (11) 2832 7060
www.linak.com.br

Canada

LINAK Canada Inc.
Phone: +1 502 253 5595
Fax: +1 416 255 7720
www.linak-us.com

Czech Republic

LINAK C&S s.r.o.
Phone: +42 058 174 1814
Fax: +42 058 170 2452
www.linak.cz - www.linak.sk

Denmark - International

LINAK - International
Phone: +45 73 15 15 15
www.linak.com

Denmark - Sales

LINAK DANMARK A/S
Phone: +45 86 80 36 11
Fax: +45 86 82 90 51
www.linak.dk

Finland

LINAK OY
Phone: +358 10 841 8700
www.linak.fi

France

LINAK FRANCE E.U.R.L.
Phone: +33 (0) 2 41 36 34 34
Fax: +33 (0) 2 41 36 35 00
www.linak.fr

Germany

LINAK GmbH
Phone: +49 6043 9655 0
Fax: +49 6043 9655 60
www.linak.de

India

LINAK A/S India Liaison Office
Phone: +91 120 4531797
Fax: +91 120 4786428
www.linak.in

Ireland

LINAK UK Limited (Ireland)
Phone: +44 (0)121 544 2211
Fax: +44 (0)121 544 2552
+44 (0)796 855 1606 (UK Mobile)
+35 387 634 6554
(Republic of Ireland Mobile)
www.linak.co.uk

Italy

LINAK ITALIA S.r.l.
Phone: +39 02 48 46 33 66
Fax: +39 02 48 46 82 52
www.linak.it

Japan

LINAK K.K.
Phone: 81-45-533-0802
Fax: 81-45-533-0803
www.linak.jp

Malaysia

LINAK Actuators Sdn. Bhd.
Phone: +60 4 210 6500
Fax: +60 4 226 8901
www.linak.my

Netherlands

LINAK Actuator-Systems B.V.
Phone: +31 76 5 42 44 40
www.linak.nl

New Zealand

LINAK New Zealand Ltd
Phone: +64 9580 2071
Fax: +64 9580 2072
www.linak.com.au

Norway

LINAK Norge AS
Phone: +47 32 82 90 90
www.linak.no

Poland

LINAK Polska
LINAK Danmark A/S (Spółka Akcyjna)
Phone: +48 22 295 09 70 /
+48 22 295 09 71
www.linak.pl

Republic of Korea

LINAK Korea Ltd.
Phone: +82 2 6231 1515
Fax: +82 2 6231 1516
www.linak.kr

Russia

LINAK LLC
Phone: +7 495 780 3161
Fax: +7 495 687 1426
www.linak.ru

Spain

LINAK Actuadores, S.L.U
Phone: +34 93 588 27 77
Fax: +34 93 588 27 85
www.linak.es

Sweden

LINAK Scandinavia AB
Phone: +46 8 732 20 00
Fax: +46 8 732 20 50
www.linak.se

Switzerland

LINAK AG
Phone: +41 43 388 31 88
Fax: +41 43 388 31 87
www.linak.ch - www.fr.linak.ch
www.it.linak.ch

Taiwan

LINAK (Shenzhen) Actuator systems Ltd.
Taiwan Representative office
Phone: +886 2 272 90068
Fax: +886 2 272 90096
www.linak.tw

Turkey

LINAK İth. İhr. San. ve Tic. A.Ş.
Phone: +90 312 4726338
Fax: +90 312 4726635
www.linak.com.tr

United Kingdom

LINAK UK Limited
Phone: +44 (0)121 544 2211
Fax: +44 (0)121 544 2552
www.linak.co.uk

DISTRIBUTORS

Argentina

NOVOTEC ARGENTINA SRL
Phone: 011-4303-8989/8900
Fax: 011-4032-0184
www.novotecargentina.com

Colombia

MEM Ltda
Phone: +[57] (1) 334-7666
Fax: +[57] (1) 282-1684
www.mem.net.co

India

Mechatronics Control Equipments
India Pvt Ltd
Phone: +91-44-28558484, 85
www.mechatronicscontrol.com

Indonesia

PT. HIMALAYA EVEREST JAYA
Phone: +6 221 544 8956,
+6 221 544 8965
Fax: +6 221 619 1925
Fax (Sales): +6 221 619 4658
www.hej.co.id

Iraq

Scan Medical Tech
Phone: +964 770 470 2202

Israel

NetivTech LTD
Phone: +972 55-2266-535
Fax: +972 2-9900-560
www.netivtech.com

Kingdom of Bahrain

Mechatronics Industrial Equipments
Phone: +973 17280059
Fax: +973 17910045
www.mechatronicsbh.com

Qatar

Mechatronics Industrial Equipments
Phone: +974 44581155
Fax: +974 44689135
www.mechatronicsqatar.com

Russia

OOO FAM
Phone: +7 812 3319333
Fax: +7 812 3271454
www.fam-drive.ru

Singapore

Servo Dynamics Pte Ltd
Phone: +65 6844 0288
Fax (Sales): +65 6844 0070

South Africa

Industrial Specialised Applications CC
Phone: +27 011 466 0346
www.isaza.co.za

United Arab Emirates

Mechatronics Industrial Equipments LLC
Phone: +971 4 267 4311
Fax: +971 4 267 4312
www.mechatronics.ae

LINAK® accepts no responsibility for possible errors or inaccuracies in catalogues, brochures, and other material. LINAK reserves the right to change its products without prior notice. LINAK cannot guarantee product availability and reserves the right to discontinue the sale of any product. The user is responsible for determining the suitability of LINAK products for a specific application. All sales are subject to the 'Standard Terms of Sale and Delivery', available on LINAK websites.

LINAK and the LINAK logotype are registered trademarks of LINAK A/S. All rights reserved.

LINAK® 
WE IMPROVE YOUR LIFE