

LC3 IC

User Manual

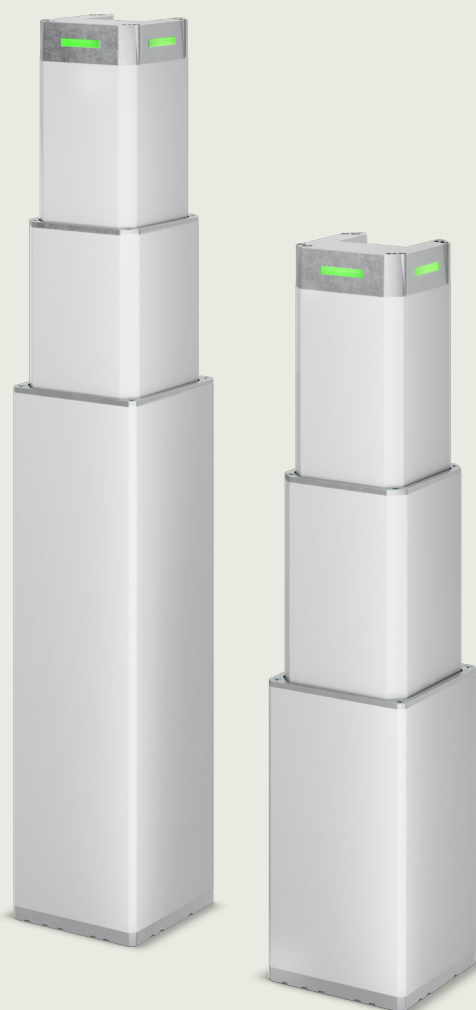

Contents

Preface	3
Terms of use	4
Introduction.....	5
Safety information	6
Warnings	7
Recommendations	8
Features.....	9
Options.....	9
Usage	9
Intermittence	10
Speed, load and current curves	11
Current limits	13
Installation and usage guidelines.....	15
Mounting guidelines.....	16
Customized mounting holes	18
Accuracy Overview LC3 IC	19
Position Accuracy	19
Rolling Back	20
Position Repeatability	20
Applications with Push and Pull	21
Built-in dimensions.....	23
Stop time.....	23
Bending	24
Static bending.....	24
Bending Over Lifetime	25
Dynamic bending	27
Parallel	29
Accessories	31
Service cable for Actuator Connect	31
Cable set - 5 meter Flying leads.....	31
IO-Link cable set.....	31
Modbus RTU cable set.....	31
Mounting plate with top screws.....	32
Mounting plate with bottom screws.....	32
Electrical installation.....	33
Maintenance	34
Repair	34
Main groups of disposal	34
Warranty	34
Contacts.....	37

Preface

Dear User,

We are delighted that you have chosen a LINAK® product.

LINAK systems are high-tech products based on many years of experience in the manufacture and development of actuators, lifting columns, desk frames, electric control boxes, controls, batteries, accessories and chargers.

This User Manual does not address the end user. It is intended as a source of information for the equipment or system manufacturer only, and it will tell you how to install, use and maintain your LINAK electronics. The manufacturer of the end product has the responsibility to provide a User Manual, where relevant safety information from this manual is passed on to the end user.

We are convinced that your LINAK product/system will give you many years of problem-free operation.

Before our products leave the factory, they undergo both function and quality testing. Should you, nevertheless, experience problems with your product/system, you are always welcome to contact your supplier.

LINAK subsidiaries and some distributors situated all over the world have authorised service centres, which are always ready to help you. Locate your local contact information on the back page.

LINAK provides a warranty on all products. (See warranty section).

This warranty, however, is subject to correct use in accordance with the specifications, maintenance being done correctly, and any repairs being carried out at a service centre, which is authorised to repair LINAK products.

Changes in installation and use of LINAK systems can affect their operation and durability. The products may only be opened by authorised personnel.

This User Manual has been written based on the present technical knowledge. LINAK reserves the right to carry out technical modifications and keeps the associated information updated.

LINAK A/S

Terms of use

LINAK® takes great care in providing accurate and up-to-date information on its products. However, the user is responsible for determining the suitability of LINAK products for a specific application.

Due to continual development, LINAK products are subject to frequent modifications and changes. LINAK reserves the rights to conduct modifications, updates, and changes without any prior notice. For the same reason, LINAK cannot guarantee the correctness and actual status of imprinted information on its products.

LINAK uses its best efforts to fulfil orders. However, for the reasons mentioned above, LINAK cannot guarantee availability of any particular product at any given time. LINAK reserves the right to discontinue the sale of any product displayed on its website or listed in its catalogues or in other written material created and produced by LINAK, LINAK subsidiaries, or LINAK affiliates.

All sales are subject to the 'Standard Terms of Sale and Delivery for LINAK A/S' available on LINAK websites.

LINAK and the LINAK logotype are registered trademarks of LINAK A/S. All rights reserved.

Introduction

The LC3 IC is a smart electric lifting column featuring an integrated controller that allows for seamless connectivity in industrial applications through a variety of interfaces. Designed and field-tested for robust, long-lasting performance, the LC3 IC is a reliable solution for your vertical lift applications.

The LC3 IC is an ideal choice for automation technology that streamlines processes between machines and improves the working environment. And if your application requires a strong foundation for managing high loads and enhancing stability, you can run several columns in parallel.

Speed up your development with these benefits:

- **Three-stage telescopic design:** High performance in a compact size – flexible mounting in both vertical directions
- **Many customisation options:** 200–1,100 mm stroke lengths, 24 or 48 V, up to 6,000 N loads and up to 100 mm/s
- **Integrated Controller:** Direct control over a wide range of industrial PLCs
- **Brushless DC motor:** Smooth movement and long service life
- **Status LED and diagnostics:** Easy troubleshooting to increase up-time

With its quiet operation, this discreet electric lifting column also enhances the work environment.

Safety information

Please read this safety information carefully.

Be aware of the following three symbols throughout the user manual:



Warning!

Failing to follow these instructions can cause accidents resulting in serious personal injury.



Recommendations

Failing to follow these instructions can result in the product suffering damage or being ruined.



Additional information

Usage tips or additional information that is important in connection with the use of the product.

Furthermore, ensure that all staff who are to connect, mount, or use the lifting column are in possession of the necessary information and that they have access to a descriptive manual.

Persons who do not have the necessary experience or knowledge of the product/products must not use the product/products.

Besides, persons with reduced physical or mental abilities must not use the application, unless they are under surveillance or they have been thoroughly instructed in the use of the apparatus by a person who is responsible for the safety of these persons.

Moreover, if children are to use the application - they must be under surveillance to ensure that they do not play with the application.



Warnings

- Always use a cable lock to ensure cables are fixed and not squeezed, pulled, or subjected to stress or damage.
- Make a proper cable installation and inspect regularly for wear, damage, and jarring sounds to avoid cable interruption and lifting column defects. Defective parts must be replaced.
- Damaged parts can cause moisture to gather and lead to dangerous electrical connections between metal parts and wires.
- Always check correct assembly after mounting or service and ensure the cable lock is fitted.
- Do not exceed the max. nominal pull or push load specified on the label.
- Do not add dynamic load when changing between pull and push.
- Do not manually adjust anything during movement or while connected to power supply unit, as this may cause personal injury.
- Cables must remain plugged in the column during cleaning to prevent water ingress.
- After service inspection, the application must be tested for correct functionality before use to avoid misalignment between two or more columns moving in parallel.
- If LC3 IC is used in ceiling-hang applications, consider if additional third-party safety devices are required to prevent personal injuries.
- Not to be used horizontally.
- The product is NOT to be opened by unauthorized personnel.
- LC3 IC is heavy (more than 20 kg). To avoid personal injury and product damage, DO NOT DROP!
- Do not loosen any screws on the LC3 IC, as this can cause collapse of the column!
- The lifting column can become a functional safety system compliant with EN ISO10218-2. To integrate the LC3 IC into a functional safety chain, external safety devices such as safety contactors/relays must be implemented.
- Because of the special sealing gasket on the power and signal cable, option 'F600' is rated with IP44. However, this protection level only applies when the column is installed up side right with the top plate facing upwards. If you are using options 'F700' with an RJ45 plug, it can only achieve an IP4X rating.
- Pinching Hazard Warning: Be aware of the risk of pinching during column movement. If a top plate larger than the smallest profile is mounted, it poses a pinching risk for objects higher than 4 cm. Additionally, mounting the column upside down at ground level creates a pinching hazard at the moving profile ends. Please implement appropriate safeguards to prevent injury.



Recommendations

- Always follow the important LC3 IC mounting guidelines and LINAK specifications to ensure correct functionality
- Self-designed mounting plates must cover the entire bottom plate and be strong enough to carry the load
- Do not use chemicals for cleaning nor remove sliders grease on profiles
- Intended for indoor use only and not for use in harsh environments like pool or marine environments and agriculture buildings with ammonia vapours
- Assure free space for movement of the application in both directions to avoid blockage
- Listen for unusual sounds and watch for uneven running during operation. Stop the lifting column immediately if anything unusual is observed
- When using Actuator Connect to modify parameters, please proceed at your own risk. Ensure that the soft start and soft stop times are set to no less than 500 milliseconds. (1500 ms for the 1000 N version)
- Avoid dynamic load changes while the column is operating, as moving loads can increase the total load beyond the column's specifications, potentially shortening its lifespan and causing stick-slip issues
- For applications with suitable built-in dimensions, we recommend heavy-duty profiles due to their enhanced resistance to side forces and bending moments, especially under off-center loads. Standard profiles are ideal for applications requiring compact dimensions without off-center loads
- Avoid clamping the column on the outer profile, as this can alter the system's internal friction and negatively affect the column's lifespan
- Avoid placing the column in dusty environments, as this can impact the sliders and reduce the column's lifespan. If a dusty environment is unavoidable, use a cover solution to protect the column

Features

- Maximum speed up to 100mm/s depending on spindle pitch
- Anodized aluminium profiles with zinc bottom and top plate
- Noise level below 58 dB(A)
- Highly efficient hollow and solid spindle with acme thread
- High self-lock ability due to integrated brake
- Incremental encoder with contact-less calibration (Zero-point)
- Position repeatability: +/- 0.3mm
- *Weight: 20.5 kg for 400 mm stroke; additional 1.7 kg for each additional 100mm stroke (Cable not included; weight varies by selected options)*

Options

- 24 or 48 V DC brushless motor
- Stroke length from 200 mm to 1,100 mm in steps of 100mm (2,000 - 6,000 N up to maximum 700 mm in push applications)
- Maximum nominal load from 1,000 - 6,000 N
- Rated for ingress protection up to IP44:
 - F600 IP44 (only if the column is mounted with the top plate upwards)
 - F700 IP4X
- Integrated controller with several interface options:
 - I/O
 - CANopen
 - CAN J1939
 - Modbus RTU
 - Modbus TCP/IP
 - EtherNet/IP
 - PROFINET
 - IO-Link

Usage

- Duty cycle: 20% at full load for 1,000 N *(4 min. run, 16 min. rest)*
Duty cycle: 10% at full load for 2,000 N, 4,000 N, 6000 N (2 min. run, 18 min. rest)
- Operation temperature: +5°C to + 40°C
- Storage temperature: -40°C to + 70°C
- Atmospheric pressure: 700 to 1060 hPa
- Meters above sea level: *Tested to* 2000 meters
- Avoid dusty environments

Approvals:

- EN 61000-6-2:2019 – Part 6-2
- EN 61000-6-4:2019 – Part 6-4

Intermittence

Because the motor and drive within the actuator/lifting column produce heat during operation, the actuator/lifting column need pauses to avoid excessive wear and overheating.

Intermittence is the ratio between the time when the actuator/lifting column is in motion and when it is paused.

The duty cycle stated in 'Usage' is the intermittence with which the device can be used within the defined 'Operation temperature range' at full load without overheating.

The ratio can be altered with changes to the load and/or changes in the ambient temperature.

The following information and graphic is only valid for the 1000 N option:

The LC3 IC may run continuously for up to 15 minutes with an ambient temperature within the operating range of +5°C to +40°C with full load.

The curve describes the duty cycle in % with a given load in a specific ambient temperature.

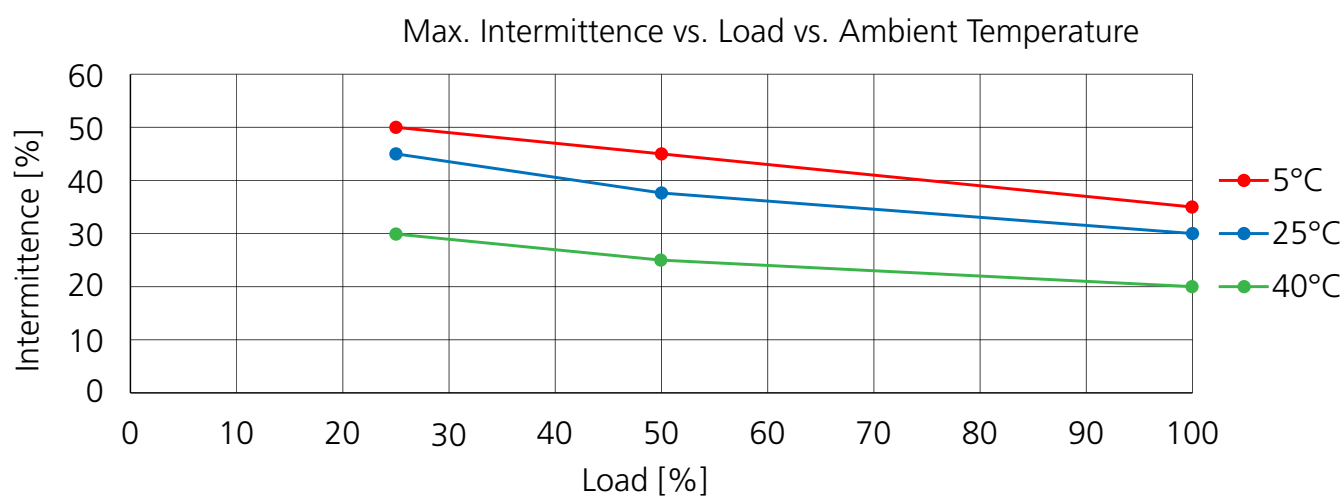

Speed, load and current curves

The values provided below represent typical measurements obtained under controlled conditions, with a stable power supply and an ambient temperature of 20°C. Please note that the current consumption figures are recorded without any off-center load. Introducing an off-center load will result in increased current consumption.

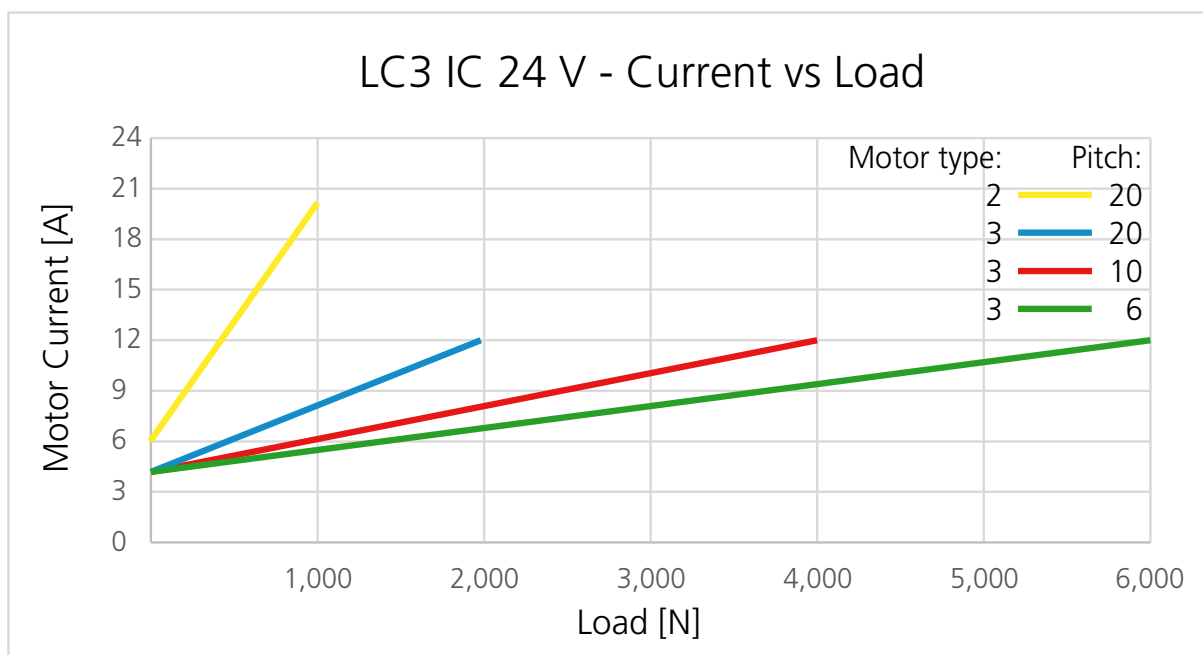
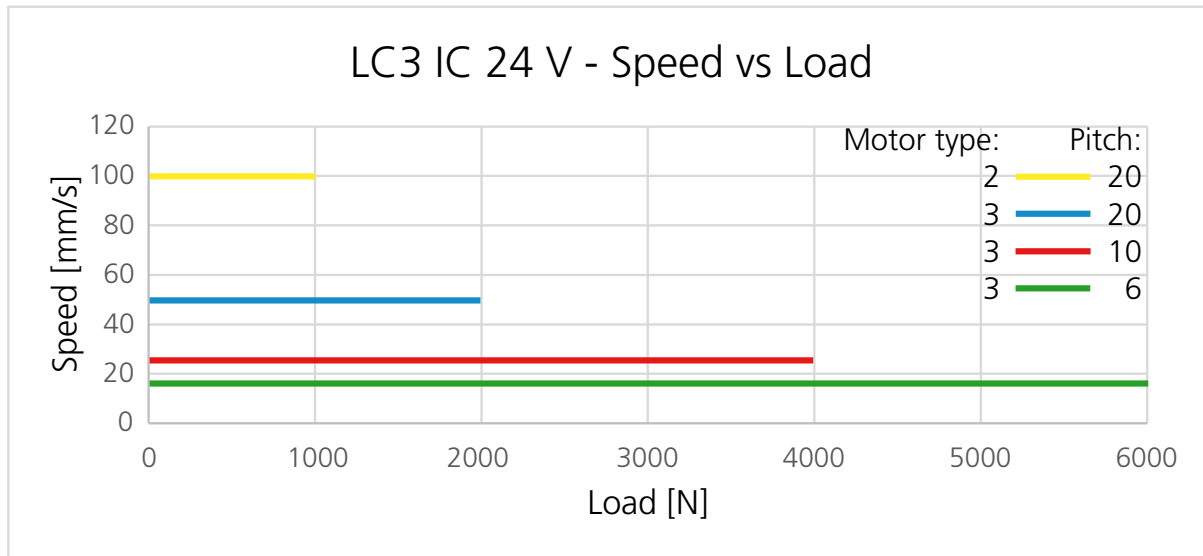

Speed, load and current curves

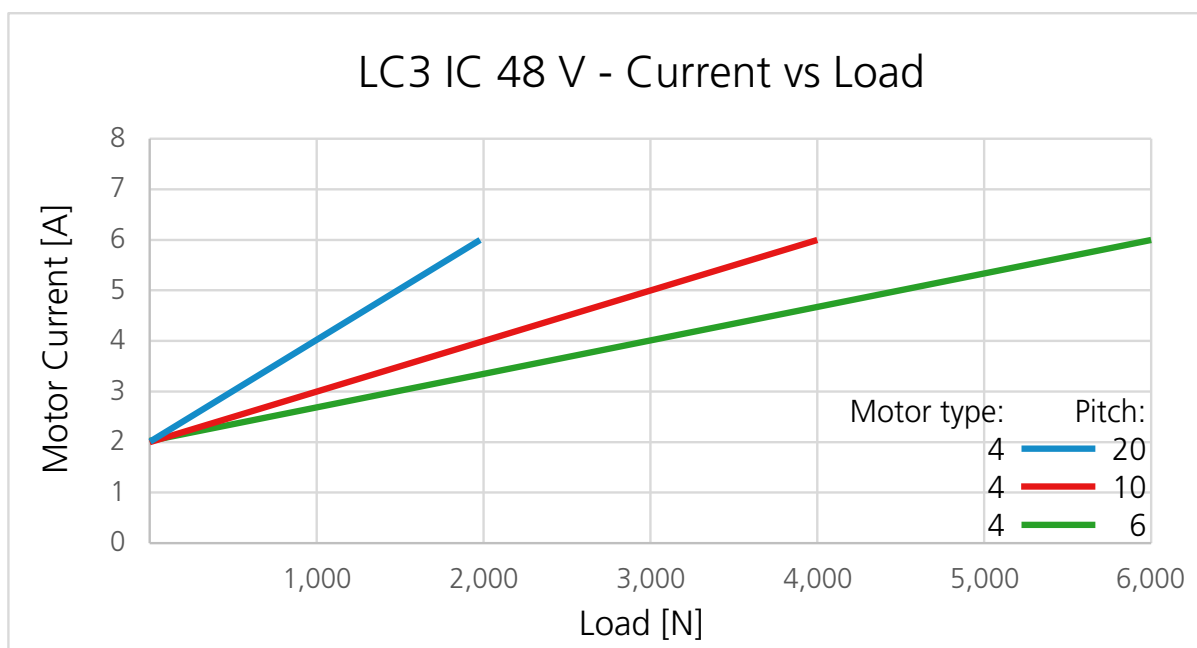
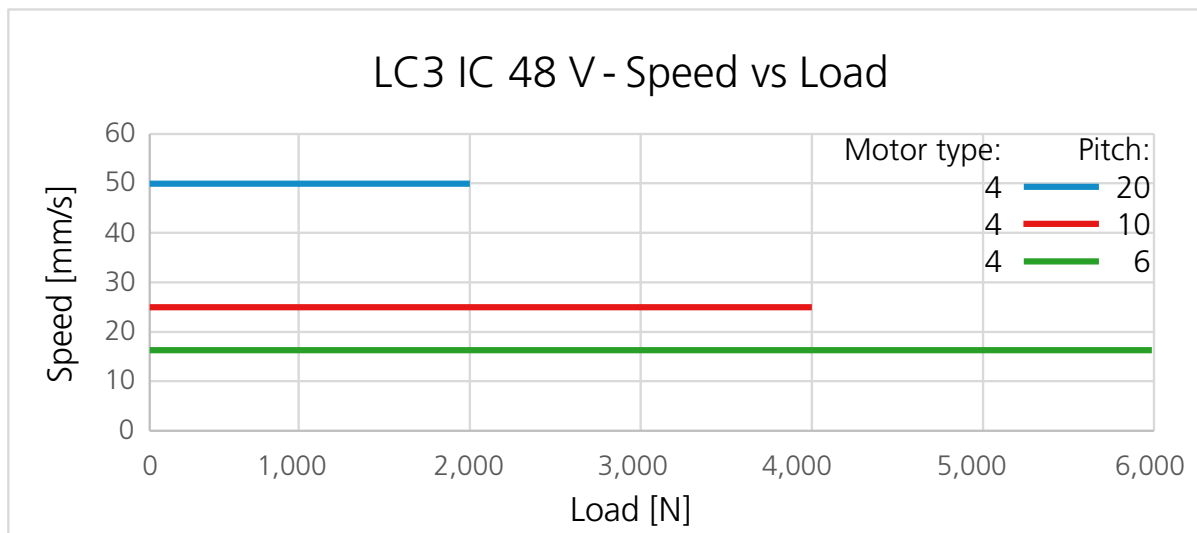

Motor current vs power supply current:

When choosing a suitable power supply, please be aware of how the lifting column current consumption is defined. The current feedback from the lifting column via bus communication and the Actuator Connect™ service tool can appear higher than the current measured at your power supply. This is due to the way the lifting column speed is regulated and can affect the expected result of a set current limit. The internal current limit is based on the motor current and not the current of the power supply.

Example:

If the power supply current reads 16 amps, the motor current may be measured to 19 amps due to the speed regulation. The set current limit is based on the motor current and if set to 18 amps, it can trigger an over-current state even though the power supply current is at 16 amps.

Current limits

The current limiting algorithm

If the Lifting column's current consumption rises above the set limit, the Lifting column regulates and tries to keep it below the set current limit by reducing the PWM and therefore also the speed accordingly. The Lifting column does this continuously, until the Lifting column stops moving (mechanically blocked) - something that is determined by monitoring the Hall feedback signal. If there are no changes to the Hall feedback signal during the set time frame, the integrated controller will cut power to the h-bridge motor circuit.

If the Lifting column is stopped due to the above-mentioned criteria, it automatically drives slightly in the opposite direction to reduce the torque in a blocking situation.

This is visualised in the figure below:

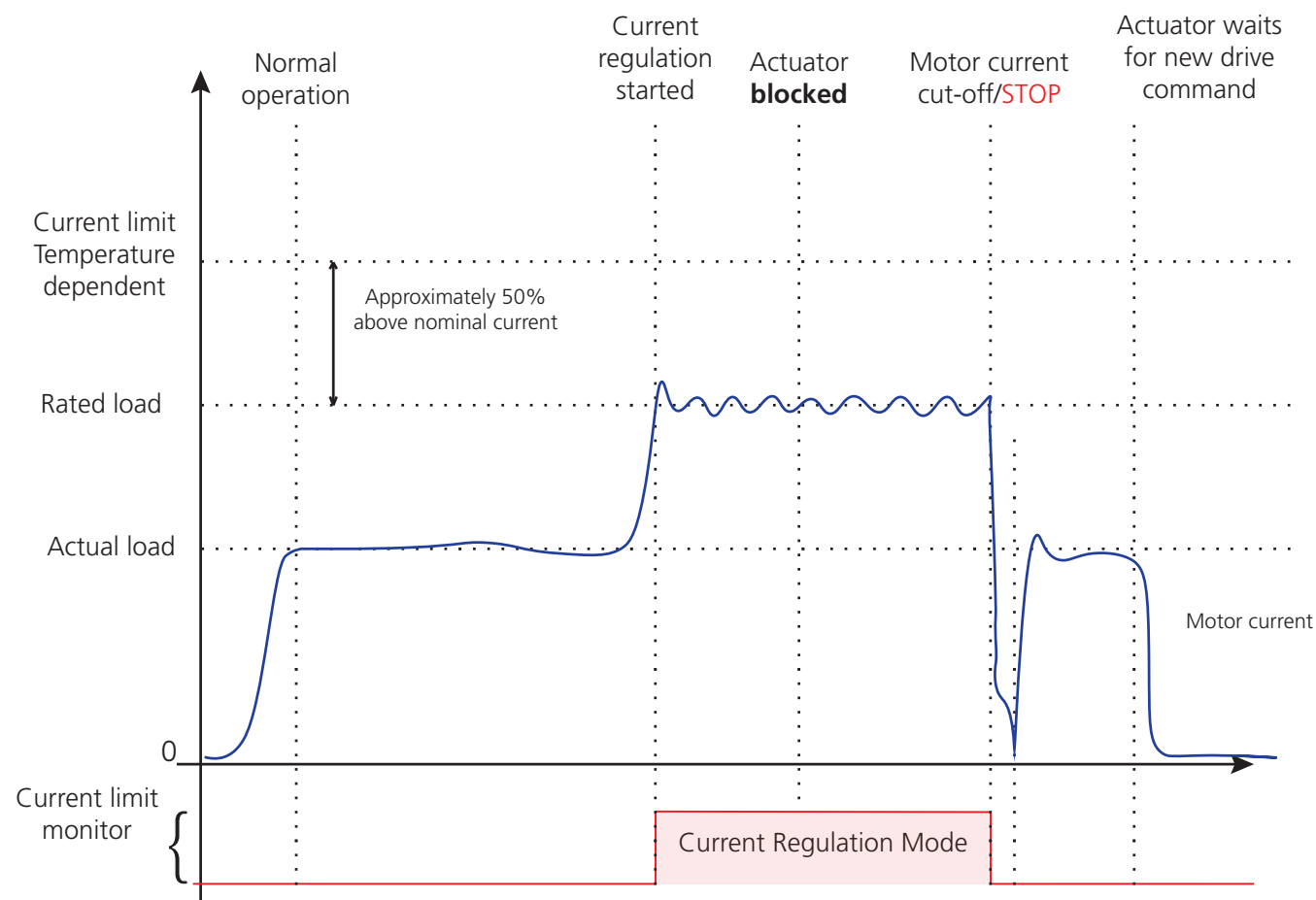



Figure 1

This control feature makes it possible to avoid loading the internal mechanical system of the Lifting column above its specification, which ultimately means a longer life for the Lifting column, especially in an abuse scenario.

 The Lifting column comes with factory default current limits. These values can be customised with the 'Protection' option in Actuator Connect™ or when ordering the Lifting column.

Current limits

LC3 IC comes as default with the following current limits:

Platform		24V Fast (1000N)	24 V	48 V	Reference temperature 0°C
A7	CAN SAE J1939 – Industrial	25	20	10	Above
A8	CANopen – Industrial				
B3	I/O Basic				
F3	I/O Full				
0A	IO-Link	25	20	10	Below
14	Modbus RTU RS485				
0E	Modbus TCP/IP				
2E	EtherNet/IP				
4E	PROFINET				

Current limits can be set in the 'Protection' option in Actuator Connect™ or configured when ordering the actuator.

Installation and usage guidelines

Before mounting/dismounting the lifting column ensure that the following points are observed:

- The lifting column is not in operation
- The lifting column is free from loads that could be released during this work.

Before the lifting column is being put into operation, check the following:

- The lifting column is correctly mounted as indicated in the relevant user instructions
- The equipment can be freely moved over the lifting column's whole working area
- The lifting column is connected to a mains electricity supply/transformer with the correct voltage, and which is dimensioned and adapted to the lifting column in question
- Ensure that the voltage applied matches to the voltage specified on the lifting column label
- Ensure that the connection screws are secured safely

During operation:

- Periodically run the column through the stroke area between 35 mm and 70 mm. This is the calibration zone for the zero point. When the column moves through this area, the controller will automatically calibrate the incremental encoder feedback system. This process corrects any offset that may occur from column sinking or movement without power
- If you see black or dark stripes on the column, it is likely due to dust or small particles on the slides. Avoid placing the column in very dusty environments, as this can affect the sliders and reduce the column's lifespan. Use a cover solution if a dusty environment is unavoidable
- For the best accuracy, always move to the desired position from the same direction
- Ensure that the LC3 IC has a load of minimum 100 N. Failure to meet this requirement may cause the actuator to shift between pulling and pushing, which can impact the accuracy negatively

Mounting guidelines

The LC3 IC is designed exclusively for vertical use and can be mounted either right side up or upside down, without any impact on performance. However, note that the direction of potential pinching hazards will change when the column is turned. In some cases, mounting the column upside down may eliminate the need for an energy chain.

The LC3 IC is suitable for both push and pull applications and can be installed on the ground, top-hanging, or on a mobile unit. It is crucial to secure the column firmly to a stable base, as any bending in the base will transfer through the column to the application and vice versa. To ensure maximum bending resistance and prevent instability caused by base deflection, the base must have a section modulus of at least 19,141 mm³.

Ensure that the column is mounted in such a way that the cable connector is accessible. The column features a status LED on three sides, and we recommend positioning it so that the status is always visible.

 Only the LC3 IC option "F600" is IP44 rated, and this rating is only valid when the column is mounted right side up. (*Mounting direction option "1"*).

Upside down Right side up
Innerprofile down Innerprofile up



If the column is to be used with a constant high off-centre load, we recommend to install the constant weight in one of the 3 ways illustrated by the green symbols. It is not recommended to install the weight on the opposite side of the mechanical endstop as illustrated with the red symbol. This installation can create an uneven movement and noise when the lifting column reaches the endstop position.

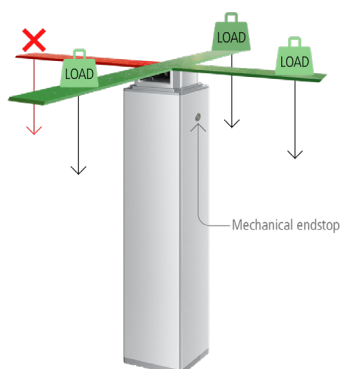

Use 4 pcs. M10 8.8 bolts at each end of the column for mounting to the application.
 The screw depth must be min. 20 mm and max. 30 mm in the aluminium profile.

 Secure the screws with a torque of: 35 Nm.

 *All 8 M10 screws must be fully inserted and securely fastened to ensure proper functionality of the column and the mechanical endstop.*
-Failure to do so may result in the top and bottom plates being pressed off the column.

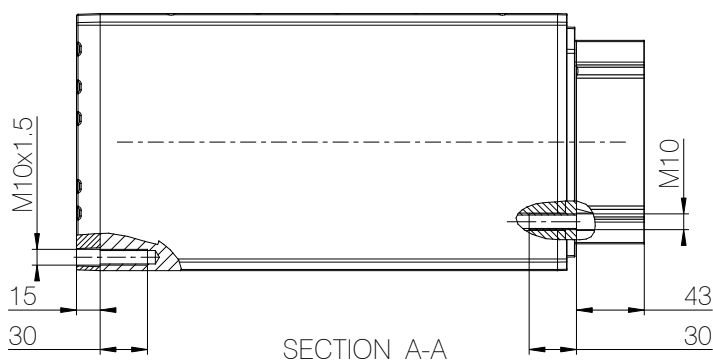



15 mm distance to thread

Bolt depth min. 20 mm

43 mm distance to thread

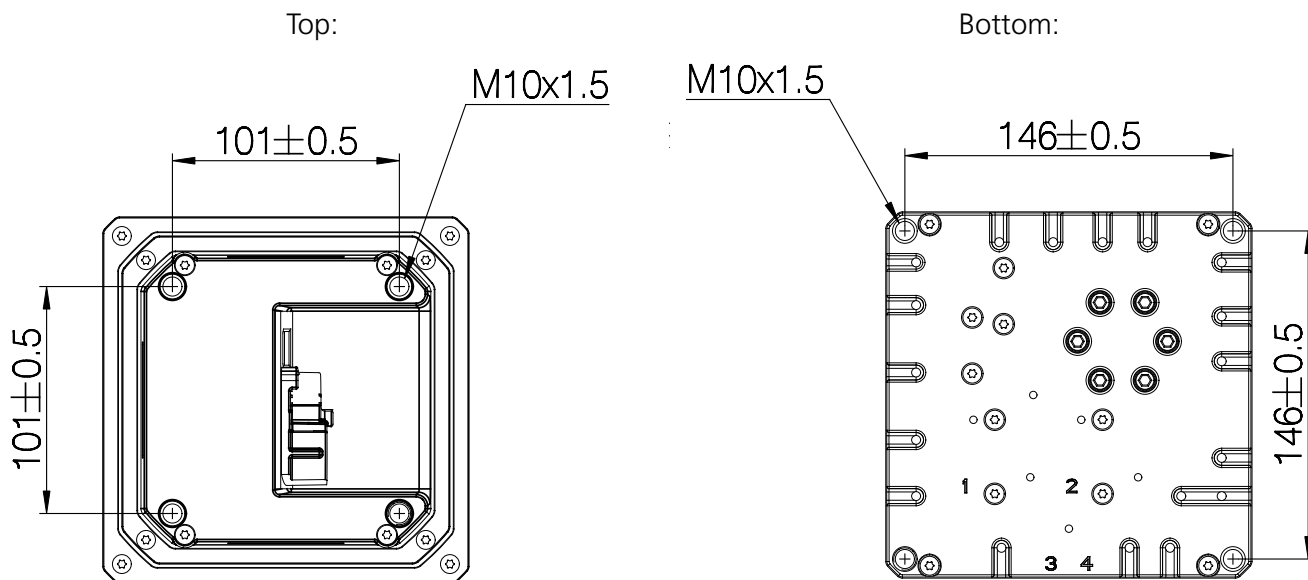
Mounting holes



 Bolts of high quality steel 8.8 or 10.9 must be used to secure safe mounting of the LC3 IC to the application.

 It is recommended to use bolts with thread-lock adhesive

Customized mounting holes

You can order LC3 IC columns with mounting holes on the outer profile, available on all four sides. However, ensure that the holes are not at the same height on any corner to avoid collisions. The graphic shows the allowable hole sizes and their placement on the profile.

Maintain the minimum distances from the top and bottom plate.

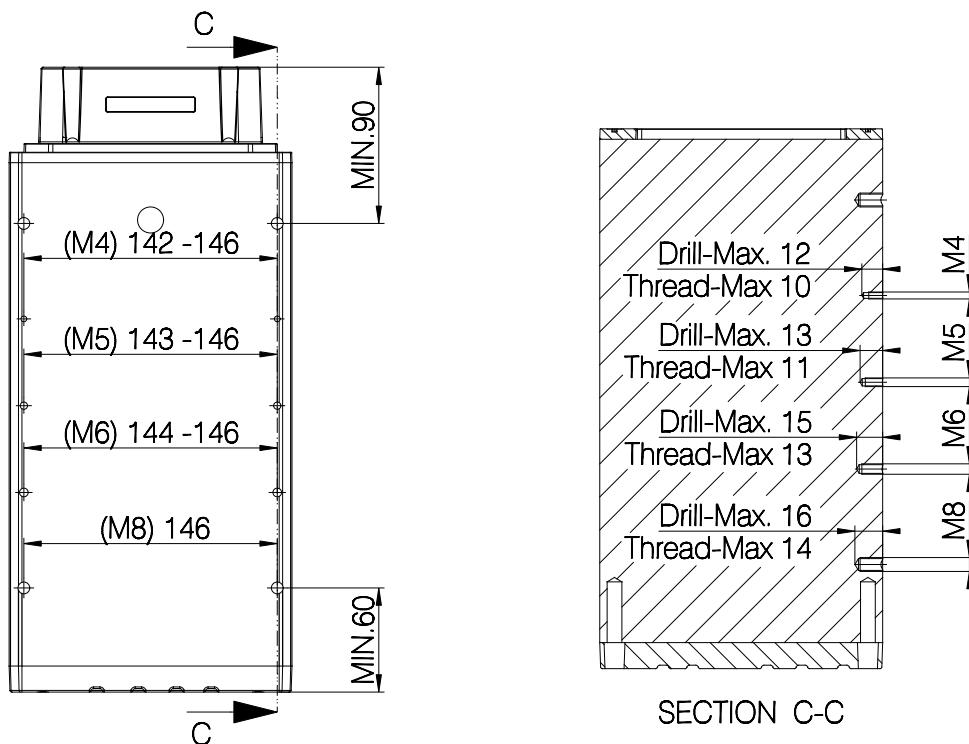

Screws used for mounting of a product on the side of the LC3 IC must be 8.8.

Screw type	M8	M6	M5	M4
Screw torque Nm	17	7	4	2

i Customized mounting holes require a minimum order quantity. LINAK will evaluate each case and its potential to determine if customized mounting holes can be implemented.

Accuracy Overview LC3 IC

This chapter provides an overview of the accuracy of the lifting column. The presented data is estimated and not a guarantee of achieving a specific target position. The accuracy of the lifting column is influenced by factors such as spindle pitch, production batch, and brake activation. For optimal results, always approach the desired position from the same direction. The information below outlines key factors affecting accuracy, repeatability, and other aspects of linear movement.

Position Accuracy

Position accuracy indicates how precisely the lifting column reaches the target position. This value considers built-in tolerances, stroke tolerance, and rolling back (explained further below). For example, if you order a lifting column with a built-in dimension of 200mm and extend it by 100 mm, you would expect it to stop at a length of 300 mm. Position accuracy describes how close the lifting column will stop to this position.

1000 N, 2000 N, 4000 N and 6000 N option	
Position accuracy for push	The lifting column will stop between the target length and 1.5 mm before it.
Position accuracy for pull	The lifting column will stop between the target length and 1.9 mm behind it.

Case: When moving to a target position to achieve the desired length, the built-in tolerances, stroke tolerance, and roll-back can affect accuracy. These three factors collectively represent the position accuracy of the lifting column's length.

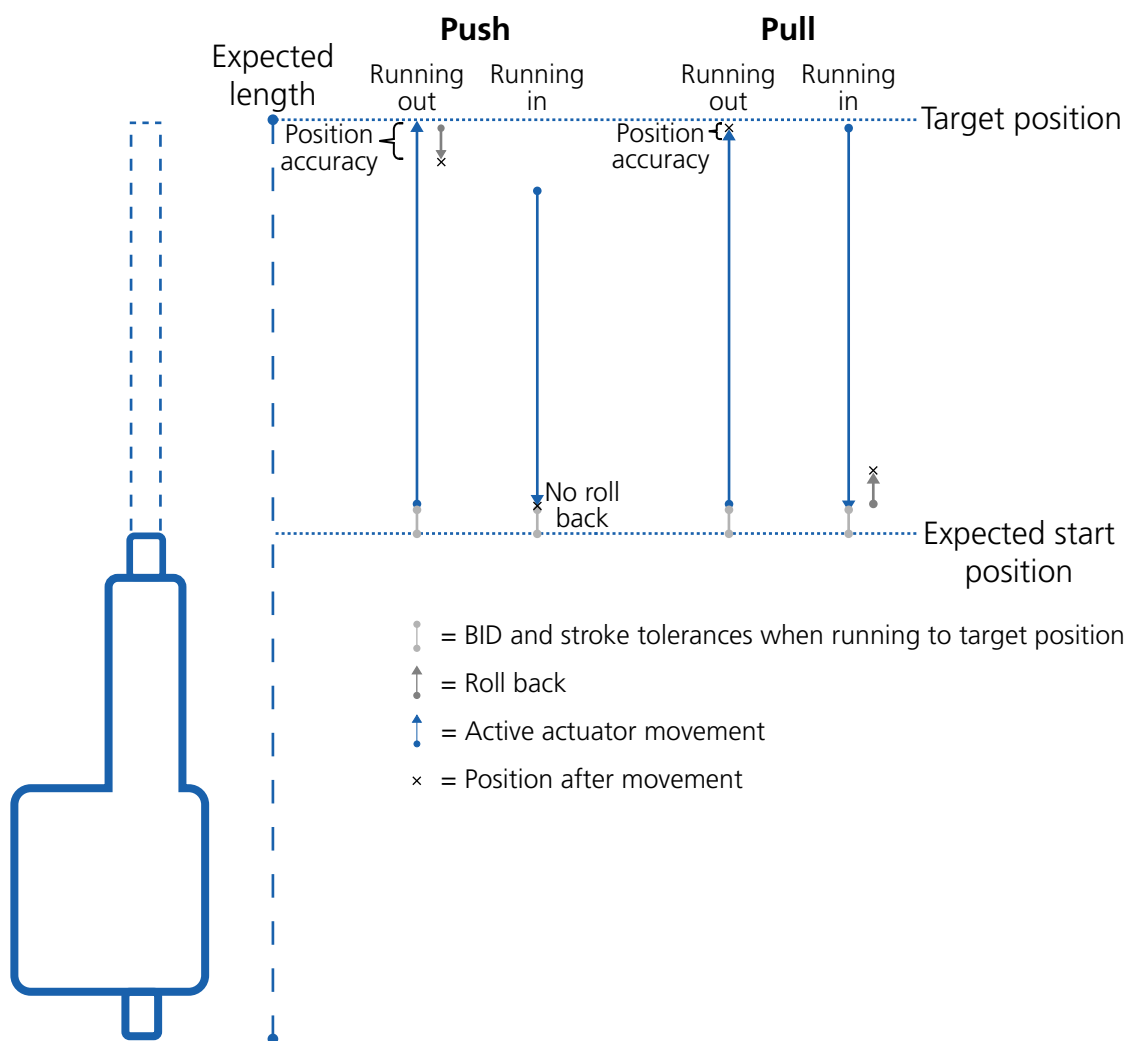

Rolling Back

When the lifting column moves against the load's force, such as during outward movement under a push force, a brief rollback may occur upon stopping. This is due to brake engagement for self-locking, similar to parking a car uphill. If the force direction aligns with the movement direction, rollback does not occur as the brake is already engaged. Rollback is factored into the position accuracy.

	Unit	1000 N and 2000 N options	4000N option	6000 N option
Rolling back	[mm]	0.7-1	0.3-0.8	0.1-0.4

Case: Occurs when the lifting column runs out with push load or runs in with pull load.

Position Repeatability

Position repeatability refers to the lifting column's ability to repeatably stop at the same position. Achieving these values requires moving toward the target position from the same direction. Position repeatability can be used when relative movement is important, such as moving exactly 100mm from another position, regardless of built-in tolerances.

	Unit	1000N, 2000N, 4000N and 6000N option
Position repeatability for pull or push	[mm]	± 0.3

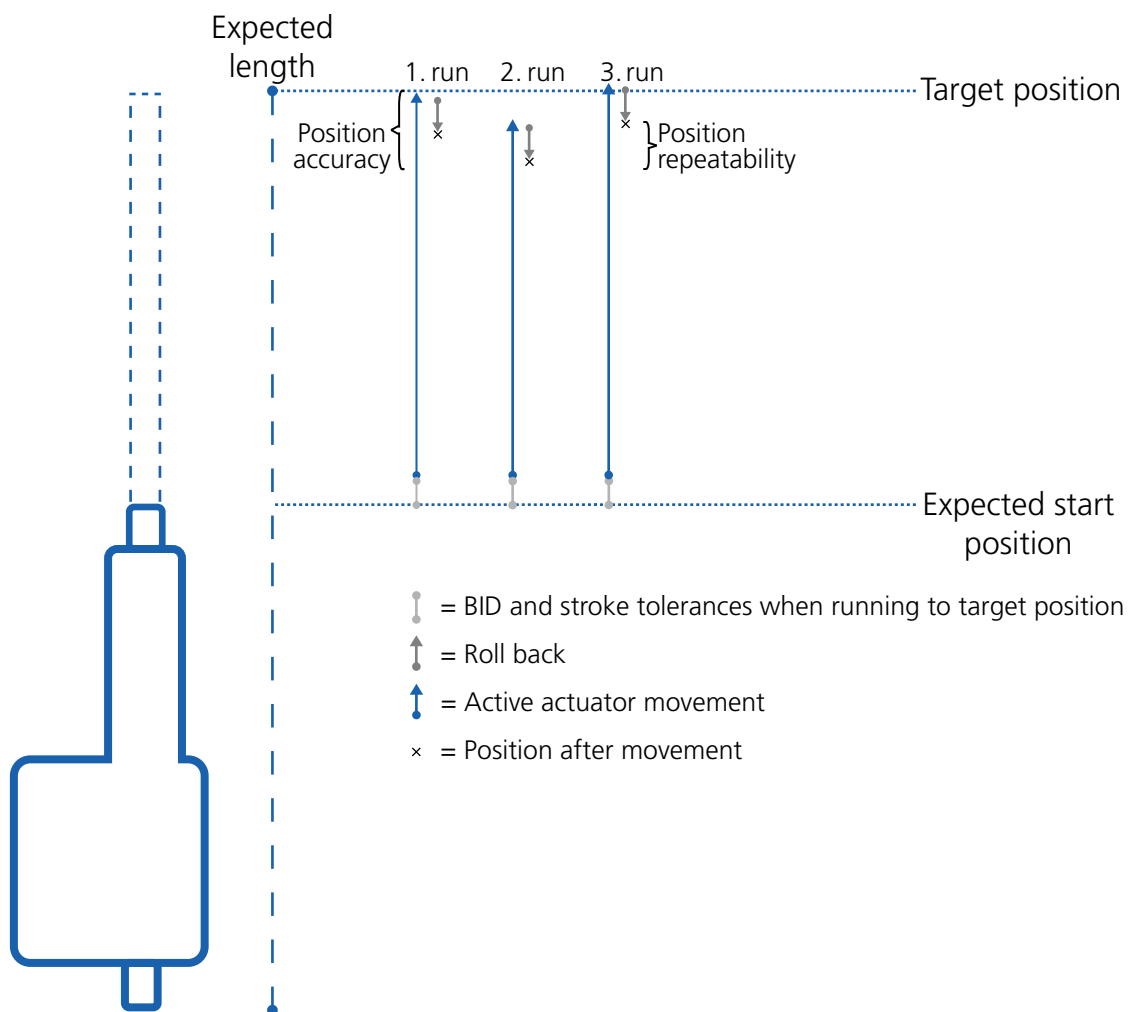

Applications with Push and Pull

Clearance Movement

The lifting column experiences clearance movement when switching between push and pull forces. This movement also occurs when the lifting column is not actively moving. Part of this movement is detected by the internal position measuring system, which updates the lifting column position. However, some movement remains undetected by the integrated controller. The table below shows detected and total clearance movements. Consider this clearance in applications that switch loads between push and pull.

Type	Unit	1000 N and 2000 N option	4000 N option	6000 N option
Clearance between push and pull (detected by feedback system)	[mm]	7.5 (4.85)	4.6 (2.72)	4.2 (1.7)

Case: Clearance movement can affect small movements when the lifting column is unloaded.

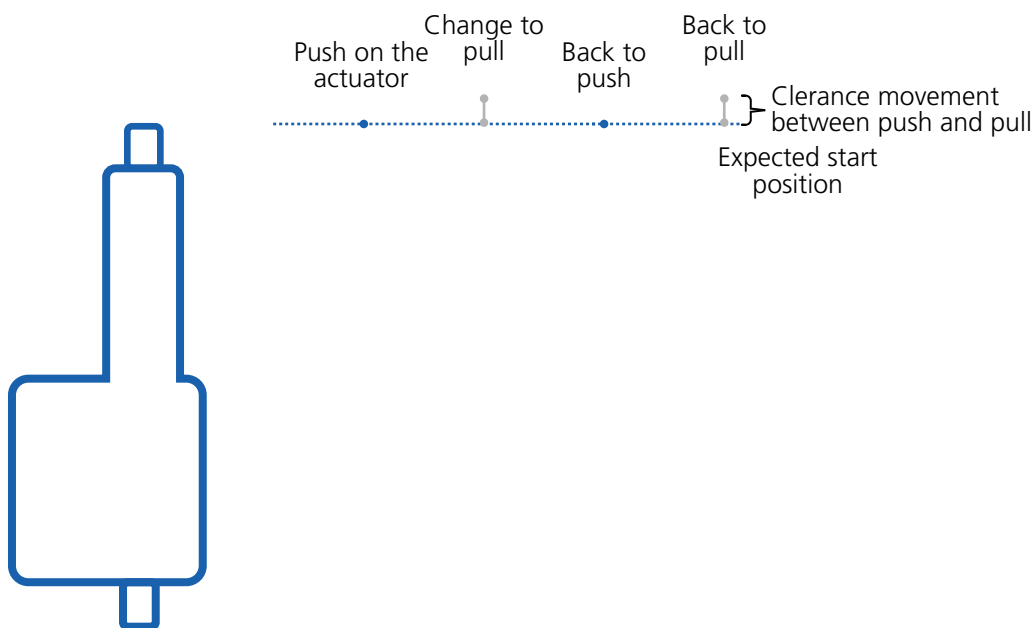

Position Offset

The lifting column's relative position system is factory-calibrated with a push force. The contact-less calibration system (Zero Point) recalibrates the position feedback system each time the lifting column crosses the Zero Point area (35-70mm of stroke). When switching from push to pull, a position offset may occur because of clearance movement, disappearing upon crossing the zero point. The same applies when switching back from pull to push. When the lifting column does not cross the zero point after a switch from pull to push, the following position offset will occur on your position accuracy.

	Unit	1,000 N and 2,000 N option	4,000 N option	6,000 N option
Position offset	[mm]	4.5	3	1.5

Case: An offset becomes apparent when the load direction changes (from push to pull or vice versa) and the lifting column moves to a target position. This position offset can be easily avoided by calibrating the lifting column each time the load direction changes.

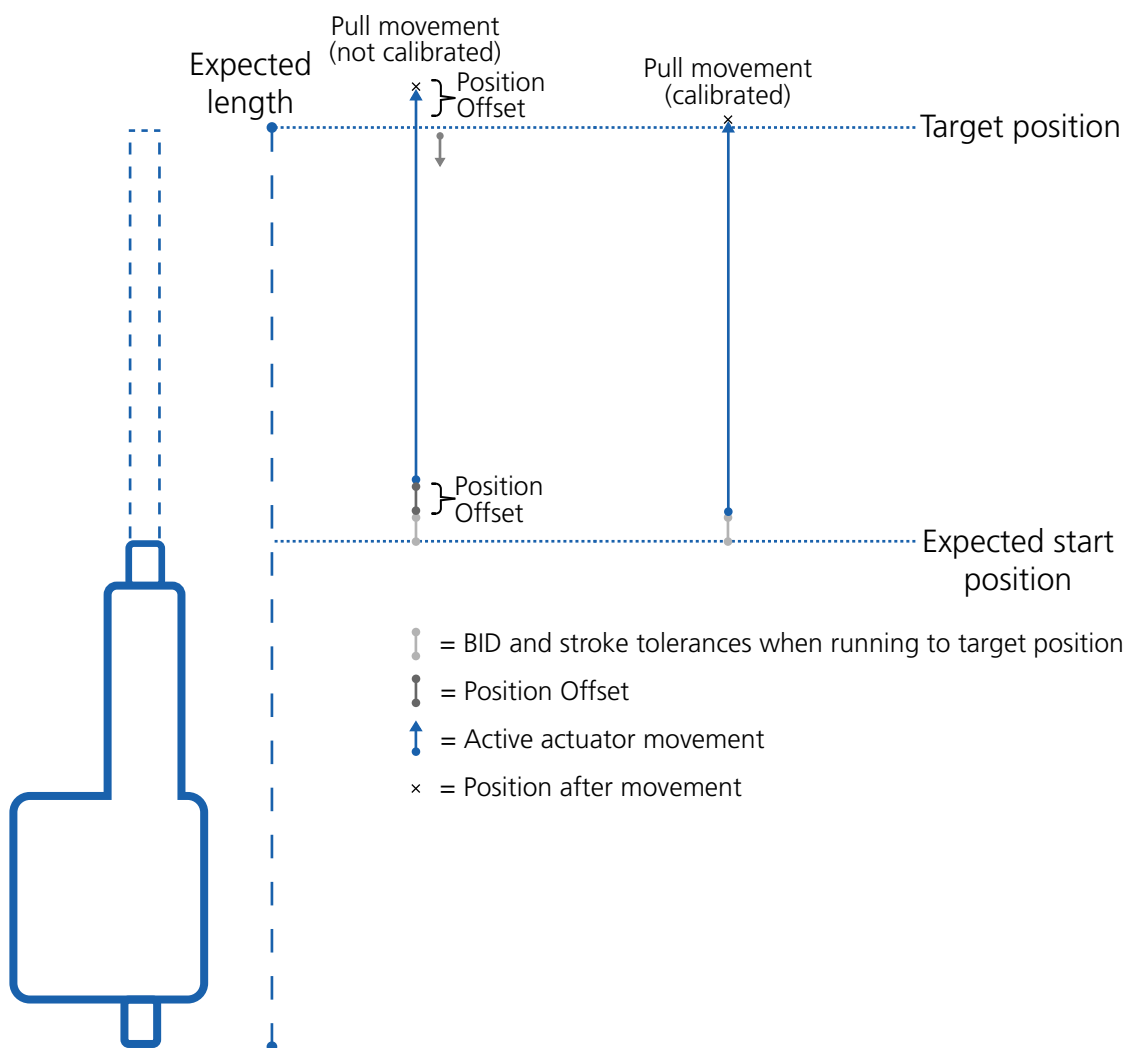

Built-in dimensions

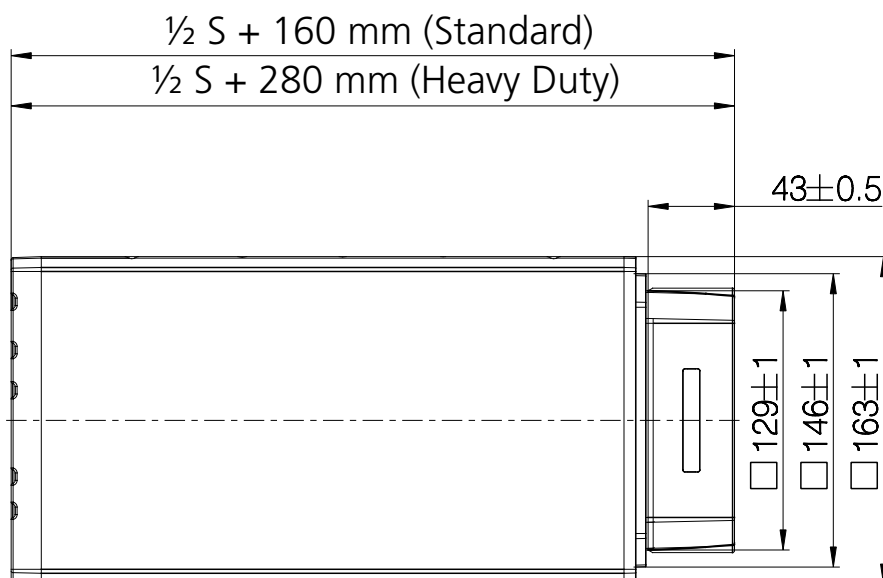

Built-in dimensions [mm]										
Stroke [mm]	200	300	400	500	600	700	800*	900*	1,000*	1,100*
Standard profile	360	360	360	410	460	-	-	-	-	-
Heavy Duty profile	480	480	480	530	580	630	680	730	780	830

* Only for 1,000 N and heavy-duty profile option available.

Stop time

When the speed of the column is reduced or the motor power is removed, the brake will engage and stop the column and self-lock it. The following table shows the stop time when a stop signal is sent, or the motor power is removed.

Load option	Soft stop when stop signal is sent	Stop time by power loss
2,000, 4,000 and 6,000 N	1,500 ms	500 ms
1,000 N	1,500 ms	500 ms



Ensure that the soft start and soft stop times are set to a minimum of 500 milliseconds. For the 1000N option, these parameters must be no less than 1500 milliseconds.

Setting stop times too short can cause the back electromotive force of the motor to damage the integrated controller of the columns

Bending

Profile Options:

The LC3 IC lifting columns are available in two profile options: standard profiles and heavy-duty profiles.

Recommendations:

- Heavy-Duty Profiles:** We generally recommend using heavy-duty profiles for applications where the built-in dimensions are suitable. These profiles offer increased overlap, resulting in sliders that are positioned further apart. This design enhances resistance against side forces and bending moments, making heavy-duty profiles ideal for applications involving off-center loads on the column.
- Standard Profiles:** For applications where there is no off-center load and where minimal built-in dimensions are required, standard profiles are suitable. These profiles provide a compact solution without compromising on performance only for central load applications.

Static bending

Both standard and heavy-duty profiles can withstand the following forces:

M_B				
Push forces (F_A)	1,000 N	2,000 N	4,000 N	6,000 N
Standard profiles	1,000 Nm	1,000 Nm	1,000 Nm	1,000 Nm
Heavy duty profiles	3,000 Nm	3,000 Nm	3,000 Nm	3,000 Nm

M_B				
Pull forces (F_A)	1,000 N	2,000 N	4,000 N	6,000 N
Standard profiles	1,000 Nm	1,000 Nm	1,000 Nm	1,000 Nm
Heavy duty profiles	3,000 Nm	3,000 Nm	3,000 Nm	3,000 Nm

For optimal performance and safety, select the profile that best matches your application’s requirements.

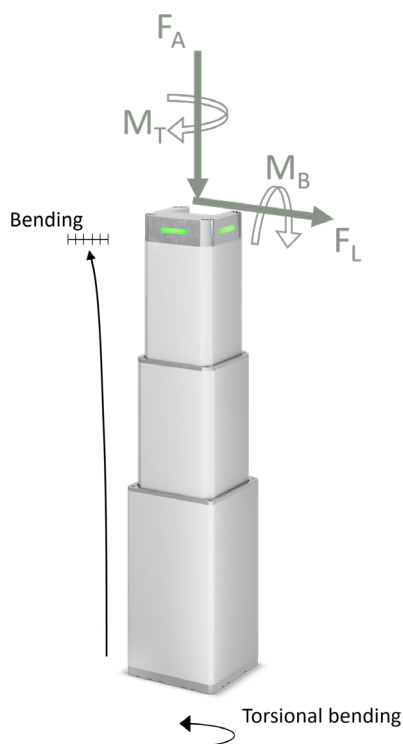

Bending Over Lifetime

A constant applied bending moment on the lifting column can cause wear on the sliders within the column over time. The accompanying graph illustrates how different bending moments (MB, MT) affect the bending of a column. The data provided is representative of columns with strokes of 900 mm and 1,100 mm, each supporting a load of 1,000 N.

The runtime influences the bending behaviour of the column. The graph compares the bending characteristics of a new column with a 900 mm stroke (0.1 km runtime), a new column with a 1,100 mm stroke, and a used column with a 900 mm stroke after 135 km runtime. The used column experienced a constant off-center load of 100 kg and a bending moment of 350 Nm over its runtime.

Bending with bending moment M_B

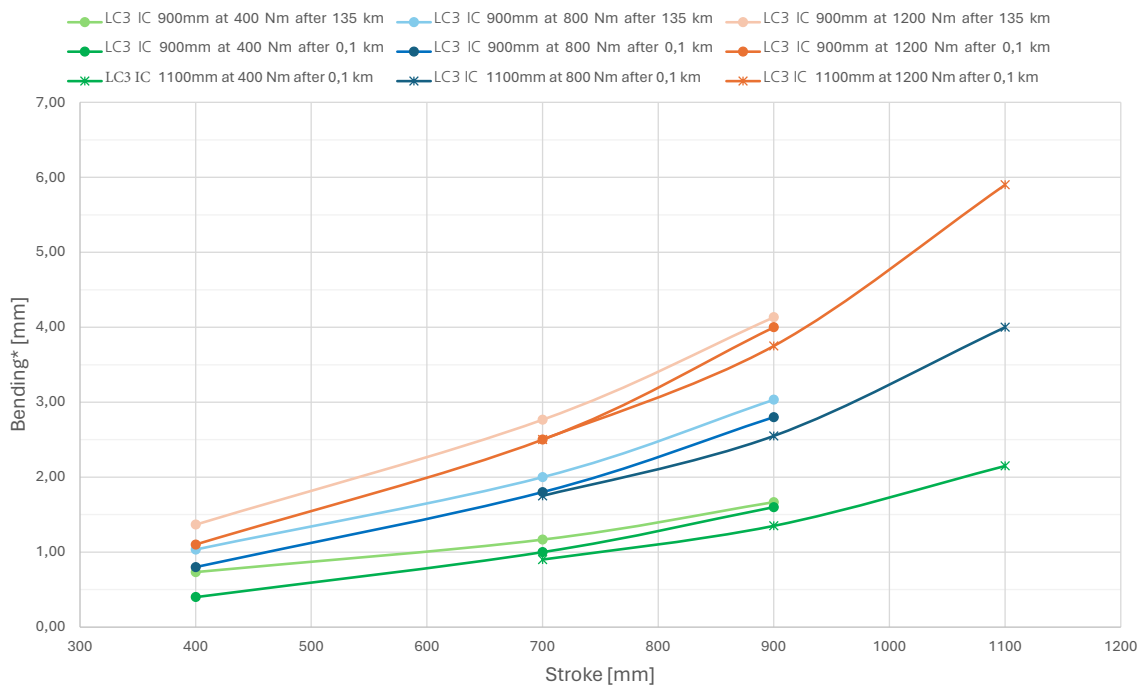

* The bending is measured at the top of the column in a horizontal direction.

Bending with torsional moment M_T

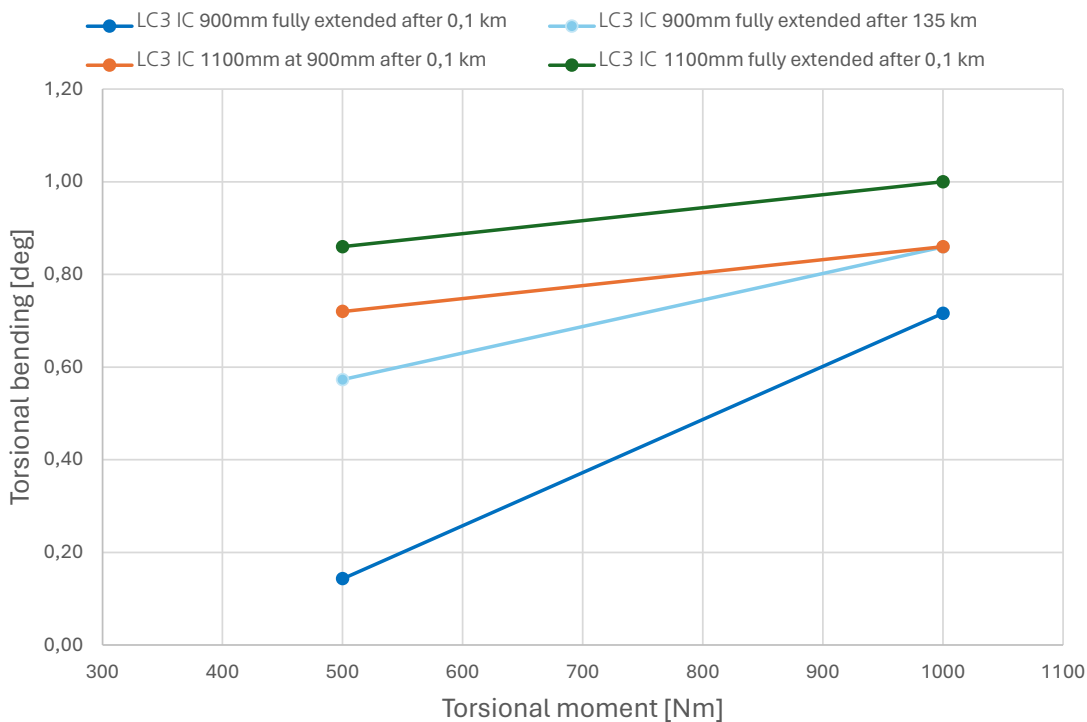

Dynamic bending

Dynamic bending occurs when a column is extending or retracting while a static or dynamic bending moment is applied. Only heavy-duty profiles are engineered to handle dynamic bending.

The following table outlines the permissible dynamic bending moments for columns in operation:

M_B - Dynamic				
Pull and Push forces (F_A)	1,000 N	2,000 N	4,000 N	6,000 N
Heavy duty profiles	1,400 Nm	1,400 Nm	1,400 Nm	1,400 Nm

Minimising dynamic bending moments is crucial, as calculating forces in a moving system can be complex. Vibrations and oscillations may generate forces exceeding approved or calculated limits.

When columns approach their outward endstop with excessive bending moments, “stick and slip” may occur. This phenomenon results from the interaction between sliding and static friction between the sliders and aluminium profiles within the lifting column, caused by excessive bending moments and lack of downward force. The result is undesirable short start/stop movements during operation.

If dynamic bending is applied to a LC3 column, we recommend final testing and approval by the customer.

The following two graphics provide additional information on when a column is overloaded, underloaded, or ideally loaded. Please review your application setup with this information, to ensure correct column usage.

Underload

When the LC3 is fully extended, retracting it may cause the frictional force in the sliders to exceed the load. This can result in unsteady running of the column (stick and slip).

Overload

The motor is overloaded when exceeding the power consumption limit. This will affect the LC3 lifetime.

LC3 IC standard profile offset load diagram 400-700 mm

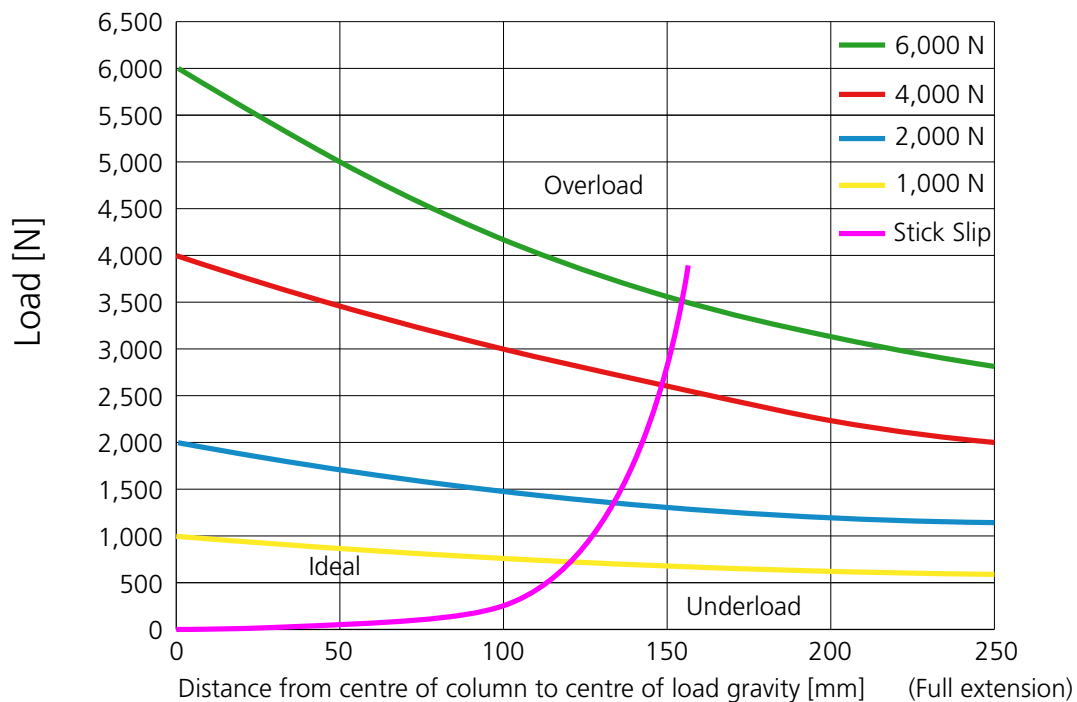

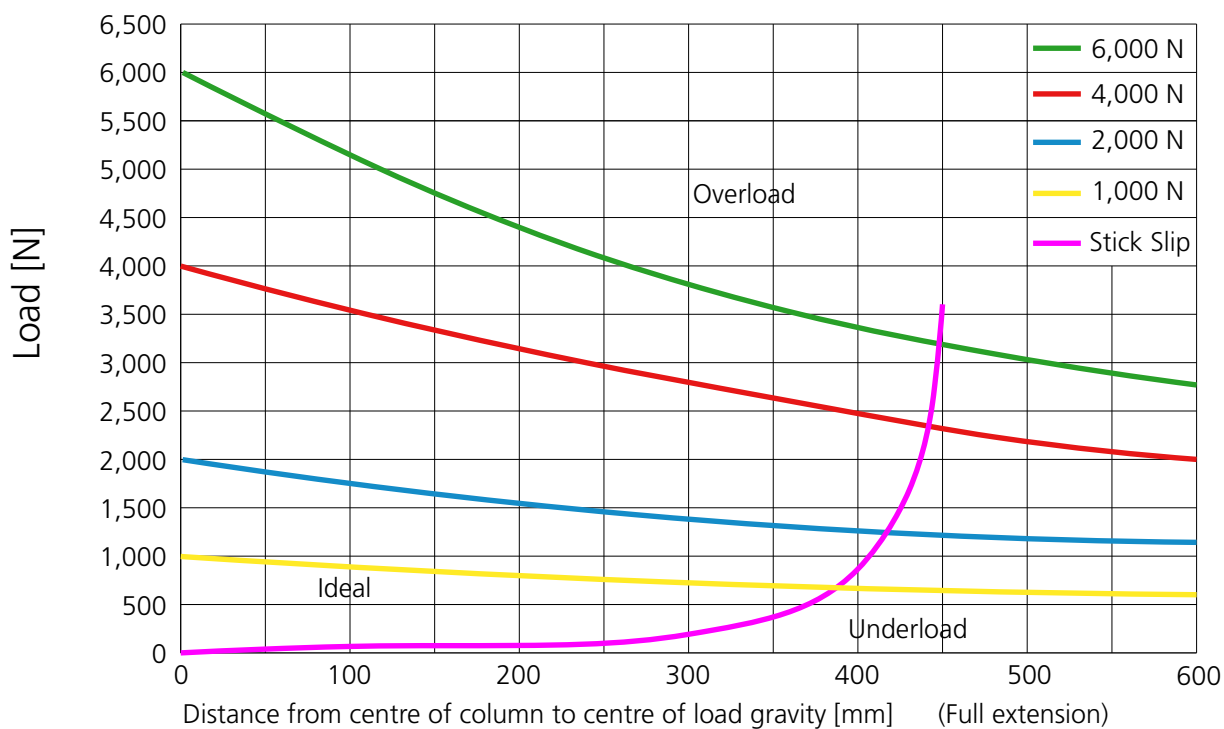

LC3 IC Heavy duty profile offset load diagram 400-700 mm



Parallel

The LC3 IC is designed for both single and multi-use applications, featuring an integrated controller that allows for the parallel operation of up to eight columns simultaneously. For more detailed information on control and feedback options for parallel operation, please refer to the corresponding interface manual available at LINAK.com.

-  To use the parallel functionality, enable Parallel in Actuator Connect and enter the correct number of lifting columns in the system. For more information, please visit LINAK.com.
-  Parallel control functions as a 'critical' system, requiring all lifting columns to be present before allowing movement. It will also halt operation if a malfunction is detected in any lifting column.

LC3 ICs can be set up in rows or arrays for parallel operation. We recommend designing your parallel column setup with a mechanically defined number of lifting columns. Specifically, use two columns for row configurations and three columns for array applications. While it is possible to use more columns, this may result in a mechanically over-defined system, where columns could potentially work against each other due to inherent mechanical tolerances and minor height differences.

Row application

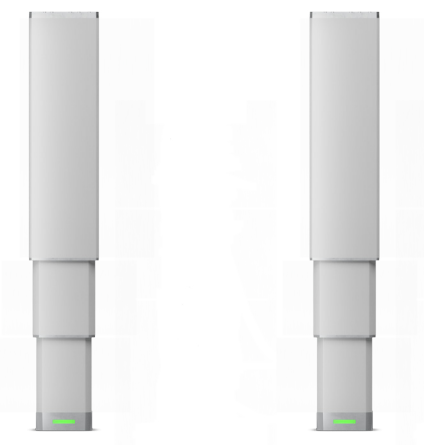

Array application

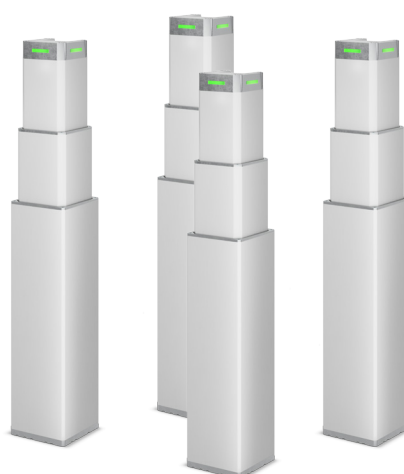

When setting up a parallel system, consider the following key points:

1. **Degrees of Freedom:**
If all columns are locked along all three axes, height tolerances can introduce tensions into the system or the application itself. Excessive tension can cause the system to wedge. To accommodate tolerances and relieve tension, we recommend allowing movement along one or two axes for each lifting column.
2. **Stiffness of the Top Module:**
Tolerances can create tensions within a parallel system. The stiffness of the top module determines whether these tensions are absorbed through bending of the top module or transferred to the LC3 IC. Although the LC3 IC can absorb some tension, it is preferable for the top module to handle these stresses.
3. **Distance Between Columns:**
Placing columns too close together can increase tensions due to minor height differences. We recommend maintaining a minimum distance of 800mm between the centres of columns.



Ensure all columns in a parallel system are perfectly aligned and positioned at the same height. Misalignment can subject individual columns to excessive forces, reducing their lifetime.

The center of gravity of the top module affects the load distribution among the columns. Ensure no column exceeds its nominal load capacity. For top modules with a shifting center of gravity, such as pallets, include a safety buffer in your calculations to account for uneven load distribution. As a rule of thumb, do not calculate with 100% of a column's nominal load in a parallel setup. Instead, use 80% of the nominal load for four columns and 60% for more than six columns.



If an overload occurs, the lifting columns will be stopped and blocked in that direction until an activation in the opposite direction has been made or the system has been re-powered.

Accessories

LC3 IC comes with different accessories to simplify the integration of the column.

-Please note that the accessory needs to be separately ordered.

Service cable for Actuator Connect

Article number: 0367996

Enhance your lifting column experience with the intuitive PC tool Actuator Connect.

- The cable works with all interfaces.

Cable set - 5 meter Flying leads

Article number: 1002W8194

The set includes a 5 m power cable and a 5 m signal cable with 9 wires. The power cable comes with flying leads and the signal cable comes with a molex mini-fit 12-pin connector. This cable works with all interfaces.



Info: The internal bending radius of the cables must be bigger than 3 times the outer dimension of the cable. For instance, if the outer cable dimension is Ø7, the internal radius of the maximum cable bending is 21 mm.



You need an additional ethernet cable with RJ45 connectors for all ethernet interfaces.

Description	Quantity
Power cable, 5 m, 6-pin minifit (CAB0367046-5000)	1
Signal cable, 5 m, 9-pin microfit (CAB0368543-5000)	1
Cable lock with mounting screw T15	1

IO-Link cable set

Article number: 1002W8193

The set includes a 5m power cable and a signal cable for IO-Link with a M12 connector. This set is an alternative if flying leads are not desired.

Description	Quantity
Power cable; 5 m, 6-pin minifit (CAB0367046-5000)	1
IO-link M12 cable; 0.6 m, 9-pin microfit (CAB0367299)	1
Cable lock with mounting screw T15	1

Modbus RTU cable set

Article number: 1002W8197

The set includes a 5m power cable and a signal cable for Modbus RTU with a M12 connector. This set is an alternative if flying leads are not desired.

Description	Quantity
Power cable; 5 m, 6-pin minifit (CAB0367046-5000)	1
RS485 M12 cable; 0.6 m, 9-pin microfit CAB0965633-1000	1
Cable lock with mounting screw T15	1

Mounting plate with top screws

Article number: [1002W8195](#)

Drawings can be downloaded from LINAK.com.

Description	Quantity
Base plate	1
Top screw M10 x 80 A2 ISO 10642	4

Mounting plate with bottom screws

Article number: [1002W8196](#)

Drawings can be downloaded from LINAK.com.

Description	Quantity
Base plate	1
Bottom screw M10 x 45 A2 ISO 10642	4

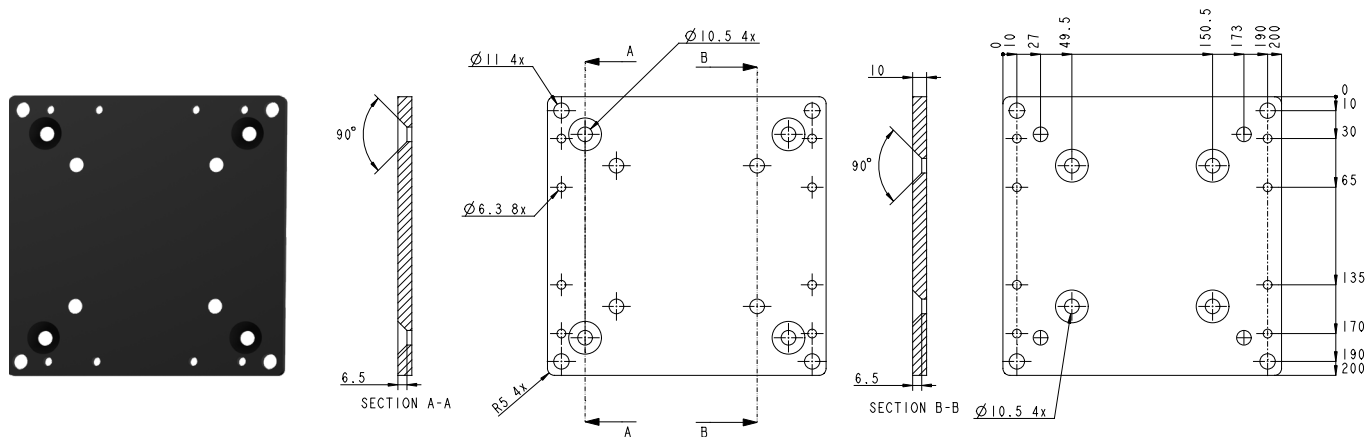

Electrical installation

The default soft stop on the column will send a short peak of higher voltage back towards the power supply. It is important when selecting the power supply that it does not turn off the output, when this backwards load dump occurs.



The power supply should not be able to supply more than 700 Watt to 1,000 N columns. A power supply above 700 Watt has a negative effect on the lifetime of the column if the column runs several times into the mechanical endstop.



The top and the bottom of the column are **not** interconnected with a ground cable.

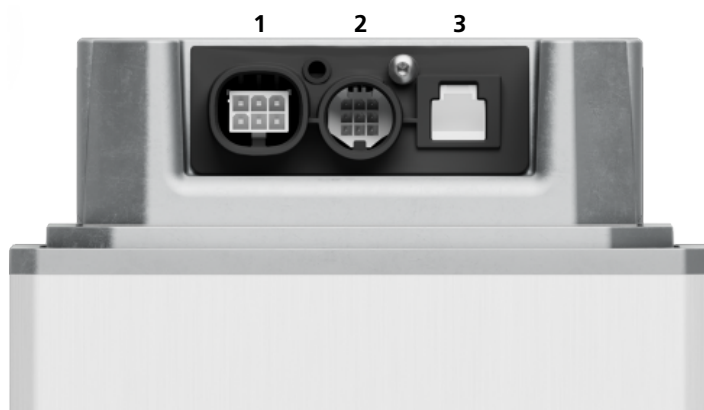

Depending on the chosen option, there can be three different connectors on the LC3 IC Lifting Column:

1. **Power Connector:** The 6-pin connector is for the power supply. It uses a CAB0367046-xxxx cable and is present in both the "F600" and "F700" options
2. **Signal Connector:** The 9-pin signal connector is used for controlling the LC3 IC, obtaining position information, and supplying power to the communication controller. It requires a CAB0368543-XXXX cable, which should be connected to the application's PLC. This connector is also available in both the "F600" and "F700" options
3. **Ethernet Connector:** The RJ-45 connector is used for the Ethernet communication. You can use a shielded (STP) Cat 6 Ethernet cable or a cable suitable for the required transmission speed. This Ethernet connector is only available in the "F700" option, and the cable is not supplied by LINAK

For detailed information on pin configurations and I/O specifications, please refer to the Interface User Manuals available at LINAK.com.

When connecting the power and signal cables to the lifting column, use the cable lock to secure them. Tighten the screw with a Torx Bit T15 screwdriver to 1.6 Nm.

The signal connector provides access to Actuator Connect™. Additional information can be found in the interface manuals at LINAK.com.

Maintenance

- The actuator must be cleaned at regular intervals to remove dust and dirt and inspected for mechanical damages or wear.
- Inspect attachment points, wires, cabinet, and plug, as well as check that the actuator functions correctly.
- To ensure that the pre-greased inner *profiles* remains lubricated, the actuator must only be washed down when *it* is fully retracted.
- The actuator is a closed unit and therefore requires no internal maintenance.

Repair

See warranty disclaimer.

Main groups of disposal

LINAK products may be disposed of, possibly by dividing them into different waste groups for recycling or combustion.

We recommend that our product is disassembled as much as possible at the disposal and that you try to recycle it.

Product	Metal scrap	Cable scrap	Electronic scrap	Plastic recycling or combustion
LC3 IC	X	X	X	X

Warranty

There is an 18 months' warranty on TECHLINE® products against manufacturing faults calculated from the production date of the individual products (see label). Warranty provided by LINAK is only valid so far as the equipment has been used and maintained correctly and has not been tampered with. Furthermore, the actuator must not be exposed to violent treatment. In the event of this, the warranty will be ineffective/invalid. For further details, please see standard terms of sale and delivery for LINAK A/S.

Note

Only an authorised LINAK service centre should repair LINAK actuator systems. Systems to be repaired under warranty must be sent to an authorised LINAK service centre.

In order to avoid the risk of malfunction, all actuator repairs must only be carried out by an authorised LINAK Service shop or repairer, as special tools and parts must be used.

If a system is opened by unauthorised personnel there is a risk that it may malfunction at a later date.

The actuator is not to be opened by unauthorised personnel. In case the actuator is opened, the warranty will be invalid.



DECLARATION OF CONFORMITY

LINAK A/S
Smedevænget 8
DK - 6430 Nordborg

Hereby declares that LINAK Lifting Column:

LC3*****3**_***

(The * in the product description can either be a character or a number, thereby defining the variation of the product)

complies with the EMC Directive 2014/30/EU according to following standards:

EN 55016-2-3:2017+A1+A2, EN 55016-2-1:2014+A1
EN 61000-4-2:2009, EN IEC 61000-4-3:2020, EN 61000-4-4:2012
EN 61000-4-5:2014+A1, EN 61000-4-6:2014, EN 61000-4-8:2010

complies with RoHS2 Directive 2011/65/EU according to the standard:

EN IEC 63000:2018

Additional information:

The product does comply with selected parts of the standards:

EN 61000-6-2:2019, Electromagnetic compatibility (EMC) – Part 6-2: Generic standards – Immunity for industrial environments

EN 61000-6-4:2019: Electromagnetic compatibility (EMC) – Part 6-4: Generic standards – Emission standard for industrial environments

DK-6430 Nordborg, 2024-05-31

LINAK A/S

John Kling, B.Sc.E.E.

Regulatory Affairs Manager

Authorized to compile the relevant technical documentation

This declaration of conformity is issued under the sole responsibility of the manufacturer.

Original Declaration

DECLARATION OF INCORPORATION OF PARTLY COMPLETED MACHINERY

LINAK A/S
Smedevænget 8
DK - 6430 Nordborg

LINAK A/S hereby declares that LINAK DESKLINE® products, characterised by the following models and types:

Control Boxes	CBD6S
Linear Actuators	DB5, DB6, DB14, LA23, LA31
Lifting Columns	DL1A, DL2, DL4S, DL5, DL6, DL8, DL9, DL10, DL11, DL12, DL14, DL15, DL16, DL17, DL18, DL19, DL20, DL21, BASE1, LC1
Desk Panels	DPA, DPB, DPH, DPF, DPG, DPT, DP, DP1CS, DPI
Wireless Controls	BP10
Accessories	BA001, BLE2LIN, CHUSB, DESK Sensor, DF2, Kick & Click, SLS, SMPS, USB2LIN, WiFi2LIN, DC Connector, RFRL

LINAK A/S hereby declares that LINAK HOMELINE® products, characterised by the following models and types:

Control Boxes	CBD6DC
Linear Actuators	LA10, LA18, LA40 HOMELINE
Dual Actuators	TD4, TD5
Controls	BP10, HC10, HC20, HC40
Accessories	BA002, CP, BLE2DC, BLE2LIN, LED Light Rail, MD1, SMPS, WiFi2LIN

LINAK A/S hereby declares that LINAK MEDLINE® & CARELINE® products, characterised by the following models and types:

Control Boxes	CA10, CA20, CA30, CA40, CA63, CAL40, CB6, CB6S, CB6P2, CB8, CB9, CBJ2, CBJ Care, CBJ Home, CO41, CO53, CO61, CO65, CO71, COL50, OPS, PJ2, PJB4
Linear Actuators	LA20, LA23, LA24, LA27, LA28, LA29, LA30, LA31, LA34, LA40, LA44
Lifting Columns	BL1, LC1, LC3
Controls	ABL, ACC, ACK, ACO, ACOM, ACL, DP, DPH, FS, FS3, FPP, HB30, HB70, HB80, HB100, HB190, HB200, HB400, HD80, HL70, HL400
Accessories	BA16, BA18, BA19, BA22, BAJ, BAJL, BAL40, BAL50, CH01, CHJ2, CHL40, CHL50, DJB, LIN2OB, MJB2, MJB5 Plus, Massage Motor, PJB4, QLCI2, SLS, SMPS10, UBL, UBL2, UBL4 Motion, USB-A Power Adapter

LINAK A/S hereby declares that LINAK TECHLINE® products, characterised by the following models and types:

Linear Actuators	LA12, LA14, LA23, LA25, LA30, LA33, LA35, LA36, LA37, LA76, LA77
Lifting Columns	LC3 IC
Accessories	FMB

comply with the following parts of the Machinery Directive 2006/42/EC, ANNEX I, Essential health and safety requirements relating to the design and construction of machinery: 1.5.1 Electricity supply

The relevant technical documentation is compiled in accordance with part B of Annex VII and this documentation or part hereof will be transmitted by post or electronically to a reasoned request by the national authorities.

This partly completed machinery must not be put into service until the final machinery into which it is to be incorporated has been declared in conformity with the provisions of the Machinery Directive 2006/42/EC where appropriate.

Nordborg, 2024-07-10



LINAK A/S

John Kling, B.Sc.E.E., Certification and Regulatory Affairs
Authorised to compile the relevant technical documentation

Original declaration

Contacts

FACTORIES

Denmark - Headquarters
LINAK A/S
Phone: +45 73 15 15 15
Fax: +45 74 45 80 48
Fax (Sales): +45 73 15 16 13
Web: www.linak.com

China
LINAK (Shenzhen) Actuator Systems, Ltd.
Phone: +86 755 8610 6656
Phone: +86 755 8610 6990
Web: www.linak.cn

Slovakia
LINAK Slovakia s.r.o.
Phone: +421 51 7563 444
Web: www.linak.sk

Thailand
LINAK APAC Ltd.
Phone: +66 33 265 400
Web: www.linak.com

USA
LINAK U.S. Inc.
Americas Headquarters
Phone: +1 502 253 5595
Fax: +1 502 253 5596
Web: www.linak-us.com
www.linak-latinamerica.com

SUBSIDIARIES

Australia
LINAK Australia Pty. Ltd
Phone: +61 3 8796 9777
Fax: +61 3 8796 9778
E-mail: sales@linak.com.au
Web: www.linak.com.au

Austria
LINAK Zweigniederlassung - Österreich (Wien)
Phone: +43 (1) 890 7446
Fax: +43 (1) 890 744615
E-mail: info@linak.de
Web: www.linak.at - www.linak.hu

Belgium
LINAK Actuator-Systems NV/SA
(Belgium & Luxembourg)
Phone: +32 (0)9 230 01 09
E-mail: beinfo@linak.be
Web: www.linak.be - www.fr.linak.be

Brazil
LINAK Do Brasil Comércio De Atuadores Ltda.
Phone: +55 (11) 2832 7070
Fax: +55 (11) 2832 7060
E-mail: info@linak.com.br
Web: www.linak.com.br

Canada
LINAK Canada Inc.
Phone: +1 502 253 5595
Fax: +1 416 255 7720
E-mail: info@linak.ca
Web: www.linak-us.com

Czech Republic
LINAK C&S s.r.o.
Phone: +42 058 174 1814
Fax: +42 058 170 2452
E-mail: info@linak.cz
Web: www.linak.cz - www.linak.sk

Denmark - International
LINAK International
Phone: +45 73 15 15 15
E-mail: info@linak.com
Web: www.linak.com

Denmark - Sales
LINAK Danmark A/S
Phone: +45 86 80 36 11
Fax: +45 86 82 90 51
E-mail: linak@linak-silkeborg.dk
Web: www.linak.dk

Finland
LINAK OY
Phone: +358 10 841 8700
E-mail: linak@linak.fi
Web: www.linak.fi

France
LINAK France E.U.R.L
Phone: +33 (0) 2 41 36 34 34
Fax: +33 (0) 2 41 36 35 00
E-mail: linak@linak.fr
Web: www.linak.fr

Germany
LINAK GmbH
Phone: +49 6043 9655 0
Fax: +49 6043 9655 60
E-mail: info@linak.de
Web: www.linak.de

India
LINAK A/S India Liaison Office
Phone: +91 120 4531797
Fax: +91 120 4786428
E-mail: info@linak.in
Web: www.linak.in

Ireland
LINAK UK Limited (Ireland)
Phone: +44 (0)121 544 2211
Fax: +44 (0)121 544 2552
+44 (0)796 855 1606 (UK Mobile)
+35 387 634 6554 (Rep.of Ireland Mobile)
E-mail: sales@linak.co.uk
Web: www.linak.co.uk

Italy
LINAK ITALIA S.r.l.
Phone: +39 02 48 46 33 66
Fax: +39 02 48 46 82 52
E-mail: info@linak.it
Web: www.linak.it

Japan
LINAK K.K.
Phone: 81-45-533-0802
Fax: 81-45-533-0803
E-mail: linak@linak.jp
Web: www.linak.jp

Malaysia
LINAK Actuators Sdn. Bhd.
Phone: +60 4 210 6500
Fax: +60 4 226 8901
E-mail: info@linak-asia.com
Web: www.linak.my

Netherlands
LINAK Actuator-Systems B.V.
Phone: +31 76 5 42 44 40 /
+31 76 200 11 10
E-mail: info@linak.nl
Web: www.linak.nl

New Zealand
LINAK New Zealand Ltd
Phone: +64 9580 2071
Fax: +64 9580 2072
E-mail: nzsales@linak.com.au
Web: www.linak.com.au

Norway
LINAK Norge AS
Phone: +47 32 82 90 90
E-mail: info@linak.no
Web: www.linak.no

Poland
LINAK Polska
LINAK Danmark A/S (Spółka Akcyjna)
Phone: +48 22 295 09 70 /
+48 22 295 09 71
E-mail: info@linak.pl
Web: www.linak.pl

Republic of Korea
LINAK Korea Ltd.
Phone: +82 2 6231 1515
Fax: +82 2 6231 1516
E-mail: info@linak.kr
Web: www.linak.kr

Slovakia
LINAK Slovakia S.R.O.
Phone: +421 51 7563 444
Web: www.linak.sk

Spain
LINAK Actuadores, S.L.u
Phone: +34 93 588 27 77
Fax: +34 93 588 27 85
E-mail: esma@linak.es
Web: www.linak.es

Sweden
LINAK Scandinavia AB
Phone: +46 8 732 20 00
Fax: +46 8 732 20 50
E-mail: info@linak.se
Web: www.linak.se

Switzerland
LINAK AG
Phone: +41 43 388 31 88
E-mail: info@linak.ch
Web: www.linak.ch - www.fr.linak.ch
www.it.linak.ch

Taiwan
LINAK (Shenzhen) Actuator systems Ltd.
Taiwan Representative office
Phone: +886 2 272 90068
Fax: +886 2 272 90096
E-mail: sales@linak.com.tw
Web: www.linak.com.tw

Turkey
LINAK İth. İhr. San. ve Tic. A.Ş.
Phone: +90 312 4726338
Fax: +90 312 4726635
E-mail: info@linak.com.tr
Web: www.linak.com.tr

United Kingdom
LINAK UK Limited
Phone: +44 (0)121 544 2211
Fax: +44 (0)121 544 2552
E-mail: sales@linak.co.uk
Web: www.linak.co.uk

DISTRIBUTORS

Argentina
Novotec Argentina SRL
Phone: 011-4303-8989 / 8900
Fax: 011-4032-0184
E-mail: info@novotecargentina.com
Web: www.novotecargentina.com

Colombia
MEM Ltda
Phone: +[57] (1) 334-7666
Fax: +[57] (1) 282-1684
E-mail: servicioalcliente@memltda.com.co
Web: www.mem.net.co

India
Mechatronics Control Equipments India Pvt Ltd
Phone: +91-44-28558484, 85
E-mail: bala@mechatronicscontrol.com
Web: www.mechatronicscontrol.com

Indonesia
PT. Himalaya Everest Jaya
Phone: +6 221 544 8956 /+6 221 544 8965
Fax: +6 221 619 1925
Fax (Sales): +6 221 619 4658
E-mail: hejplastic-div@centrin.net.id
Web: www.hej.co.id

Israel
NetivTech LTD
Phone: +972 55-2266-535
Fax: +972 2-9900-560
Email: info@NetivTech.com
Web: www.netivtech.com

Singapore
Servo Dynamics Pte Ltd
Phone: +65 6844 0288
Fax: +65 6844 0070
E-mail: servodynamics@servo.com.sg

South Africa
Industrial Specialised Applications CC
Phone: +27 011 466 0346
E-mail: gartht@isagroup.co.za
Web: www.isaza.co.za

United Arab Emirates
Mechatronics
Phone: +971 4 267 4311
Fax: +971 4 267 4312
E-mail: mechtron@emirates.net.ae