



SAE J1939 CAN bus Version 3.1 User manual v1.3

Version 3 applies to all standard CAN bus actuators produced
the 19th of August 2019 and onwards

Contents

Preface	4
LINAK® application policy	5
Revision overview	6
About LINAK® CAN bus actuators	7
Summary	7
Functional overview	8
Command details	10
Run in/out	10
Position	10
Maximum current in/out	10
Speed control	10
Status feedback details	11
Status feedback details	12
Position feedback	12
Current feedback	12
Soft start/stop	12
CAN bus specifications	13
Standards	13
Internal monitoring	14
Current limits and measurements	14
Voltage	15
Temperature	15
H-bridge	15
Parameters	15
Recovery mode	16
Sleep mode	17
Environmental data and tests	18
Operational environment	18
Supply voltage	18
Power loss	18
Over voltage	18
EMC	19
BusLink service interface	20
Installing LINAK® CAN bus actuators	21
Introduction	21
Connections	21
Electrical installation	22

Manual run mode.....	23
CAN hardware addressing	23
Proprietary input state	25
Proprietary A	27
Data field	27
Proprietary B	28
Diagnostics overview.....	31
Diagnostic Troubleshoot Codes (DTC).....	33
Diagnostics examples	34
Network Management	35
Diagnostics	35
Usecases.....	36
Example 1:	36
Example 2:	37
Example 3:	38
Example 4:	39

Preface

Dear User,

We are delighted that you have chosen a product from LINAK®.

LINAK systems are high-tech products based on many years of experience in the manufacture and development of actuators, electric control boxes, controls, and chargers.

This user manual does not address the end-user, but is intended as a source of information for the manufacturer of the equipment or system only, and it will tell you how to install, use and maintain your LINAK electronics. It is the responsibility of the manufacturer of the end-use product to provide a User Manual where relevant safety information from this manual is passed on to the end-user.

We are confident that your LINAK product/system will give you many years of hassle-free operation. Before our products leave the factory they undergo full function and quality testing. If you should experience any problem with your LINAK product/system please contact your local supplier. LINAK subsidiaries and some distributors have authorised service centres, which are always ready to help you.

LINAK provides warranty on all LINAK products. The warranty, however, is subject to correct use in accordance with the specifications, maintenance being done correctly and any repairs being carried out at a service centre, which is authorised to repair LINAK products.

Changes in installation and use of LINAK products/systems can affect their operation and durability. The products are not to be opened by unauthorised personnel.

This User Manual has been written based on our present technical knowledge. We are constantly striving to update both our products and the associated information we therefore reserve the right to carry out technical modifications without prior notice.

This user manual refers to the CAN bus software version: SW01050000V3-x

LINAK A/S

LINAK® application policy

The purpose of the application policy is to define areas of responsibilities in relation to applying a LINAK product defined as hardware, software, technical advice, etc. related to an existing or a new customer application.

LINAK products as defined above are applicable for a wide range of applications within Medical, Furniture, Desk, and Industry areas. Yet, LINAK cannot know all the conditions under which LINAK products will be installed, used, and operated, as each individual application is unique.

The suitability and functionality of the LINAK product and its performance under varying conditions (application, vibration, load, humidity, temperature, frequency, etc.) can only be verified by testing, and shall ultimately be the responsibility of the LINAK customer using any LINAK product.

LINAK shall be responsible solely that LINAK products comply with the specifications set out by LINAK and it shall be the responsibility of the LINAK customer to ensure that the specific LINAK product can be used for the application in question.

Revision overview

Version 1.3

Revision overview added to the manual

Changes regarding software version 3.1

In The data field: bit 255 can now be used for 'Soft start' and 'Soft stop' in byte 3 and 4

Terms of use updated

Page 6

Page 27

Page 40

About LINAK® CAN bus actuators



Summary

This document describes the capabilities of LINAK TECHLINE® CAN bus components and the requirements for controlling these. It specifies the technologies involved, the environmental data specification and the functional description.

LINAK TECHLINE CAN bus actuators are primarily designed with focus on mobile agriculture and industrial automation.

The communication protocol relies on the SAE J1939 standard. The contents of this document assume the reader is familiar with the SAE J1939 standard.

In addition to full position control, the CAN bus actuator is able to provide feedback information about the piston position, service data and full diagnostics. It also provides system identification data and actual current at runtime.

Functional overview

The LINAK® TECHLINE® CAN bus offers a command set for controlling the actuator. This is split up into Commands and Configuration Management (Proprietary A), Status (Proprietary B) and diagnostics.

J1939 Proprietary A	Commands and Configuration Management	
	Commands	Run forward/backward/to position/stop
	Setup values	Current limit in/out Soft start/stop time Max. speed
J1939 Proprietary B	Status	
	Running status	Current Position
		Direction End stop reached Over current Input pin levels
	Counters	Number of endstops Number of starts
	Error status	Hall sensor Over voltage Under voltage CAN communication End Stop Signal (ESS) Power on block state Over temperature

Table 1. Command set, configuration management and status feedback.

SAE J1939-73 Diagnostics	Diagnostics	
	Setup	Actuator address CAN bus transmission rate
	Identification	Unique ID number (UIN) Software ID Production order number Production date
	Historic values	Max. current recorded Max./min. temperatures recorded Number of end stops Number of starts
	Usage	Current · time [A · s] Runtime
	Reason for last stop	Over temperature Over/under voltage Over current Communication error

Table 2. Diagnostics setup.

Status feedback details

A number of status parameters can be observed while the actuator is *not* in sleep mode. The status flags are bit masked.

Status flag feedback

Value	Function	Comment
0	End Stop Signal (ESS) in	The actuator has reached the physical or virtual endstop in
1	ESS out	The actuator has reached the physical or virtual endstop out
2	Over current*	The actuator has measured a current larger than permitted for a longer period of time than allowed
3	Running out	Will indicate that the actuator is running outwards
4	Running in	Will indicate that the actuator is running inwards
5	Reserved	Always 1
6	Reserved	Always 1
7	Reserved	Always 1

Table 3. Status flags overview.

* An Overcurrent flag will prevent the actuator from further movement in the same direction. To clear the flag, send a stop command and order the actuator to run in the opposite direction.

Error code* feedback

Value	Function	Comment
0	No error	No error detected
1	Hall error	Hall position sensor or magnet is not responding as expected
2	Over voltage	The actuator has measured a voltage larger than permitted
3	Under voltage	The actuator has measured a voltage lower than permitted while running
4	Failed to Keep CAN signal alive	Failed to maintain <i>CAN keep alive signal</i> . No General Request Message received for 300 milliseconds while in a run condition
5	ESS error	The actuator is experiencing unexpected behaviour
6	Power on Block State	Must be cleared after power up. This will prevent an unintentional movement
7	Temperature error	One of the two temperature sensors report a higher temperature than permitted

Table 4. Error codes overview.

*Error codes must be cleared in order to continue, except Error 6 'Power on Block State' which can also be cleared using the 'Stop' command. Error codes are enumerated, indicating the active error of the highest priority.

Status feedback details

Position feedback

Value	Function	Comment
0 - 64255	Position	Position in 1/10 th mm
65024	Position lost	Position discrepancy or actuator is not initialised

Table 5. Position feedback overview.

Current feedback

Value	Function	Comment
0	Not running	Current level is indicating no activity
1 - 250	Current	Measured motor current

Table 6. Current feedback overview.

Soft start/stop

To reduce mechanical stress, a ramp up and ramp down time can be set in both directions.

Hard stop 0 sec
Min. ramp time: 300 ms
Max. ramp time: 30 sec.

A ramp down time between 0 and 300 ms is not allowed in order to minimise the effect of back EMF from the motor.

CAN bus specifications

This section describes the requirements of the CAN bus hardware and software interface.

The physical layer is in accordance with J1939-15.

Speed	125 kbps, 250 kbps, 500 kbps or Auto baud (changeable in BusLink)
Max. bus length	40 metres
Max. stub length	3 metres
Max. node count	10 (30*)
Wiring	Unshielded twisted pair
Cable impedance	120 Ω ($\pm 10\%$)

The maximum cable length delivered by LINAK® is not longer than 3 metres. Consequently, all system tests carried out are limited to consist of 3 meter cables.

Non-error tolerant physical layer with the following specifications: Low-power mode is according to ISO 11898-5.

* The SAE J1939-15 can accept up to 30 nodes. See section 3.1 of J1939-15 May 2014 for details.

Standards

The following standards and revisions are the bases of the LINAK TECHLINE® CAN bus software:

- SAE J1939-21 DEC2010 Data Link Layer
- SAE J1939-31 APR2014 Network Layer
- SAE J1939-71 APR2014 Application Layer
- SAE J1939-73 JUL2013 Application Layer – Diagnostics
DM14 (Memory access request)
DM15 (Memory access response)
DM16 (Binary data transfer)
- SAE J1939-81 JUN 2011 Network Management
- SAE J1939-82 AUG 2008 Compliance - Truck and bus**

** Complies with relevant parts of the SAE J1939-82.

Internal monitoring

A number of parameters are monitored during operation to prevent overloading the electronics and to minimise the risk of mechanical damage.

Current limits and measurements

The principle behind the current measurement is an 'above limit' and 'below limit' accumulating counter. When the Timeout counter reaches a specific value the current cut-off goes into effect. The timeout value is pre-set at 200 to 500ms depending on actuator type.

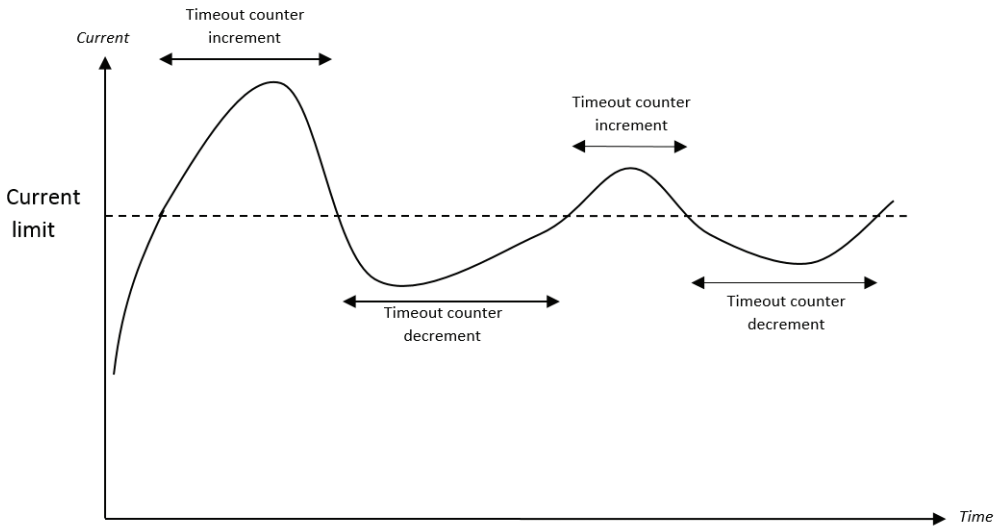

Figure 2. Dynamic current limit principle.

In case of current limit activation (Timeout counter max is reached), the actuator will stop and an over current error is triggered. The error is cleared when the actuator is activated in the opposite direction or by issuing a Clear error command.

Custom over current limit can only be lower than or equal to the fixed factory setting.

Voltage

The supply voltage level is monitored in order to maintain a safe operation and to protect the circuitry.

Temperature

Two temperature monitoring circuits are in place to measure the absolute temperature of the board and the centre temperature of the H-bridge.

H-bridge

The H-bridge conditions are monitored at all times. Several conditions are required in order to run.

Among these are:

- Correct voltage supplies
- Heartbeat safety signal
- Correct temperatures
- No errors

Parameters

In addition to the immediate monitoring, a number of parameters are saved for long-term evaluation.

These include:

- Number of starts in either direction
- Reason for last stop
- Total running time
- Under and over voltage
- Maximum current
- Number of current overloads in either direction

These parameters will help the engineer sort out existing issues. Considering a combination of parameter values, the lifetime load can indicate a potential failure before it happens and thereby prevent downtime.

Recovery mode

The purpose of the Recovery mode is to gain the ability to perform movement even if the actuator is in an internal error state. When running the actuator using Manual run Recovery mode, any of the errors listed below that may be present, will be ignored.

When to engage Recovery mode movement:

- If the actuator has encountered an error, preventing it from moving to a position required to complete the task.
- If the operation detects a misalignment in the actuator. For example, reporting 0 position while not fully retracted.

If it becomes necessary to engage Recovery mode, the user must be aware that the actuator is running in an abnormal condition and the issue should be addressed.

The following states will prevent normal operation but allow Recovery mode operation.

- Hall sensor error
- Over voltage
- Under voltage
- CAN communication error
- End Stop Signal (ESS) switch error
- Power on block state
- Temperature error
- Heartbeat error
- SMPS error

Each time the Recovery mode is used, an internal counter will increment.

The Run to position functionality is not available in Recovery mode.

Sleep mode

The sleep and wakeup functionality is according to ISO11898-5. The current consumption in sleep mode is:

Sleep mode current consumption			
Supply voltage	25 °C	60 °C *	85 °C *
12 V	100 µA	1.0 mA	1.2 mA
24 V	250 µA	2.0 mA	2.4 mA

Table 7. Sleep mode current consumption.

* The current consumption at 60°C - 85°C is subject to change.

Entering sleep mode

The actuator will enter sleep mode after a preset default time of 5 minutes. Conditions for entering sleep mode are one of the following:

- No CAN bus activity
- No Service interface activity
- No manual drive activity

Exiting sleep mode

- Any CAN bus activity
- Service interface activity
- Activating manual run
- Power up

Environmental data and tests

The CAN bus actuators fulfil the environmental requirements as defined:

Operational environment

Ambient temperature: -30°C to 65°C (full performance only from +5°C to 40°C)
Relative humidity: 30% to 80% @ 30°C
Pressure: 700hPa to 1060hPa

Storage environment

Ambient temperature: -55°C to 105°C
Relative humidity: 30% to 80% @ 30°C
Pressure: 700hPa to 1060hPa

Supply voltage

The actuator will be available in two supply voltage ranges, 12 VDC and 24 VDC. The accepted supply voltage range is specified according to ISO16750-2012.

Supply voltage	V _{MIN}	V _{TYP}	V _{MAX}	Reference	Note
12 V	10.5 V	12 V	16 V	ISO 16750-2:2012 - Code D	Motor running
	6 V	12 V	16 V	ISO 16750-2:2012 - Code A	Motor not running CAN communication possible
24 V	18 V	24 V	32 V	ISO 16750-2:2012 - Code H	Motor running
	10 V	24 V	32 V	ISO 16750-2:2012 - Code E	Motor not running CAN communication possible

Table 8. Voltage supply levels.

Power loss

In case of power loss, the actuator position and other important data is saved by the on-board microcontroller.

Over voltage

If the voltage rises above approx. 40 volts, the system will enter overvoltage protection mode and shut down.

EMC

The Electromagnetic Compatibility tests performed on the LINAK® CAN bus actuator comply with the TECHLINE® Electrical Test Specification. The scope of tests is verified and accredited by DELTA A/S test laboratory.

Norm/Standard	Test decription
ISO 16750-2:2012	Supply voltage range
	Overvoltage
	Superimposed alternating voltage
	Slow lowering and raising the voltage supply
	Momentary drop in supply voltage
	Reset behaviour for voltage drop
	Reversed voltage
	Ground reference and supply offset
	Open circuit test
	Short circuit protection
	Load dump – Test pulse 5a
	Load dump test pulse 5b
ISO 7637-2:2011	Test pulse 1
	Test pulse 2a
	Test pulse 2b
	Test pulse 3a
	Test pulse 3b
ISO 16750-2:2012	Test pulse 4
ISO 7637-2:2011	Voltage transient emission test on power supply lines
ISO 7637-3:2007	Electric transient transmission by cap. and inductive coupling
CISPR 25 IEC:2008	Conducted disturbance voltage measurement
	Radiated emission – ALSE method
CISPR 16-1-2:2010	Conducted emission
CISPR 16-2-3:2010	Radiated emission
ISO 10605 2 nd Ed.	ESD immunity
IEC 61000-4-2 2 nd Ed.	ESD immunity
ISO 11452-1:2005, ISO 11452-2:2004, ISO 11452-4:2011, ISO 11452-5:2002	Interference immunity
IEC 61000-4-3:2006	Interference fields immunity test
IEC 61000-4-8:2010	Power frequency magnetic field
IEC 61000-4-4:2004	Burst transients
IEC 61000-4-5:2006	Surge transients

Table 9. LINAK TECHLINE EMC test overview.

BusLink service interface

The BusLink service interface offers a wide range of settings and status feedback options. Use the LINAK® USB2LIN cable and the LINAK BusLink PC software will gain access to:

BusLink settings

- Initialisation
- Current limit settings
- Soft start/stop timing

BusLink feedback

- Run time parameters
- Number of starts and stops
- Maximum current and temperature
- Error messages

The actuator can also be run manually using BusLink control interface. During normal CAN operation, BusLink manual run is disabled. The service interface is only intended to run with the BusLink PC software tool.



Figure 2. LINAK USB2LIN service cable.



Figure 3. LINAK adapter cable.

See the [BusLink Quick Guide](#) for details on how to connect to the specific actuator model.

The USB2LIN service cable and adapter cable suitable for LA33CAN, LA36CAN and LA37CAN can be ordered as PN: 0367997.

The LA14CAN and LA25CAN USB2LIN service and adapter cable can be ordered as PN: 0147997

Installing LINAK® CAN bus actuators

Introduction

This section will assist you in the installation of the LINAK CAN bus actuator. Going through parameters and procedures necessary for a successful implementation.

- Connections
- Electrical installation
- Communication
- See usecases here: "Usecases" on page 36

Connections

The tables below define the wire connections to the LINAK TECHLINE® CAN bus actuators. These colours are consistent with all LINAK TECHLINE CAN bus actuators.

Single connector actuators

Power connector, 8-pin mini-fit connector

LINAK cable	Description
Brown	+ Power supply (12/24VDC)
Blue	- Power supply (GND)
Black	Manual run in / Input 1
Red	Manual run out / Input 2
White	Service interface GND / Input 3
Purple	Service interface DATA
Yellow	CAN H
Green	CAN L

Table 10. Power and communication wire colour.

Dual connector actuators

Power connector, 6-pin mini-fit connector

LINAK cable	Description
Brown	+ Power supply (12/24VDC)
Blue	- Power supply (GND)

Table 11. Power wire colours.

Communication connector, 6-pin micro-fit connector

LINAK cable	Description
Black	Manual run in / Input 1
Red	Manual run out / Input 2
White	Service interface GND / Input 3
Purple	Service interface
Yellow	CAN H
Green	CAN L

Table 12. Communication wire colours.

By default, cables are supplied with flying leads.

Electrical installation

The J1939-15 defines the Reduced Physical Layer, 250K bits/sec, Un-Shielded Twisted Pair (UTP) and runs with separate communication and power supply wires.

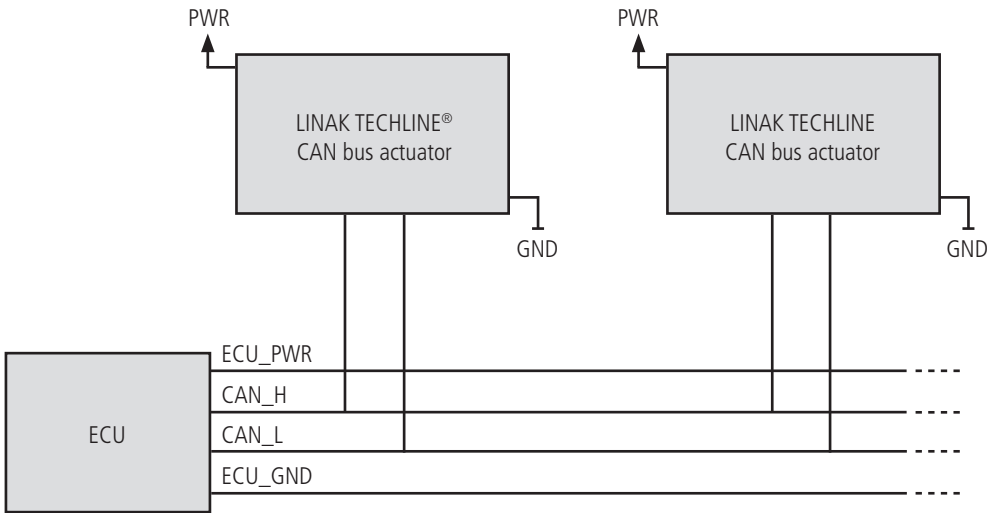

Figure 4. Power supply connection setup.

The power supply for the LINAK® CAN bus actuator should be kept separate from the CAN bus power supply, if such one exists.

Manual run mode

If manual run mode is engaged, the Service interface is enabled.

During manual run mode where Inputs 1 - 3 are low or floating on power-up, the actuator will continue to send status feedback on the CAN bus. However, if other CAN devices are active on the network, manual run mode will be disengaged. The CAN software address range 128-247 is reserved for this mode. The Service interface is also accessible during manual run mode.

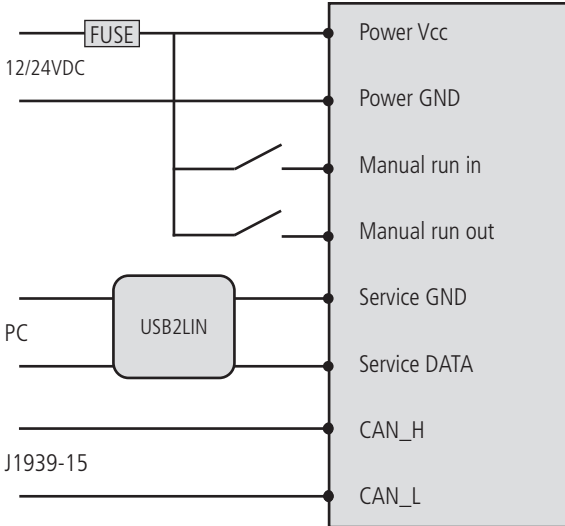

Figure 5. Manual run connection diagram.

CAN hardware addressing

If hardware addressing was selected during ordering, a maximum of 7 unique addresses can be configured. Manual run mode is no longer possible. See table 13 for details.

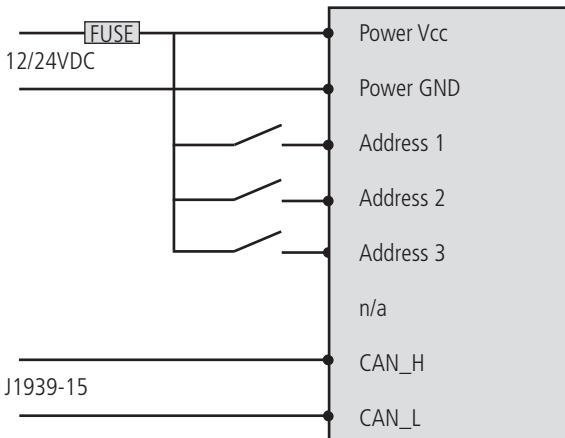

Figure 6. Address mode connection diagram using Power Vcc.

If the actuator is in hardware addressing mode the following addresses are configured using the 3 input pins.

Address configuration and pin settings.

Pin setting			Address
Address pin 1 Black	Address pin 2 red	Address pin 3 white	
Open	Open	Open	Manual Run Mode
High	High	High	0x80 (128)
High	High	Open	0x81 (129)
High	Open	High	0x82 (130)
High	Open	Open	0x83 (131)
Open	High	High	0x84 (132)
Open	High	Open	0x85 (133)
Open	Open	High	0x86 (134)

Table 13. Pin address settings.

The address configuration consists of input pins which can be pulled high or left as open circuit. Address colors indicate standard LINAK® wire colors.

Proprietary input state

The hardware input state can be read in the Proprietary B general status frame. Byte 7, bit 0 to bit 5 provides status on the three physical inputs. Two bits per input pin:

Bits	Address pin
0 and 1	1
2 and 3	2
4 and 5	3
6 and 7	n/a

Table 14. Address bit relation

Input bits		Definition
0	0	0 - 25% Vcc
0	1	25 - 50% Vcc
1	0	50 - 75% Vcc
1	1	75 - 100% Vcc

Table 15. Pin address levels

Termination

Termination resistors of 120 Ω shall be connected according to the figure below. The actuator does not have internal termination.

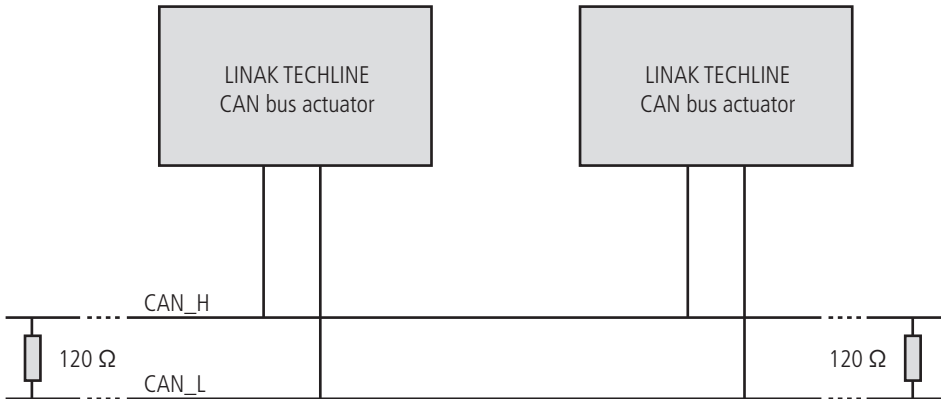

Figure 8. Terminal resistor configuration.

Communication

The installation must be performed by qualified personnel with knowledge of CAN bus communication and the SAE J1939 standard. Only the sections of the standard which are relevant for the installation will be discussed.

- SAE J1939-21 Data Link Layer Proprietary A, Proprietary B
- SAE J1939-73 Application Layer Diagnostics
- SAE J1939-81 Network Management

Data range definition

Range name	1 byte	2 bytes
Valid signal	0 - 250 0x00 - 0xFA	0 - 64255 0x0000 - 0xFAFF
Parameter specific indicator	251 0xFB	64256 - 64511 0xFB00 - 0xFBFF
Reserved range for future indicator bits	252 - 253 0xFC - 0xFD	64512 - 65023 0xFC00 - 0xFDFF
Error indicator	254 0xFE	65024 - 65279 0xFE00 - 0xFEFF
Not available, not installed or not requested	255 0xFF	65280 - 65535 0xFF00 - 0xFFFF

Table 16. SAE J1939 defined data ranges

Communication

Proprietary A

Function: General request

Description: Write to proprietary A to clear error state, run out, run in or run to a specific position in addition to setting speed and current limit.

Min. transmission rate: 250ms

PGN: 0x00EF00

Data field

Byte7 (Sent last)	Byte6	Byte5	Byte4	Byte3	Byte2	Byte1	Byte0 (Sent first)
Reserved, write 0xFF	Reserved, write 0xFF	Soft Stop [ms*50]	Soft Start [ms*50]	Speed [%*0.5]	Current [mA*250]	Position [mm*0.1] MSB	Position LSB

Table 17. 8 bytes containing all changeable data.

Byte(s)	Name	Details		Slot
Byte6 - Byte7	Reserved	Always write 0xFF		Not applicable
Byte5	Soft Stop	0-250 251, 255 252-254	Stop ramping time (ms) Actuator default value Reserved.**	50 ms/bit
Byte4	Soft Start	0-250 251, 255 252-254	Start ramping time (ms) Actuator default value Reserved.**	50 ms/bit
Byte3	Speed	0-199 200-250 251 252-255	Speed to use (0.5%/bit: 0%-99.5%) Use 100% speed Actuator default value Reserved.**	(0% - 100%)
Byte2	Current	0-250 251 252-255	Maximum current to use Actuator default value Reserved.**	Slot 410: SAEec09 (0.25 A/bit: 0.0A - 62.5A)
Byte0- Byte1	Position	0-64255 64256 64257 64258 64259 64260-65535	Run to position Clear ErrorCode register Command run to actuator out Command run to actuator in Command stop actuator* Reserved.**	Slot 283: SAEmd01 (0.1 mm/bit: 0mm - 6.43m)

Table 18. Data field definition

* This command is mandatory after power-up and communication time-out (5s).

** In Software version 3.0: bit 255 in byte 4 and 5 were reserved.

*** Do not run, regardless of other bytes in request.

Communication

Proprietary B

Function: General status
Description: Read status parameters, motor current and actuator piston position.
Min. transmission rate: 100ms
PGN: 0x00FF00, 65280d

Data field

Byte7 (Sent last)	Byte6	Byte5	Byte4	Byte3	Byte2	Byte1	Byte0 (Sent first)
External InputState	Speed [mm*0, 1/s] MSB	Speed LSB	ErrorCode: 8-bit error code	StatusFlags: Bit-field	Current [mA *250]	Position [mm*0.1] MSB	Position LSB

Table 19. Bytes (8) containing all status information.

Communication

Byte(s)	Name	Details	Slot
Byte7	InputState	b0,1 = Input 1 level (25% of VCC / bit) b2,3 = Input 2 level b4,5 = Input 3 level	Not defined
Byte6 [4-7]	Reserved	Always reads 0xF_	Not applicable
Byte5-Byte6 [0-3]	Speed	Speed feedback 0-4015 Speed of actuator piston (0.1mm/s / bit) 4016-4095 Reserved	Not defined
Byte4	ErrorCode	8-bit error code indicating the currently active error of highest priority 0 = No error 1 = Hall error 2 = Over voltage 3 = Under voltage 4 = Failed to maintain CAN keep alive signal 5 = ESS error 6 = Power on block state 7 = Temperature error 8 = Heart beat error (internal) 9 = SMPS error (internal)	Not defined
Byte3	StatusFlags	8 independent status bit-indicators b0 = ESS in b1 = ESS out b2 = Overcurrent b3 = Running out b4 = Running in b5 = Reserved b6 = Reserved b7 = Reserved	Not defined
Byte2	Current	Measured motor current 0 Not running 1-250 Measured motor current 251-253 Reserved 254 Fault in current measurement circuit 255 Reserved	Slot 410: AEec09 (0.25 A/ bit: 0.25A - 62.5A)
Byte0-Byte1	Position	Position feedback 0-64255 Position of actuator piston 64256-65023 Reserved 65024 Position lost 65025-65535 Reserved	Slot 14: SAEds04 (0.1 mm/ bit: 0mm - 6.43m)

Table 20. Data field definition

Application Layer – Diagnostics

The following Diagnostics Messages are used in the retrieval of diagnostics data according to SAEJ1939-73 section 5.7.14.1.2.

DM14 Memory access request
DM15 Memory access response
DM16 Binary data transfer

Pointer type: 1 = Directed spatial addressing (parameter IDX)
Pointer extension: 0 = SPM space

Return codes

The status return code for any diagnostics function indicating an error or warning.

0x01 = OK
0x80 = Invalid parameter index
0x81 = Invalid action code
0x82 = Write access denied
0x83 = Value underflow
0x84 = Value overflow
0x85 = Invalid enumerator value

Table 21. Status return codes

Diagnostics overview

Pointer/IDX		Data size	Description	Slot Id	Slot name	Access	Example	Meaning
dec	hex		Setup values					
516096	0x07E000	U8	Current limit out [mA*250]	410	SAEec09	R	60	15 A
516097	0x07E001	U8	Current limit in [mA*250]	410	SAEec09	R	24	6 A
516098	0x07E002	U16	Soft start time out [ms]	132	SAEtm02	R	1500	1.5 s
516099	0x07E003	U16	Soft start time in [ms]	132	SAEtm02	R	500	500 ms
516100	0x07E004	U16	Soft stop time out [ms]	132	SAEtm02	R	2000	2 s
516101	0x07E005	U16	Soft stop time in [ms]	132	SAEtm02	R	300	300 ms
516102	0x07E006	U8	Maximum speed [%*0.5]	299	SAEpc18	R	180	90 %
516103	0x07E007	U16	Virtual ESS out position [mm * 0.1]	14	SAEds04	R	2000	200 mm
516104	0x07E008	U16	Virtual ESS in position [mm * 0.1]	14	SAEds04	R	50	5 mm
516105	0x07E009	U8	Actuator address	35	SAEsa01	R	123	123

Table 22.

Pointer/IDX		Data size	Description	Slot Id	Slot name	Access	Example	Meaning
dec	hex		Identification					
516107	0x07E00B	U32	UIN	283	SAEmd01	R	12345678	Serial number
516108	0x07E00C	U32	Software identification (SW variant)*	283	SAEmd01	R	SW1234-567V1-	SW variant 1234567 version 1
516109	0x07E00D	U32	Software identification (SW version Major)*	283	SAEmd01	R		
516110	0x07E00E	U32	Software identification (SW version Minor)*	283	SAEmd01	R		
516111	0x07E00F	U32	Production order number*	283	SAEmd01	R		
516112	0x07E010	U32	Production date	283	SAEmd01	R	20150728	July 28th 2015

Table 23.

* (SW variant/build number) [ASCII, text (variable, NULL delimited)]

Pointer/IDX		Data size	Description	Slot Id	Slot name	Access	Example	Meaning
dec	hex		Historic values					
516113	0x07E011	U8	Maximum current seen [mA*250]	410	SAEec09	R	61	15,25 A
516114	0x07E012	U8	Maximum FET temperature seen [°C - 40]	67	SAEtp01	R	138	98° C
516115	0x07E013	U8	Maximum ambient temperature seen [°C - 40]	67	SAEtp01	R	82	42° C
516116	0x07E014	U8	Minimum ambient temperature seen [°C - 40]	67	SAEtp01	R	36	-4° C

Table 24.

			Usage totals					
516117	0x07E015	U32	Current usage [As]	283	SAEmd01	R	21605	Total power consumed: 6Ah
516118	0x07E016	U32	Run-time [s]	64	SAEtm05	R	4321	Total running time: 1h12m1s

Table 25.

			Reason for last stop, stop counters and communication error counter					
516119	0x07E017	U16	Reason for last stop	64	SAEtm05	R	2	Over temperature
516120	0x07E018	U18	Over voltage stops	133	SAEct03	R		
516121	0x07E019	U8	FET over temperature stops	133	SAEct03	R		
516122	0x07E01A	U8	Ambient over temperature stops	133	SAEct03	R		
516123	0x07E01B	U8	Low voltage stops	133	SAEct03	R		
516124	0x07E01C	U8	Hall error stops	133	SAEct03	R		
516125	0x07E01D	U8	ESS switch error stops	133	SAEct03	R		
516126	0x07E01E	U8	LINAK current overloads out stops	133	SAEct03	R		
516127	0x07E01F	U8	LINAK current overload in stops	133	SAEct03	R		
516128	0x07E020	U8	Custom current overloads out stops	133	SAEct03	R		
516129	0x07E021	U8	Custom current overload in stops	133	SAEct03	R		
516130	0x07E022		Communication errors	208	SAEct05	R		

Table 26.

Pointer/IDX		Data size	Description	Slot Id	Slot name	Access	Example	Meaning
dec	hex		Historic values					
516131	0x07E023	U16	Number of ESS in	208	SAEec05	R		
516132	0x07E024	U16	Number of ESS out	208	SAEtp05	R		
516133	0x07E025	U32	Number of starts in	209	SAEec07	R		
516134	0x07E026	U32	Number of starts out	209	SAEec07	R		

Table 27.

Diagnostic Troubleshoot Codes (DTC)

SPN	Name	FMI
0x7e400	Actuator	FMI3 = Voltage above normal or shorted to high
0x7e401	Actuator	FMI4 = Voltage below normal or shorted
0x7e402	Actuator	FMI6 = Current above normal or shorted to high
0x7e403	FET Temp	FMI15 = Data valid, but above normal operating range (least significant level)
0x7e404	AMB Temp	FMI15 = Data valid, but above normal operating range (least significant level)

Table 28.

Network Management

Diagnostics

Processes and messages are associated according to SAEJ1939-81 Section 4.2.1.1.

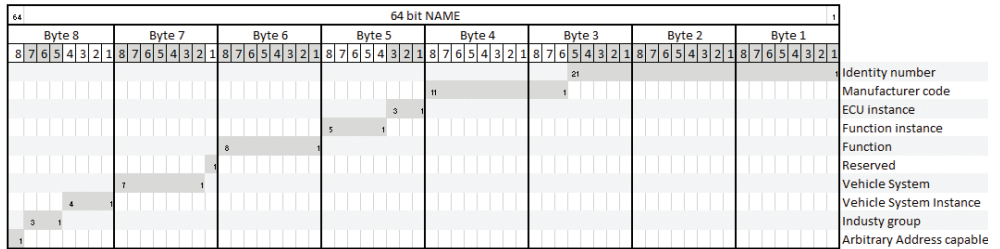

Figure 11. Addresses for the Network Management parameters

- The serial number contained in the Identity number is a unique ID assigned to each actuator.
- ECU instance can be utilised if two or more ECU's are present on the network.
- Function instance is suitable when two or more actuators are present on the same network where the actuators only differ on e.g. Left and Right.

Parameter Name	Size in Bits	Start Byte	Start Bit	Details
Identity Number	21	1	1	Lower 21 bits of UIN (Unique Serial Number)
Manufacturer Code	11	3	6	690 (LINAK® A/S)
ECU Instance	3	5	1	Default 0
Function Instance	5	5	4	Determined by address strapping, Section 2.1.14.3 (2.3.3)
Function	8	6	1	Default 132 (Utility Machine Control)
Reserved	1	7	1	Always 0
Vehicle System	7	7	2	Default 24 (Utility Vehicles)
Vehicle System Instance	4	8	1	Configurable from 0-15
Industry Group	3	8	5	Default 2 (Agriculture and Forestry Equipment)
Arbitrary Address Capable	1	8	8	Always 1: Capable of selecting source address

Table 29. Explanations for the Network Management parameters

Usecases

Example 1:

0 to 100mm Run to Position on a 200mm Actuator.

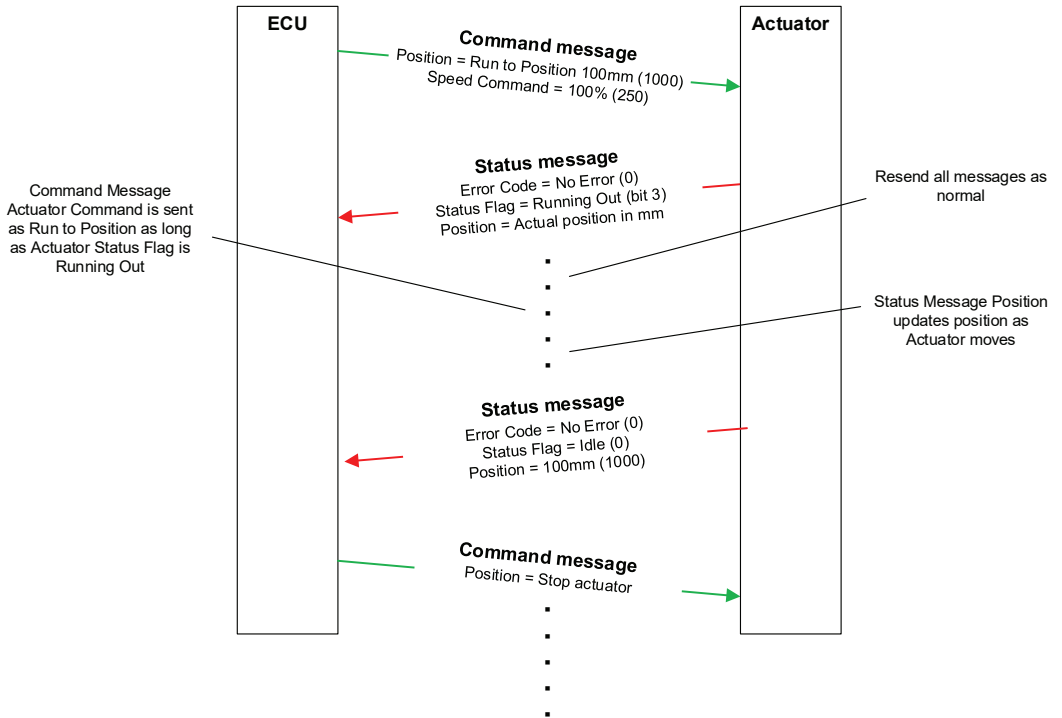

Example 3:

0 to 100mm Run to Position on a 200mm actuator which reaches an Over Current Limit

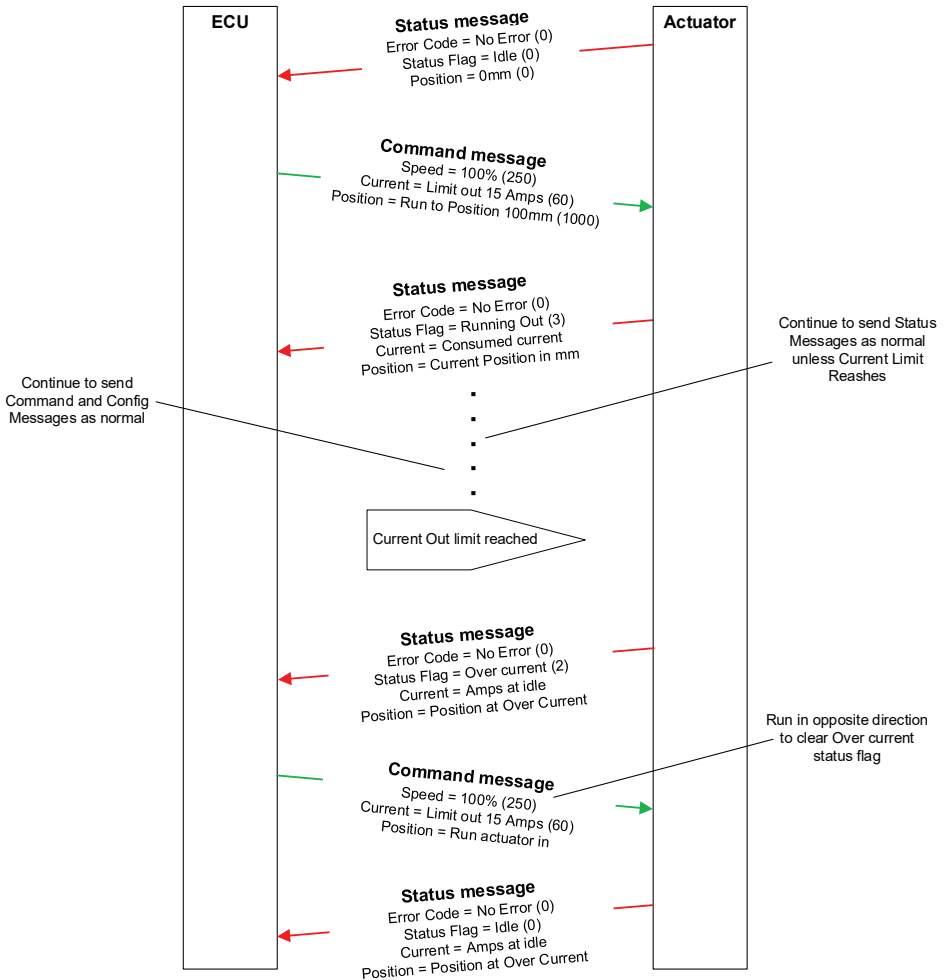

Example 4:

150 to 50mm Run to Position on a 200mm Actuator error caused by under voltage

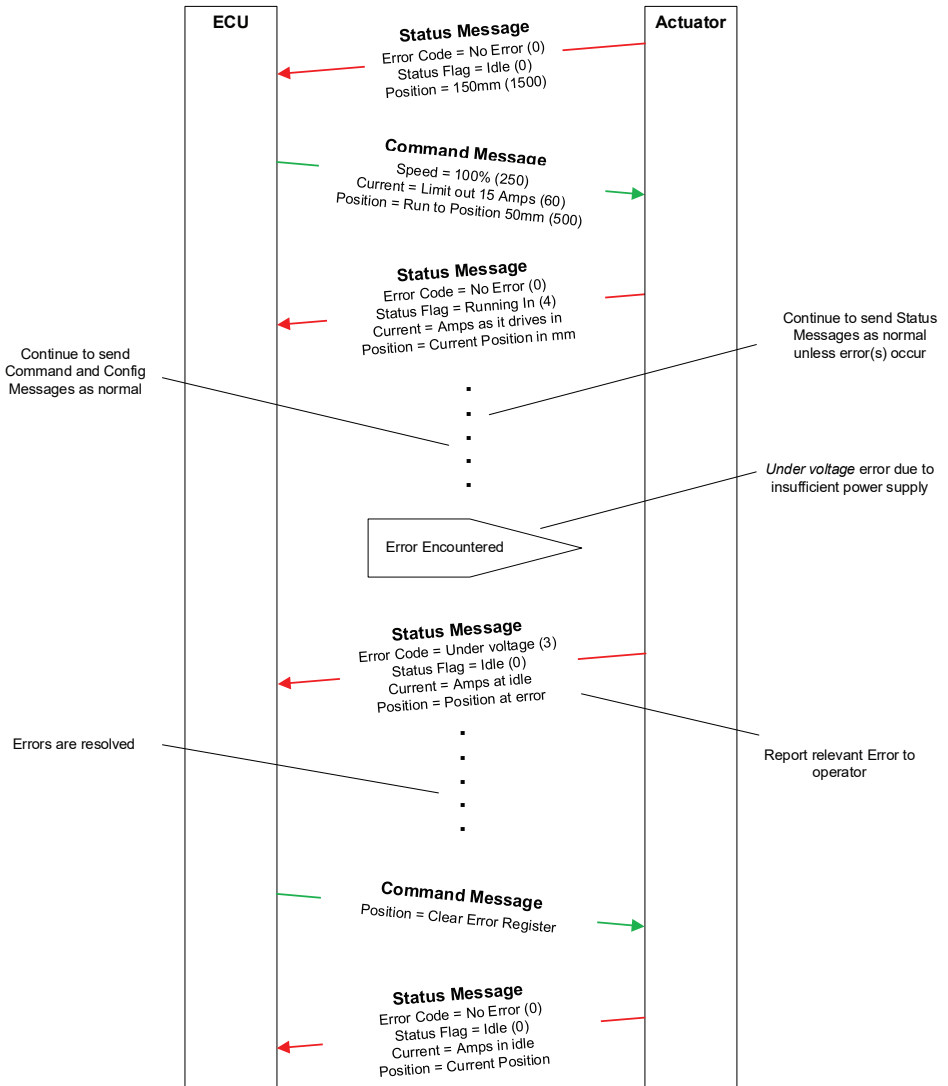

FACTORIES

China

LINAK (Shenzhen) Actuator Systems, Ltd.
Phone: +86 755 8610 6656
Phone: +86 755 8610 6990
www.linak.cn

Denmark - Headquarters

LINAK A/S
Phone: +45 73 15 15 15
Fax: +45 74 45 80 48
Fax (Sales): +45 73 15 16 13
www.linak.com

Slovakia

LINAK Slovakia s.r.o.
Phone: +421 51 7563 444
www.linak.sk

Thailand

LINAK APAC Ltd.
Phone: +66 33 265 400
www.linak.com

USA

LINAK U.S. Inc.
Americas Headquarters
Phone: +1 502 253 5595
Fax: +1 502 253 5596
www.linak-us.com
www.linak-latinamerica.com

SUBSIDIARIES

Australia

LINAK Australia Pty. Ltd
Phone: +61 3 8796 9777
Fax: +61 3 8796 9778
www.linak.com.au

Austria

LINAK Repräsentanz - Österreich (Wien)
Phone: +43 (1) 890 7446
Fax: +43 (1) 890 744615
www.linak.at - www.linak.hu

Belgium

LINAK Actuator-Systems NV/SA
(Belgium & Luxembourg)
Phone: +32 (0)9 230 01 09
www.linak.be - www.fr.linak.be

Brazil

LINAK Do Brasil Comércio De Atuadores Ltda.
Phone: +55 (11) 2832 7070
Fax: +55 (11) 2832 7060
www.linak.com.br

Canada

LINAK Canada Inc.
Phone: +1 502 253 5595
Fax: +1 416 255 7720
www.linak-us.com

Czech Republic

LINAK C&S s.r.o.
Phone: +42 058 174 1814
Fax: +42 058 170 2452
www.linak.cz - www.linak.sk

Denmark - International

LINAK - International
Phone: +45 73 15 15 15
www.linak.com

Denmark - Sales

LINAK DANMARK A/S
Phone: +45 86 80 36 11
Fax: +45 86 82 90 51
www.linak.dk

Finland

LINAK OY
Phone: +358 10 841 8700
www.linak.fi

France

LINAK FRANCE E.U.R.L.
Phone: +33 (0) 2 41 36 34 34
Fax: +33 (0) 2 41 36 35 00
www.linak.fr

Germany

LINAK GmbH
Phone: +49 6043 9655 0
Fax: +49 6043 9655 60
www.linak.de

India

LINAK A/S India Liaison Office
Phone: +91 120 4531797
Fax: +91 120 4786428
www.linak.in

Ireland

LINAK UK Limited (Ireland)
Phone: +44 (0)121 544 2211
Fax: +44 (0)121 544 2552
+44 (0)796 855 1606 (UK Mobile)
+35 387 634 6554
(Republic of Ireland Mobile)
www.linak.co.uk

Italy

LINAK ITALIA S.r.l.
Phone: +39 02 48 46 33 66
Fax: +39 02 48 46 82 52
www.linak.it

Japan

LINAK K.K.
Phone: 81-45-533-0802
Fax: 81-45-533-0803
www.linak.jp

Malaysia

LINAK Actuators Sdn. Bhd.
Phone: +60 4 210 6500
Fax: +60 4 226 8901
www.linak.my

Netherlands

LINAK Actuator-Systems B.V.
Phone: +31 76 5 42 44 40
www.linak.nl

New Zealand

LINAK New Zealand Ltd
Phone: +64 9580 2071
Fax: +64 9580 2072
www.linak.com.au

Norway

LINAK Norge AS
Phone: +47 32 82 90 90
www.linak.no

Poland

LINAK Polska
LINAK Danmark A/S (Spółka Akcyjna)
Phone: +48 22 295 09 70 /
+48 22 295 09 71
www.linak.pl

Republic of Korea

LINAK Korea Ltd.
Phone: +82 2 6231 1515
Fax: +82 2 6231 1516
www.linak.kr

Russia

LINAK LLC
Phone: +7 495 780 3161
Fax: +7 495 687 1426
www.linak.ru

Spain

LINAK Actuadores, S.L.U
Phone: +34 93 588 27 77
Fax: +34 93 588 27 85
www.linak.es

Sweden

LINAK Scandinavia AB
Phone: +46 8 732 20 00
Fax: +46 8 732 20 50
www.linak.se

Switzerland

LINAK AG
Phone: +41 43 388 31 88
Fax: +41 43 388 31 87
www.linak.ch - www.fr.linak.ch
www.it.linak.ch

Taiwan

LINAK (Shenzhen) Actuator systems Ltd.
Taiwan Representative office
Phone: +886 2 272 90068
Fax: +886 2 272 90096
www.linak.tw

Turkey

LINAK İth. İhr. San. ve Tic. A.Ş.
Phone: +90 312 4726338
Fax: +90 312 4726635
www.linak.com.tr

United Kingdom

LINAK UK Limited
Phone: +44 (0)121 544 2211
Fax: +44 (0)121 544 2552
www.linak.co.uk

DISTRIBUTORS

Argentina

NOVOTEC ARGENTINA SRL
Phone: 011-4303-8989/8900
Fax: 011-4032-0184
www.novotecargentina.com

Colombia

MEM Ltda
Phone: +[57] (1) 334-7666
Fax: +[57] (1) 282-1684
www.mem.net.co

India

Mechatronics Control Equipments
India Pvt Ltd
Phone: +91-44-28558484, 85
www.mechatronicscontrol.com

Indonesia

PT. HIMALAYA EVEREST JAYA
Phone: +6 221 544 8956,
+6 221 544 8965
Fax: +6 221 619 1925
Fax (Sales): +6 221 619 4658
www.hej.co.id

Iraq

Scan Medical Tech
Phone: +964 770 470 2202

Israel

NetivTech LTD
Phone: +972 55-2266-535
Fax: +972 2-9900-560
www.netivtech.com

Kingdom of Bahrain

Mechatronics Industrial Equipments
Phone: +973 17280059
Fax: +973 17910045
www.mechatronicsbh.com

Qatar

Mechatronics Industrial Equipments
Phone: +974 44581155
Fax: +974 44689135
www.mechatronicsqatar.com

Russia

OOO FAM
Phone: +7 812 3319333
Fax: +7 812 3271454
www.fam-drive.ru

Singapore

Servo Dynamics Pte Ltd
Phone: +65 6844 0288
Fax (Sales): +65 6844 0070

South Africa

Industrial Specialised Applications CC
Phone: +27 011 466 0346
www.isaza.co.za

United Arab Emirates

Mechatronics Industrial Equipments LLC
Phone: +971 4 267 4311
Fax: +971 4 267 4312
www.mechatronics.ae

LINAK® accepts no responsibility for possible errors or inaccuracies in catalogues, brochures, and other material. LINAK reserves the right to change its products without prior notice. LINAK cannot guarantee product availability and reserves the right to discontinue the sale of any product. The user is responsible for determining the suitability of LINAK products for a specific application. All sales are subject to the 'Standard Terms of Sale and Delivery', available on LINAK websites.

LINAK and the LINAK logotype are registered trademarks of LINAK A/S. All rights reserved.



WE IMPROVE YOUR LIFE